

Department of Mechanical Engineering  
University of Canterbury

**Methodology and Modelling Approach for Strategic  
Sustainability Analysis of Complex Energy-Environment  
Systems**

Submitted in partial fulfilment of the requirements for the Degree of  
Ph.D. in Mechanical Engineering  
in the University of Canterbury by Andreas Hamm

University of Canterbury

2007

©Andreas Hamm

To the People of Rotuma

## **Abstract**

It is likely that in the near future, energy engineering will be required to help society adapt to permanently constrained fuel supplies, constrained green house gas emissions, and electricity supply systems running with minimal capacity margins. The goal of this research is to develop an analytical approach for adaptive energy systems engineering within the context of resource and environmental constraints. This involves assessing available energy resources, environmental and social issues, and economic activities. The approach is applied to a relatively simple case study on Rotuma, an isolated Pacific Island society. The case study is based on new data from field work. A spectrum of development options is identified for Rotuma and a reference energy demand is calculated for each representative level. A spectrum of conceptual reference energy system models is generated for each energy service level with a range of renewable energy penetration. The outcome is a matrix of energy system investment and resource utilization for the range of energy service levels. These models are then used for comparative risk assessment. The result is an easily understood visual based investment and risk assessment for both development and adaptation to constrained resource availability. The results show a clear development opportunity space for Rotuma where needs and services are in balance with investment, local resource availability and environmental constraints.

## Acknowledgements

Many people have been a part of my graduate education, as friends, teachers, and colleagues. My supervisor, Dr. Susan Krumdieck, first and foremost, has been all of these. The foundation for this work comes from her insightful ideas and her gift of thinking beyond the boundaries of the currently accepted. I was also fortunate to have Dr. Mark Jermy as my co-supervisor. He provided invaluable assistance and acute analytical thinking that was instrumental in forming this work into a coherent research document. Thanks to Dr. Andre Dantas of the Department of Civil Engineering, and Dr.-Ing. Markus Spinnler of the Technical University of Munich, Germany, who were always available for help and scientific advice. Systems expert Dr. Leif Isaksen provided me with perceptive input during several meetings and discussions.

Dr. Alan Howard and Dr. Ian Rensel of the University of Hawaii generously contributed an extensive wealth of knowledge, especially regarding Rotuman culture and shared anthropological data. Additional guidance regarding anthropological and Pacific Island themes came from Dr. Karen Nero and Dr. Keith Morrison. Peter Johnston and Herbert Wade, two experts on renewable energy for Pacific Islands, provided helpful advice for setting up the field project.

Dr. Andrew Sturman of the Department of Geography kindly invited us to make use of his team's cutting edge wind modeling capabilities. Mr. Mike Green spent many hours of his time processing wind data from Rotuma and generating constructive wind maps for my use.

Special thanks is also directed towards the technicians of our electrical and mechanical laboratories, in particular Julian Phillips, Julian Murphy, Ron Tinker, Paul Wells, and Graeme Harris. All were indispensable during preparation for field work for Rotuma under an immense time pressure.

Rupeni Mario of the South Pacific Geosciences Commission (SOPAC) in Fiji was active at facilitating organizational and logistical aspects of the field work in Fiji. Rupeni Mario, a native Rotuman, acted as my principal contact with the outer world during my stay on the island. Gerhard Ziehroth, also of SOPAC provided additional assistance. Additional cultural advice on Rotuma came from Monifa Fiu from the WWF, Fiji. I had an exceptionally inspiring exchange of experiences and ideas on various energy issues in the Pacific with Kerry Dunnovan of the Pacific Blue Foundation.

Thanks to the High Council of Chiefs of Rotuma for permitting me to conduct field work on the beautiful paradise island of Rotuma.

Mr. John Bennett generously provided his support of the project on the island in various ways: he not only provided accommodation and transport, but also shared his vast knowledge about Rotuman culture, gave technical assistance and facilitated contacts time and time again.

Fereti Fonmoa and Makrao Takasiawas were my main supports in the field, and Henry Ensasio, Maria Fortea, and Pennemino were always ready to help out.



Tomasi Jones, a returning expat electrical engineer assisted with surveys and generator measurements in the field.

During my stay with Mrs. Isapeti Inia, she never failed to cheer me up. Isapeti Inia studied the Rotuman culture throughout her entire lifetime, and was instrumental in some stages of Rotuma's development in the last fifty years.

As a disclaimer, there are a large number of people from Rotuma who contributed in various ways to the success of this study, who's names are not listed above. For example, on the 40 hrs return trip from Rotuma to Fiji, the captain of the Cagi Ma Ba offered me his cabin when he found me crawling on the steel floor, covered in a mixture of rust, saltwater and old paint heavily sea sick (in fact more sick than I ever remember having been!).

In my office, room 308 of the mechanical engineering wing, I was surrounded by knowledgeable and friendly office mates who helped me daily. Most notably, my office mates, Benoit, Asdis, Jake, Shannon and Hadley have been a great source of practical information, as well as supporting me socially.

I would like to acknowledge my dear family, Mama, Papa, Elisabeth, Christian, and Johannes for there continued support and also my girlfriend Meagan McLeod for her patience and encouragement.

Financial support came from the University of Canterbury by means of a doctoral scholarship. The Rotuma field work was funded by the Pacific Island trust with additional assistance from SOPAC.

# Contents

<b>1</b>	<b>Introduction</b>	<b>15</b>
1.1	Motivation . . . . .	15
1.2	Defining the Problem . . . . .	15
1.3	Thesis Organization . . . . .	16
<b>2</b>	<b>Background</b>	<b>17</b>
2.1	Energy Engineering . . . . .	17
2.1.1	Developments in Energy Engineering . . . . .	17
2.1.2	Remote Systems . . . . .	19
2.2	Modelling Approaches . . . . .	25
2.2.1	MARKAL . . . . .	26
2.2.2	Deeco . . . . .	26
2.2.3	LEAP . . . . .	27
2.2.4	ENPEP . . . . .	27
2.2.5	RETSCREEN . . . . .	29
2.2.6	HOMER . . . . .	29
2.2.7	Hybrid2 . . . . .	30
2.2.8	ViPOR . . . . .	31
2.3	Sustainability Concepts . . . . .	32
2.3.1	Approaches and Methods . . . . .	32
2.3.2	Sustainability Tools . . . . .	38
2.4	Imminent Petroleum Shortage . . . . .	39
2.4.1	Petroleum Production Predictions . . . . .	39
2.4.2	Peak Oil Mitigation . . . . .	40
<b>3</b>	<b>Preliminary Theoretical Considerations</b>	<b>41</b>
3.1	Feedback Control Model of Regional Systems . . . . .	41
3.2	Strategic Analysis Method . . . . .	47
<b>4</b>	<b>Introduction to Rotuma Island</b>	<b>54</b>
4.1	Geography of Rotuma . . . . .	54
4.2	Climate . . . . .	57
4.3	Rotuma's people . . . . .	58

4.4	Daily life on the island . . . . .	59
4.5	Education . . . . .	60
4.6	Economic activities . . . . .	60
4.7	Living Situation . . . . .	67
4.8	Transportation System . . . . .	69
	4.8.1 Transport to the Island . . . . .	69
	4.8.2 Transport on the island . . . . .	70
4.9	Judicature . . . . .	71
4.10	Health . . . . .	71
<b>5</b>	<b>Rotuma Energy Survey</b>	<b>72</b>
5.1	Survey Methodology . . . . .	72
	5.1.1 Domestic Energy Surveys Methodology . . . . .	72
	5.1.2 Other Energy Surveys Methodology . . . . .	76
	5.1.3 Aspirations Survey Methodology . . . . .	77
5.2	Domestic Village Energy . . . . .	79
	5.2.1 Description of Villages . . . . .	80
	5.2.2 Electricity Systems . . . . .	84
	5.2.3 Electricity Use . . . . .	92
	5.2.4 Electricity Economics . . . . .	95
	5.2.5 Aspirations Survey . . . . .	98
5.3	Government Institutions . . . . .	99
	5.3.1 Malhaha Primary and High School . . . . .	99
	5.3.2 Rotuma Water Supply . . . . .	104
	5.3.3 Hospital . . . . .	110
	5.3.4 Additional Surveys . . . . .	113
5.4	Energy Flows . . . . .	113
<b>6</b>	<b>Rotuma Energy Resources</b>	<b>116</b>
6.1	Copra Resources . . . . .	116
	6.1.1 Avenues of Coconut Oil Production . . . . .	117
	6.1.2 Coconut Resource . . . . .	118
6.2	Wind Resources . . . . .	120
	6.2.1 Global wind patterns and wind data . . . . .	120
	6.2.2 Global Wind Maps . . . . .	121
	6.2.3 Rotuma Weather Station Data . . . . .	122
	6.2.4 Wind data Collection on Rotuma . . . . .	126
	6.2.5 Modelling the Wind Resource . . . . .	127
6.3	Solar Resources . . . . .	132

<b>7</b>	<b>Rotuma Case Study</b>	<b>135</b>
7.1	Reference Built Environments . . . . .	135
7.1.1	Level A - Back to Tradition . . . . .	136
7.1.2	Level B - Present Service Level . . . . .	137
7.1.3	Level C - Intermediate Service Level . . . . .	138
7.1.4	Level D - Western Energy Service Level . . . . .	139
7.2	Reference Energy Demands . . . . .	141
7.2.1	Level B . . . . .	141
7.2.2	Level C . . . . .	142
7.2.3	Level D . . . . .	147
7.2.4	Electricity Loads Summary . . . . .	152
7.3	Energy Supply Options . . . . .	153
7.4	Energy Modelling Methodology . . . . .	154
7.5	Modelling Parameters . . . . .	155
7.5.1	Electricity Grid . . . . .	155
7.5.2	Diesel Generator Sets . . . . .	156
7.5.3	Generator fuels . . . . .	157
7.5.4	Photovoltaic Systems . . . . .	159
7.5.5	Wind Turbines . . . . .	159
7.5.6	Power converters . . . . .	160
7.5.7	Battery Systems . . . . .	160
7.5.8	Pumped Storage . . . . .	160
7.6	Risk Assessment Methodology . . . . .	161
7.6.1	General Feasibility . . . . .	162
7.6.2	Resource Security . . . . .	163
7.6.3	Environmental Damage . . . . .	164
7.6.4	Cultural Dilution . . . . .	164
7.7	Individual Risk Assessment Criteria . . . . .	165
7.7.1	Concept Independent Risks . . . . .	165
7.7.2	Concept Level Risks . . . . .	166
7.7.3	Economic Viability . . . . .	169
7.8	Risk Analysis Case Example . . . . .	171
7.9	Risk Results of Concept Independent Risks . . . . .	175
7.9.1	Level A . . . . .	175
7.9.2	Level B . . . . .	175
7.9.3	Level C . . . . .	176
7.9.4	Level D . . . . .	176
7.10	Modelling and Risk Results of B-Level Systems . . . . .	177
7.10.1	Fossil Fuel Supply . . . . .	178
7.10.2	Coconut Oil Supply . . . . .	180
7.10.3	Wind Supply . . . . .	182
7.10.4	Wind-Diesel Hybrid supply . . . . .	184
7.10.5	Solar PV supply . . . . .	186

7.10.6	Solar PV-Diesel Hybrid supply . . . . .	188
7.11	Modelling and Risk Results of C-Level Systems . . . . .	190
7.11.1	Fossil Fuel Supply . . . . .	191
7.11.2	Coconut Oil Supply . . . . .	193
7.11.3	Wind Power . . . . .	195
7.11.4	Wind Diesel Hybrid System . . . . .	196
7.11.5	Solar PV . . . . .	199
7.11.6	Solar PV-Diesel Hybrid System . . . . .	200
7.12	Modelling and Risk Results of D-Level Systems . . . . .	201
7.12.1	Fossil Fuel Supply . . . . .	202
7.12.2	Coconut Oil Supply . . . . .	203
7.12.3	Wind Power . . . . .	205
7.12.4	Wind-Diesel Hybrid System . . . . .	209
7.12.5	Solar PV . . . . .	212
7.12.6	Solar PV-Diesel Hybrid System . . . . .	213
7.13	Summary of Results . . . . .	214
<b>8</b>	<b>Performance Objective Design Considerations</b>	<b>218</b>
8.1	Decision Making and Design . . . . .	218
8.2	ACP Approach vs. Standard Energy Planning . . . . .	220
<b>9</b>	<b>Conclusions</b>	<b>222</b>
<b>10</b>	<b>Future Work</b>	<b>224</b>
<b>A</b>	<b>Glossary</b>	<b>233</b>
<b>B</b>	<b>List of Acronyms</b>	<b>235</b>

# List of Figures

2.1	Example of Reference Energy System Presentation. (Source: <a href="http://www.iiasa.ac.at/Research/ECS/docs/models.html">www.iiasa.ac.at/Research/ECS/docs/models.html</a> ) . . . . .	18
2.2	Map of Tokelau coral atolls (Source: <a href="http://www.simplemaps.iofm.net">http://www.simplemaps.iofm.net</a> )	21
2.3	Utsira energy supply concept (Source: <a href="http://www.hydro.com">http://www.hydro.com</a> ) . .	23
2.4	Map of Porto Santo Island (Source: <a href="http://ct1end.netpower.pt">http://ct1end.netpower.pt</a> ) .	24
2.5	Map of Kiribati Group, South Pacific (Source: <a href="http://www.coral.noaa.gov">http://www.coral.noaa.gov</a> )	25
2.6	Markal - Simplified Flow Chart . . . . .	26
2.7	Deeco - Simplified Flow Chart . . . . .	27
2.8	LEAP - Simplified Flow Chart . . . . .	28
2.9	ENPEP - Simplified Flow Chart . . . . .	28
2.10	RETScreen - Simplified Flow Chart . . . . .	29
2.11	Homer - Simplified Flow Chart . . . . .	30
2.12	Hybrid2 - Simplified Flow Chart . . . . .	31
2.13	ViPOR - Simplified Flow Chart . . . . .	31
3.1	Standard presentation of a feedback control system. Figure taken from (Krumdieck 2007) . . . . .	42
3.2	The regional energy-environment-economy system model according to (Krumdieck 2007). . . . .	43
3.3	Methodology overview. . . . .	47
3.4	From Reference Built Environment to electricity load curves. . . .	49
3.5	Determining the risk of fuel shortages. . . . .	50
3.6	Modelling Fuel Supplies, after (Hirsch et al. 2005) . . . . .	51
3.7	Risk through Environmental Damage. . . . .	52
4.1	Polynesia . . . . .	55
4.2	Topographical Map of Rotuma. Courtesy of the Fiji Lands and Survey Department. . . . .	56
4.3	Mean average monthly temperatures (1936–2000), and lowest and highest recorded temperatures (1971–2000). Recorded at Rotuma weather station (ID W65000) at Ahau. The underlying data was kindly provided by the Fiji Department of Meteorology. . . . .	57

4.4	Average monthly rainfall with lowest and highest recorded monthly rainfall (1912–2000). Recorded at Rotuma weather station (ID W65000) at Ahau. The underlying data was kindly provided by the Fiji Department of Meteorology. . . . .	58
4.5	The seven districts and 32 main villages on Rotuma . . . . .	58
4.6	Rotuma population statistics. . . . .	59
4.7	Community activities on Rotuma. . . . .	61
4.8	Economic activities on Rotuma. . . . .	63
4.9	Business on Rotuma I. . . . .	64
4.10	Kafoa Olsen’s bakery at Malha, possibly the oldest continuous business on Rotuma. . . . .	66
4.11	Businesses on Rotuma II. . . . .	66
4.12	Example for buildings layout of a typical household on Rotuma. Typically, the kitchen building is constructed in (modified) traditional style, with a thatched roof and often corrugated iron walls. The sleeping house is more often made with concrete walls and corrugated iron roofs. Central part of the traditional kitchen is the koua pit, a fireplace for traditional earth cooking. . . . .	68
4.13	Two main means of transport to Rotuma. . . . .	69
5.1	Survey form used for domestic energy surveys on Rotuma. . . . .	75
5.2	Places of domestic energy surveys; Juju, Losa, and Motusa. All other village grids are marked according to their similarity in character to either of the surveyed villages. . . . .	76
5.3	Survey form of aspirations survey. . . . .	78
5.4	Satellite image of Juju and surroundings. Solnohu Island lies within the reef and can be reached by wading through shallow waters at low tide. . . . .	80
5.5	A typical house in Juju village. . . . .	81
5.6	Satellite image of Losa and surroundings. . . . .	82
5.7	Satellite image of Motusa. . . . .	82
5.8	Map of the electricity grid in Juju. . . . .	84
5.9	The Juju village energy system. . . . .	85
5.10	Diesel generator load curve in Juju, recorded on May 10, 2006 . . . . .	85
5.11	Map of the electricity grid in Losa. . . . .	87
5.12	Diesel Generator load curve, recorded on May 28, 2006 . . . . .	87
5.13	Motusa village generator. . . . .	88
5.14	Map of the electricity grid in Motusa. Motusa features the largest village grid on Rotuma. . . . .	89
5.15	Diesel Generator load curve, recorded on June, 8, 2006 . . . . .	89
5.16	Appliance ownership in Juju village. . . . .	93
5.17	Appliance ownership in Losa village. . . . .	93
5.18	Appliance ownership in Motusa. . . . .	93

5.19	Monthly O&M costs for village generator in Juju. . . . .	95
5.20	Distribution of electricity consumption in Motusa for the years 2004 and 2006; also shown is the average normalized electricity price per bin. . . . .	96
5.21	Distribution of electric energy consumption in Motusa. The data is based on monthly kWh readings for two months and three months periods in 2004 and 2006, respectively. . . . .	97
5.22	Results of aspirations survey. The results are based on insufficient data, but give an indication. . . . .	98
5.23	Malhaha High School . . . . .	99
5.24	Malhaha Primary and High Schools . . . . .	100
5.25	Diesel generator of Malhaha High School. . . . .	100
5.26	Locations of deep wells on Rotuma. The water distribution network is shown in bright blue. . . . .	104
5.27	Distribution of water consumption over equally-spaced fractions of population. . . . .	107
5.28	Lepjea pumping station - one of the three deep wells on Rotuma. . . . .	109
5.29	Hospital on Rotuma. . . . .	110
5.30	Hospital on Rotuma. . . . .	110
5.31	Energy use in Rotuma hospital. All values are in kWh per day. . . . .	111
5.32	Energy use in Rotuma hospital. All values are in kWh per day. . . . .	113
5.33	Main energy flows on Rotuma in T.J. For comparison, current rates of copra export are added. Copra energy values reflect the energy content of coconut oil that could be produced from the copra. . . . .	115
6.1	Section through a coconut. . . . .	117
6.2	Traditional coconut oil processing chain, as practiced on Rotuma. . . . .	117
6.3	Commercial coconut oil production processing chain. . . . .	118
6.4	Annual copra production on Rotuma in tons per year. Sources: (Rensel 1993) and (BURGEAP 2006). . . . .	119
6.5	Copra production on Rotuma in 2006. . . . .	120
6.6	The Global Wind Systems (From <a href="http://www.newmediastudio.org">http://www.newmediastudio.org</a> ) . . . . .	121
6.7	Global Wind Map ( <a href="http://www.windatlas.dk/World/Index.htm">http://www.windatlas.dk/World/Index.htm</a> ) . . . . .	122
6.8	Stanford University Global Wind Map (Archer and Jacobson 2005) . . . . .	123
6.9	Position of Rotuma weather Station, . . . . .	124
6.10	Wind frequency rose for Rotuma, based on data from the Met-Service weather station, 2000 to 2006. The axis shows frequency values in %, with values based on 24 angular sectors. . . . .	125
6.11	Seasonal wind profile on Rotuma, based on data from the Met-Service weather station, 2000 to 2006. . . . .	126
6.12	Positions of wind masts during field survey on Rotuma. . . . .	127
6.13	Wind mast installations on Rotuma. . . . .	128
6.14	Sample of wind data recorded on Rotuma. . . . .	129



6.15	Windmap for 10m anemometer height. This wind map is based on data for the period from 19. April through 15. May 2006. This period showed wind values well below annual averages. Contour lines are added for 2 and 3m/s. . . . .	129
6.16	Windmap for 25m anemometer height. This wind map is based on data for all of 2003. . . . .	130
6.17	Windmap for 50m anemometer height. This wind map is based on data for all of 2003. . . . .	130
6.18	Monthly average daily solar irradiation; values are mean values of the years 2000 to 2005 with standard deviations. . . . .	133
6.19	Instruments at the Rotuma weather station. . . . .	134
7.1	Method for determination of generic system load curves. . . . .	141
7.2	Option B; domestic reference load curve of average village of 27 households. . . . .	143
7.3	Option C; system load curve (weekdays). . . . .	147
7.4	Option D; system load curve. . . . .	152
7.5	Overview of key in and outputs of the HOMER model. . . . .	154
7.6	Risk matrix, adapted from (Elms 1998). . . . .	162
7.7	Diesel Generation Scheme . . . . .	178
7.8	Level B: Coconut Generation Scheme . . . . .	180
7.9	Level B: Wind generation scheme. . . . .	182
7.10	Level B: Wind diesel hybrid generation scheme. . . . .	184
7.11	Level B: Solar PV generation scheme. . . . .	186
7.12	Level B: Solar PV Diesel Hybrid generation scheme. . . . .	188
7.13	Level C: Diesel Generation Scheme. . . . .	191
7.14	Level C: Coconut Generation Scheme . . . . .	193
7.15	Level C: Wind generation scheme. . . . .	195
7.16	Level C: Wind diesel hybrid generation scheme. . . . .	196
7.17	Level C: Solar PV generation scheme. . . . .	199
7.18	Level C: Solar PV Diesel Hybrid generation scheme. . . . .	200
7.19	Level D: Diesel Generation Scheme. . . . .	202
7.20	Level D: Coconut Generation Scheme. . . . .	203
7.21	Method for modelling of wind power system with pumped storage. . . . .	205
7.22	Distribution functions of excess wind generation, and unmet electric loads. . . . .	206
7.23	Level D: Wind generation scheme. . . . .	207
7.24	Level D: Wind diesel hybrid generation scheme. . . . .	209
7.25	Level D: Solar PV generation scheme. . . . .	212
7.26	Level D: Solar PV Diesel Hybrid generation scheme. . . . .	213

7.27	System costs shown in the representation of the feasibility space. Shown are domestic energy costs (DEC), i.e. the household's monthly energy bill. Also shown is the normalized cost of energy and the initial investment (I) in millions of dollars. . . . .	214
7.28	Graphic representation of ESI matrix for Rotuma. . . . .	217
8.1	Suggested context of decision making in ACP approach. . . . .	219

# List of Tables

2.1	Generation at Fakaofu . . . . .	21
2.2	Generation in Porto Santo Island . . . . .	24
2.3	Predictions for Peak in Global Oil Production . . . . .	39
5.1	List of items surveyed in Rotuma and described in this chapter. . . . .	73
5.2	Summary data of all village grids on Rotuma. . . . .	91
5.3	Malhaha generator specification . . . . .	101
5.4	Appliance list survey - Malhaha High School . . . . .	102
5.5	Appliance list survey - Malhaha Primary School . . . . .	103
5.6	Characteristics of wells on Rotuma . . . . .	105
5.7	Pumped Water Production Statistics . . . . .	107
5.8	Water Pumps Characteristics . . . . .	109
5.9	Solar system at Rotuma hospital. . . . .	111
5.10	Appliances at the Rotuma Rural Hospital . . . . .	112
6.1	Classes of Wind Power Density at 10m and 50m (Vertical Extrapolation based on 1/7 power law) . . . . .	123
6.2	Measured vs. modeled annual mean wind speeds. . . . .	131
6.3	Monthly average daily sunshine hours at Ahau, Rotuma. . . . .	132
7.1	Option B; load schedule. . . . .	142
7.2	Option B; domestic reference appliance penetration. . . . .	143
7.3	Electricity consumer entities as in service level C. . . . .	144
7.4	Domestic and commercial appliance penetration basis for service level C. . . . .	145
7.5	Level C - government loads. . . . .	145
7.6	Level C; load schedule. . . . .	146
7.7	Domestic and commercial appliance penetration basis for service level D. . . . .	148
7.8	Level D - government loads. . . . .	149
7.9	Level D; load schedule. . . . .	150
7.10	Level D; load schedule - continued . . . . .	151

7.11	Overview table of electrical load characteristics from energy service level B through D. . . . .	152
7.12	The energy supply system options used for analysis. . . . .	153
7.13	Breakdown of electricity grid costs. . . . .	156
7.14	Generator cost parameters. . . . .	157
7.15	Costs of copra processing plants. . . . .	158
7.16	Photovoltaic systems cost parameters . . . . .	159
7.17	Wind turbine systems cost parameters. . . . .	159
7.18	Converter systems cost parameters. . . . .	160
7.19	Pumped storage cost parameters. . . . .	161
7.20	Evaluation criteria for risk assessment - risks common to service level. Likelihoods of occurrence and impacts are listed as “p” and “i”. . . . .	165
7.21	Evaluation criteria for risk assessment - individual system concepts. . . . .	166
7.22	Modelling results - Level B - Diesel . . . . .	178
7.23	Modelling results - Level B - Coconut oil . . . . .	180
7.24	Modelling results - Level B - Wind . . . . .	183
7.25	Modelling results - Level B - Wind Diesel. . . . .	184
7.26	Modelling results - Level B - Solar PV . . . . .	186
7.27	Modelling results - Level B - Solar PV–Diesel hybrid system. . . . .	188
7.28	Modelling results - Level C - Diesel . . . . .	191
7.29	Modelling results - Level C - Coconut oil . . . . .	193
7.30	Modelling results - Level C - Wind . . . . .	195
7.31	Modelling results - Level C - Wind Diesel . . . . .	196
7.32	Modelling results - Level C - Solar PV . . . . .	199
7.33	Modelling results - Level C - Solar PV Diesel. . . . .	200
7.34	Modelling results - Level D - Diesel. . . . .	202
7.35	Modelling results - Level D - Coconut oil. . . . .	203
7.36	Modelling results - Level D - Wind . . . . .	207
7.37	Modelling results - Level D - Wind Diesel . . . . .	209
7.38	Modelling results - Level D - Solar PV . . . . .	212
7.39	Modelling results - Level D - Solar PV Diesel . . . . .	213
7.40	Summary of Risk indices (ACI) . . . . .	215
8.1	Comparison of ACP Method with traditional method. . . . .	221

# Chapter 1

## Introduction

This thesis concerns an approach to energy engineering and infrastructure planning which includes sustainable practice in an integrated and intuitive way. The approach is demonstrated in a detailed study of the current energy system, and future options of a remote Pacific Island community.

### 1.1 Motivation

Current technology and infrastructure have been developed to utilize low cost, abundantly available fossil energy. But world oil production is expected to peak in the near future (e.g. (Deffeyes 2001)) and climate change is only one of many problems contributed to by regional energy systems. The fossil fuel system cannot continue to operate according to its current assumptions of unlimited fossil energy and continuous growth.

Environmental and social problems effected the emergence of a broad range of sustainability research. However sustainability concepts that effectively inform energy engineering are rare. Some existing sustainability concepts are mainly ethics based and hard to translate into engineering requirements, others assume that future technologies will evolve to solve the problems incurred by the use of current technologies. Engineers generally design products to meet requirements within constraints. Impending resource shortages will pose new constraints to regional energy engineering, but to date these constraints have not found their place in the regional energy planning process. While sustainability considerations have influenced energy engineering, sustainability is still evaluated at a component level rather than a systems level.

### 1.2 Defining the Problem

This thesis develops and demonstrates an approach for regional energy systems planning which integrates resource constraints and requirements for long term

sustainability of the society into the established and familiar process of energy planning. This thesis demonstrates a systems approach to energy planning, in which the indefinite viability of a human society is a requirement built into the process from the beginning and not as an option. The approach is tested on a real regional energy system. As a first step the approach is applied to define future options for energy systems supporting a range of energy service levels for a test case. This case is a Pacific Island, Rotuma. Several factors make Rotuma a good case study: its small size and isolation make in and output easy to observe. The current energy system exhibits an easily understood low energy service level with comparatively simple infrastructure. But first and foremost, Rotuma is open to new approaches. This is, in part due to its highly vulnerable position in the petroleum supply chain.

### 1.3 Thesis Organization

A literature review is carried out in Chapter 2 in order to place this work in context. Chapter 3 sets the theoretical frame for this thesis. The meaning of sustainability is defined for this context and coined anthropogenic continuity. Krumdieck's theoretical model of anthropogenic continuity is introduced, and the place of this research is demonstrated and further clarified in the model. The second part of the chapter derives the proposed approach to regional energy planning. The approach is named Anthropogenic Continuity Planning (ACP) approach.

Chapter 4 introduces Rotuma Island, the case study for this thesis. The objective of this chapter is to take the reader for a virtual journey around Rotuma, visiting the most important features: Geography and climate, as well as the people, lifestyle and economy.

Field survey results are presented in Chapters 5 and 6. The focus of Chapter 5 rests on presenting the results of domestic and commercial energy surveys, and surveys of the energy supply and distribution systems on the island. In contrast, the energy resource side is assessed in Chapter 6. Investigated are the solar energy potential, the wind power situation, and coconut production.

The method is implemented in Chapter 7. All steps of the method are covered in depth, and the analysis is presented in detail. The chapter concludes with a summary of risk analysis results and the identification of the opportunity space. The opportunity space is a graphical form of presentation of the set of distinguishable energy system options that represent real development opportunities for Rotuma.

A critical discussion of the case study results in Chapter 8 puts the new Anthropogenic Continuity Planning approach in perspective.

Conclusions are drawn and opportunities for future work are pointed out in Chapters 9 and 10.

# Chapter 2

## Background

This chapter explores developments in the disciplines of energy engineering and sustainability science in order to set the frame for investigations in this thesis. A survey of the field of general energy engineering leads directly to energy sustainability in a broad sense. Particular challenges in a) energy engineering for remote systems and b) energy engineering for Pacific Islands are covered in Section 2.1.2.

Section 2.3 summarizes research activities that are concerned with sustainability. An overview of definitions and its historical development is followed by an outline of conceptual sustainability frameworks and a collection of sustainability metrics and indices.

A discussion of imminent global resource constraints through peak oil completes the chapter.

### 2.1 Energy Engineering

#### 2.1.1 Developments in Energy Engineering

Energy engineering in the original sense refers to the discipline of designing electrical power supply systems to match an existing or forecasted electricity demand. A booming economy after World War II encouraged exponential growth of energy consumption in Western countries. Energy engineering reached a turning point only after the 1973 OPEC oil embargo as the field expanded to include the *demand side* and new technologies to improve *energy efficiency* (Turner 2001), (Weston 1992).

The analysis of both, supply side and demand side together is generally referred to as energy systems engineering.

#### Modelling in Energy Systems Engineering

In “A time to choose”, Freeman *et al.* (1974) describe the benefits of joint optimization of supply and demand. In reference to “A time to choose”, the

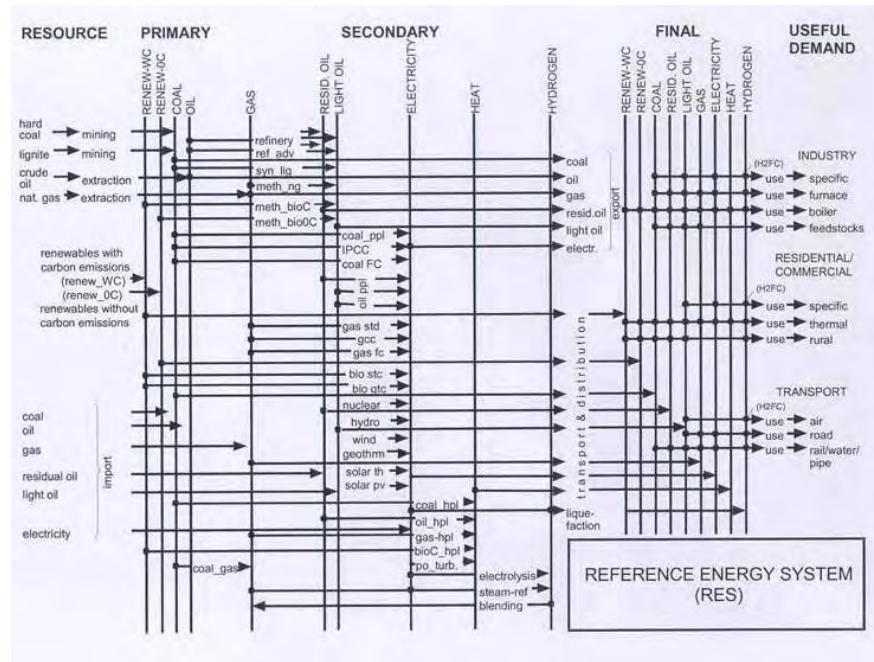

Figure 2.1: Example of Reference Energy System Presentation. (Source: [www.iiasa.ac.at/Research/ECS/docs/models.html](http://www.iiasa.ac.at/Research/ECS/docs/models.html))

Brookhaven Laboratory developed the Reference Energy System (RES) as a formal model of the energy system (Marcuse et al. 1976). The RES captures all energy flows and energy conversions as a graphical model (compare Figure 2.1). The RES is easily transformed into mathematical models. One example is the state-of-the-art model MARKAL. A comprehensive description of MARKAL can be found in (Fishbone and Abilock 1981).

## Demand Side Management

The late 1970's also saw the emergence of another camp of energy engineering approaches under the term 'Demand Side Management' (DSM). Since its inception in the United States, utility DSM has gone through three major eras: (1) information and loans; (2) resource acquisition; and (3) preparation for a more competitive utility industry (Nadel and Geller 1996). Pursuing the **“information and loans”** approach, utilities tried to decrease consumption by educating consumers and offering them loans for the employment of improved technologies and energy management strategies. Limited success of such measures (Collins et al. 1985) led to the **“resource acquisition”** approach, where utilities started to look at conserved power as a resource, a resource potentially cheaper than the construction of new power plants. Thus, utilities offered customers rebates for the introduction of energy saving technologies; e.g. \$5 for each fluorescent



tube installed. The **third era** is characterized by a surge of eager reevaluation of existing programs with a focus on maintaining competitiveness in a deregulated energy market. As the legal monopolies in different countries have been replaced by competing companies, the interest in DSM as regulatory tool decreased somewhat in favor of energy efficiency. However, DSM is gaining renewed attractiveness with progressing development of DSM technologies. Generally, four different DSM strategies may be identified:

**Peak clipping** Utilities manage customer's consumption, e.g., by installing timers for water heaters in order to reduce peak hour demand.

**Valley filling** The idea is to build up off peak loads to fill times with low demand, for instance charging electric cars during night time. The goal is to improve the economic efficiency of a plant.

**Load shifting** This could be accomplished through measures such as thermal storage. Thermal energy storage enables a customer to use electricity to make ice or chilled water late at night when overall electricity consumption is low. The ice or chilled water is then used to cool the building by day when overall electricity consumption is high.

**Conservation** As the most obvious way of saving energy, conservation aims at reducing the entire energy load.

Technologies and measures to pursue the above strategies are abundant and include energy efficient appliances, time-of-use rates, interruptible rates, and many others.

### 2.1.2 Remote Systems

Energy engineering for remote locations, such as islands or remote villages, faces its own challenges and constraints. Lundsager (2005) identifies two general methods for rural energy supplies: grid extension and the use of diesel generators. Grid extensions are often not feasible, because costs of distribution systems are disproportionately high. Existing grid extensions suffer power quality and reliability problems (Vera 2000). Diesel generator sets are the most universal and therefore most common option for electrification of remote locations. However, long transport ways and frequent supply irregularities<sup>1</sup> make the diesel option sometimes unreliable. Particularly in the Pacific, renewable energy technologies appeared to be the ideal solution for supplying remote power (World-Bank 1992). But the application of renewable energies has seen only limited successes, and it is still

---

<sup>1</sup>Irregularities are due to, for example, temporary inaccessibility of access roads or bad weather keeping supply boats from landing at an island.

hard to find many examples of successful renewable rural electrification projects (Fairbairn 1998).

However, new technologies are considered to solve some of the problems. In particular hybrid systems find widespread attention in current research (Wies et al. 2005).

### Island Systems

Energy issues special to the Pacific Islands (Fiji in particular) including the success and failure of past rural electrification projects are discussed by Johnston (2004). Although many problems have to be addressed, the report identifies biofuels as a particularly promising solution for use in rural electricity generation in Fiji. General guidelines for renewable energies in the Pacific are provided in the “Renewable Energy Assessments” guide (Gowen and Wade 1985). The energy demand in Fiji is poorly understood, the last comprehensive survey (Siwatibau 1981) dates back to 1981 (Johnston 2006, personal communication). In order to outline some of the opportunities and typical problems of remote power systems, the following sections analyze a range of examples of remote renewable energy system designs.

### Diesel on the Tokelau Group

An example for a diesel generator energy supply is the South Pacific group of coral atolls of Tokelau (see map in Figure 2.2). Tokelau has a population of about 500 per atoll. Geographically, Tokelau lies about 400km North of Samoa, making it one of the more isolated places in the South Pacific.

The energy system of Tokelau is Diesel generated electricity established in the 1970s. Power reliability is still a big issue despite of a complete upgrade of the electrification scheme by the NZAID-contracted PB Power company. According to Zieroth (2003), reliability is hampered by frequent component breakdown as well as supply irregularities. Table 2.1 summarizes the electricity supply side situation for the Fakaofu atoll. The entire distribution consists of 11kV underground cables with pillar-boxes as access points. At present, the households’ consumption in Tokelau accounts for approximately 90% of the total electricity supplied. For a remote island in the South Pacific, average monthly consumption is extraordinarily high. Most households consume well above 100kWh per month, similar to the consumption pattern of a grid-connected household in New Zealand. For comparison, a household on the Island of Apolima in Samoa, typically consumes approx 30kWh per month (Zieroth 2003). Currently electricity is only supplied intermittently with slightly different schedules for the three atolls. In general, power is switched on around 7.00 – 8.00AM until 3:00 or 4:00PM. The evening supply starts around 5.30PM and ends at around 11:00 or 12:00PM adding to approx 13 hours of daily supply.

Table 2.1: Generation at Fakaofu

Unit	Status
1 Iveco 50kW	Serviceable, requires maintenance
1 Cummins 40kW	Serviceable, poor state, controls malfunctioning
1 Cummins 40kW	Awaiting installation in new power house
1 Cummins 30kW	Serviceable, requires maintenance

The data for this table is given in (Zieroth 2003).



Figure 2.2: Map of Tokelau coral atolls (Source: <http://www.simplemaps.iofm.net>)

### Stand-alone Photovoltaic System with Pumped Storage on Donoussa Island

The next example is of stand-alone renewable energy system as a power supply for the remote village of Merssini (population 20 in 7 houses), Donoussa Island in the Greek Aegean Sea. Manolakos' (2004) report describes the system:

Lighting, TV set and refrigerator were considered basic electricity needs for each house. The photovoltaic array consists of 300 photovoltaic modules of  $60W_{MPP}$ <sup>2</sup> each, for a combined  $18kW_{MPP}$  total installed power. The micro-hydro system consists of a water pump of  $6kVA$  and a water turbine coupled with a DC generator of  $7.5kW$  and two identical water reservoirs of  $150m^3$  capacity each. During the day, the load is satisfied directly from the photovoltaic generator through an inverter (UPS unit of  $25kVA$ ,  $380V$  -3 phases alternative current), while any energy surplus is directed to the pump for pumping water from the low level reservoir (at about  $100m$  altitude from sea level), to the high level reservoir (at about  $200m$  altitude from sea level). During the night, water is turbined to the low level reservoir providing energy to the load. There is also a battery bank of 186 cells of  $2V$  nominal voltage in series, with a total capacity of  $100Ah$ . The batteries cover primarily load peaks.

This system is now operational and provides near to utility grade power to the remote village of 20. The author could not find any information on project cost, but Manolakos (2004) mentions: "The investment cost of the installed stand-alone system is considerably high. The expenditure rises due to the high cost of civil works (water reservoirs) and also due to lack of accessibility (need for road construction) and to high cost of materials transportation." The project has been financed under the European Commission 'JOULE2-CT92-0155' framework.

### Wind-Hydrogen on Utsira Island

In summer 2004, the Norwegian oil company "Norsk Hydro" inaugurated its demonstration Wind-Hydrogen remote energy system on Utsira Island off the West coast of Norway. Utsira has a population of 220 and no local industry. The energy system design is unusual for a remote system in that it aims to mimic the performance of a large scale utility. Two  $600kW$  Enercon wind turbines feed into the mini grid and a  $55kW$  electrolyzer produces hydrogen if excess power is available. In calm periods, a  $10kW$  base load fuel cell combined with a maximum load  $55kW$  Hydrogen engine come online; a concept diagram is shown (Figure 2.3). Thus, this high tech energy system provides utility grade electricity to only ten households. According to Norsk Hydro, the project cost is NOK40 million ([www.Hydro.com](http://www.Hydro.com)) or US\$6.5 million, making it US\$630,000 per household for the initial investment; i.e. such an energy system is not affordable and therefore not desirable.

---

<sup>2</sup>The unit  $W_{MPP}$  refers to the rated PV power output at the maximum power point

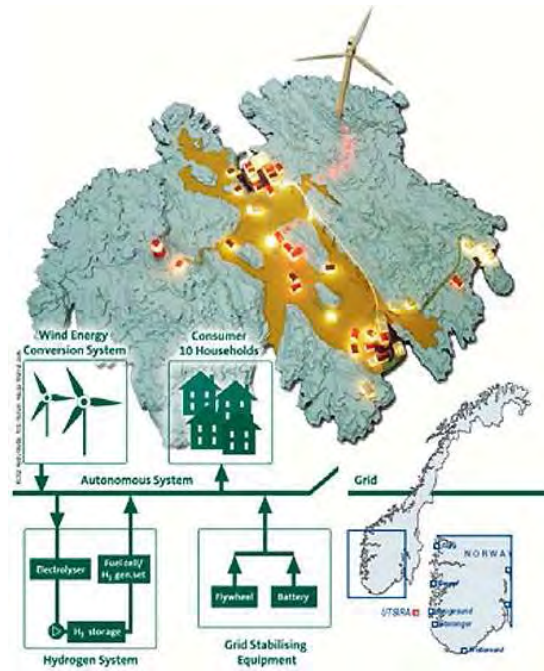

Figure 2.3: Utsira energy supply concept (Source: <http://www.hydro.com>)

### Hybrid Wind/Diesel utility on Porto Santo Island

Porto Santo is a Portuguese island in the North Atlantic Ocean, and part of the Madeira Archipelago. Economic mainstay on the island is tourism which comes with high energy demands, in particular for air conditioning. A hybrid wind power system as central power supply for Porto Santo is described by Duic (2004). Porto Santo is a  $42\text{km}^2$  island (see map in Figure 2.4) with a population between 5000 in off-season and 20,000 during tourist season. The existing hybrid energy system is summarized in Table 2.2. The modular constitution of this system allows for 100% load coverage for the fluctuating demand on Porto Santo island. Technically, the system allows a maximum wind penetration of 30%.

### Energy Service Company on the Kiribati Group

An interesting energy system concept has been pursued by Kiribati Island's Solar Energy Company (SEC). Under grant aid funding SEC commenced its roll as a utility service provider with the installation of 50 household systems on Northern Tarawa (see map in Figure 2.5)(Fairbairn 1998). SEC provides 3 categories of services:

**Category A** Basic package (3 lights plus a night light, but no DC power point for a radio) \$A9.00/month



Figure 2.4: Map of Porto Santo Island (Source: <http://ct1end.netpower.pt>)

Table 2.2: Generation in Porto Santo Island

Type	Capacity
Diesel engine blocks	2 * 3.5MW
Diesel engine blocks	2 * 3.4MW
Vestas wind turbine	2 * 225kW
Vestas wind turbine	660kW
Diesel engine Block	4.4MW

The data in this table is taken from (Duic and Carvalho 2004).

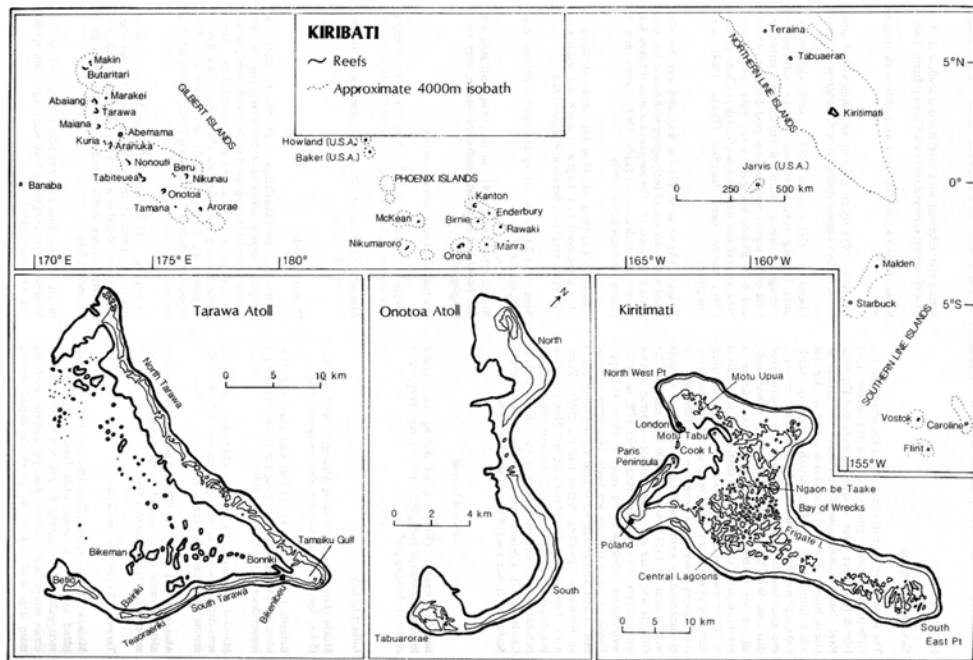

Figure 2.5: Map of Kiribati Group, South Pacific (Source: <http://www.coral.noaa.gov>)

**Category B** Basic package Plus a DC power point \$A10.00/month

**Category C** Basic package Plus a DC power point, plus and additional 11 watt light - \$A11.00/month

Within this scheme, SEC is responsible for installation, operation and maintenance of all installed units. Despite irregularities in management and operation of SEC (Fairbairn 1998), the concept is one of the more successful renewable energy options in the South Pacific.

## 2.2 Modelling Approaches

Many energy modelling programs have been produced, however, most have been used rarely and have not emerged as widely used systems. Energy modelling software ranges from solely technical models over urban planning to economic planning models, most being combinations of the above. Modelling approaches cover a spectrum from linear programming to systems dynamics. The following presents a survey of the relevant range of models.

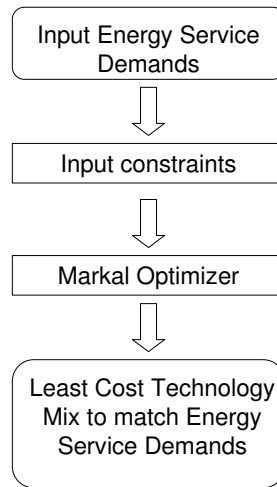

Figure 2.6: Markal - Simplified Flow Chart

### 2.2.1 Markal

MARKAL (Market Allocation) is a technology-rich model for energy-economy-environment systems. It was developed within the International Energy Agency Energy Technology Systems Analysis Programme (ETSAP). MARKAL has been developed to represent the evolution of an energy-environment system at the national, regional, state, or community level for a period of 20 to 50 years. The system is represented as a Reference Energy System (RES) network, where each link is characterized by its technical, environmental (emissions) and economic coefficients. MARKAL finds the “best” RES for each time period by selecting the set of options that minimizes total system cost over the entire planning horizon. MARKAL is documented by (Fishbone and Abilock 1981). Later variations of MARKAL include:

**MacroMarkal** which links Markal with a macroeconomic model in order to provide demands that are endogenous and responsive to price as well as estimates of GDP impact and feedbacks.

**Stochastic** which associates probabilities with the occurrence of each scenario. This is in order to determine hedging strategies to identify robust, rather than purely optimal, strategies.

**Goal Programming** which solves Markal according to the weighted preferences of various stakeholders in order to represent cost versus environmental goals.

### 2.2.2 Deeco

Deeco stands for “dynamic energy, emissions, and cost optimization”. Deeco is being developed by the Institute for Energy Engineering, Technical University



## 2.2. MODELLI

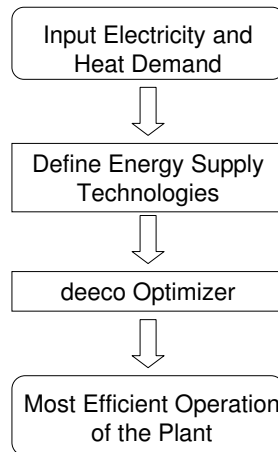

Figure 2.7: Deeco - Simplified Flow Chart

of Berlin, Germany. Deeco is an energy systems modeling environment which is used to define, guide, and evaluate sustainability improvements of all types typical goals include less  $CO_2$  and reduced fossil fuel dependence (Bruckner et al. 2003). The software is based on accurate technical detail and requires ‘high resolution’ information regarding connectivity and ambient conditions (hourly data is often used) in order to capture important network-effects and temporal correlation-effects. Deeco is normally used to compute sustainability gains versus financial cost relative to some assessment of business-as-usual. At the current stage of development, Deeco includes a number of generic technologies including renewable energies. Deeco determines best-practice operation as defined by the selected management objective, using recursive dynamic optimization techniques. Analysis proceeds by comparison with some pre-determined reference case (Bruckner 2001).

### 2.2.3 Leap

LEAP is a scenario-based energy–environment modelling tool described in (Stockholm-Environment-Institute 2005). In LEAP, scenarios are based on accounting of how energy is consumed, converted and produced in a given energy system under varying assumptions on population, economic development, technology, price and more. LEAP uses a built-in technology and environmental database with data on costs, performance and emission factors for different energy technologies.

### 2.2.4 Enpep

The Energy and Power Evaluation Program (ENPEP) is really a set of ten energy, environmental, and economic analysis tools. ENPEP has been developed by the U.S. Argonne National Laboratory with support from the U.S. Department of

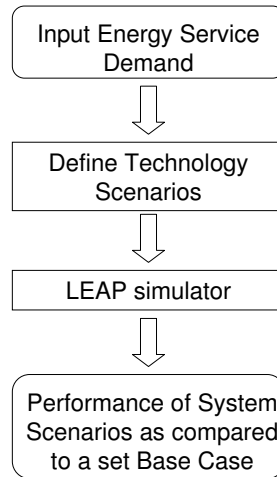

Figure 2.8: LEAP - Simplified Flow Chart

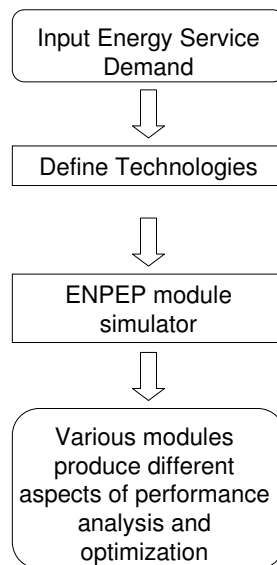

Figure 2.9: ENPEP - Simplified Flow Chart

## 2.2. MODELLI

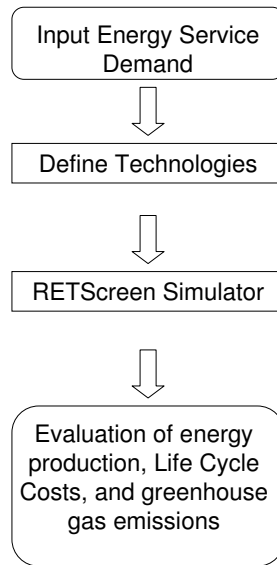

Figure 2.10: RETScreen - Simplified Flow Chart

Energy. ENPEP can be used to evaluate an whole energy system (supply and demand side) but also environmental consequences of different energy strategies. Each module has linkages to other ENPEP modules but is also useable as a stand-alone tool. (CEEESA 2005)

### 2.2.5 RETScreen

RETScreen International Clean Energy Project Analysis Software can be used to evaluate the energy production, life-cycle costs and greenhouse gas emission reductions for various types of energy efficient and renewable energy technologies (RET) (Leng 1998). The software includes product, cost and weather databases. The database provides access to pertinent product performance and specifications data for a number of these manufacturers. The RETScreen software currently includes modules for evaluating: wind energy, small hydro, solar photovoltaics (PVs), combined heat and power, biomass heating, solar air heating, solar water heating, passive solar heating, ground-source heat pumps, and refrigeration.

### 2.2.6 Homer

HOMER aims to simplify the task of evaluating design options for both off-grid and grid-connected power systems for remote, stand-alone, and distributed generation (DG) applications. HOMER's optimization and sensitivity analysis algorithms can be used to evaluate the economic and technical feasibility of a large number of technology options and to account for variation in technology costs

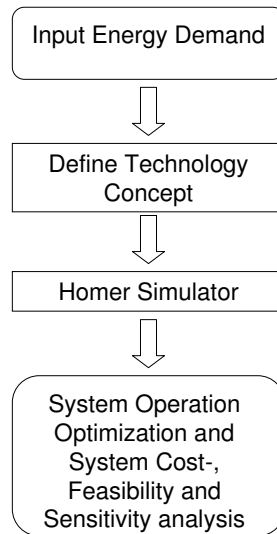

Figure 2.11: Homer - Simplified Flow Chart

and energy resource availability. HOMER is capable of modelling a wide range of conventional and renewable energy technologies. Power sources that can be modelled include: solar photovoltaics (PV), wind turbines, run-of-river hydro power, diesel, gasoline, biogas, alternative, co-fired and custom-fuelled generators, electric utility grids, microturbines, and fuel cells. Storage options include: battery banks and hydrogen. (Baring-Gould 2003)

As a limitation, at the present stage, there is no module to model pumped storage systems.

### 2.2.7 Hybrid2

The Hybrid2 code was developed as an engineering tool to determine the performance of a variety of hybrid power system configurations. Hybrid2 is a part probabilistic and part time series model that uses statistical analysis to model each simulation time step. The Hybrid2 code can model combinations of different power sources and battery storage in AC, DC, or two-bus systems. Hybrid2 also allows for several different dispatch strategy configurations including multiple diesel generators and renewable sources. An economics package is included. Hybrid2 is primarily used for long-term performance forecasts and for providing input to economic analysis. Compared to HOMER, Hybrid2 needs more detailed information about the specific system components and dispatch logic, and thus provides a more accurate assessment of system performance and economic measures. Its probabilistic time series approach makes it well suited to model power systems without storage. (Baring-Gould 2003)

## 2.2. MODELLI

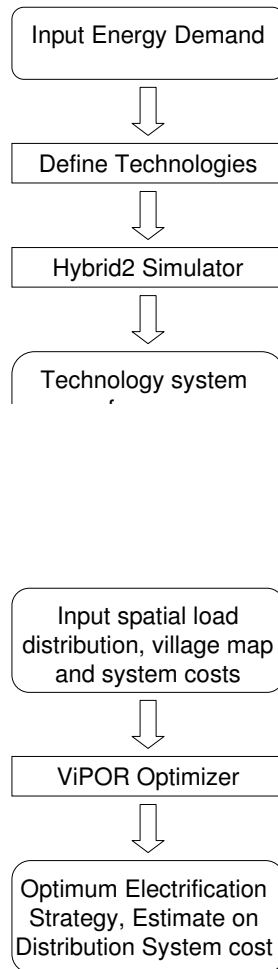

Figure 2.13: ViPOR - Simplified Flow Chart

### 2.2.8 ViPOR

ViPOR stands for ‘Village Power Optimization Model for Renewables’. ViPOR is a model for designing village electrification systems (Baring-Gould 2003). Given a map of a village and some information about load sizes and equipment costs, ViPOR determines, based on a least-cost electrification strategy, which houses should be powered by isolated power systems such as solar home systems, and which should be included in a centralized distribution grid. ViPOR optimizes the distribution grid with consideration of local terrain and low voltage line lengths, and displays a map of the optimal configuration. The model also provides a first-order estimate of the cost of a distribution system for a specific community. The ViPOR model has been validated against standard distribution network electrical models to ensure that the system designs are electrically sound. (Baring-Gould 2003)

## 2.3 Sustainability Concepts

The importance of sustainability is much discussed in energy engineering, and energy issues are at the core of most publications on sustainability. This section outlines sustainability definitions, concepts and frameworks, as well as popular sustainability indicators and indices.

At the core of this research lies the question of how sustainability may link into engineering. Therefore, this research requires a thorough understanding of the evolution and the standard of knowledge of sustainability.

### 2.3.1 Approaches and Methods

In 1968, the Club of Rome formed with the purpose to foster understanding of how the interdependent components (economic, political, natural and social) of our society make up our global system (Meadows and Meadows 1972). Meadows may be considered a pioneer of the sustainability field. In collaboration with System Dynamics pioneer Jay Forrester, Meadows and his team developed the famous ‘world’ model for the analysis of the predicament of mankind. Meadows unearthed a number of positive feedback loops which he related to the many environmental and social problems of all modern societies. Meadows postulated that, in order to prevent collapse, our society must reach an equilibrium state, i.e. to stop exponential growth.

Mathematically speaking, constraints to stop exponential growth are negative feedback loops which in turn can be enhanced by weakening positive feedback loops.

Such constraints can be easily implemented in the software model (e.g. by setting the birth rate equal to the death rate).

However, the question as to how those constraints are achieved in the real world has not been covered in Meadows’ work.

The publication of ‘Limits to growth’ may be seen as the starting point of the ‘modern sustainability debate’. Thirty years later, Meadows published an update to the ‘Limits to growth’ with an analysis of the current state of the world, based on his updated model ‘world3’ (Meadows et al. 2004).

### Brundtland Commission

In 1983 the UN established the World Commission on the Environment and Development in order to look at the world’s environmental problems and propose a global agenda for addressing them. The conclusion drawn from this study was that there was not one defined environmental issue. Rather, social issues like living conditions, resources, population pressures, international trade, education, or health were all entwined with environmental issues. The most famous outcome from the commission meeting is perhaps their frequently recited definition

of sustainable development: “Development that meets the needs of the present without compromising the ability of future generations to meet their own needs” (Brundtland-Commission 1987). How did the Commission translate this philosophical statement into practice?

With regards to a “sustainable energy system” the report gives the following answer; “Sufficient growth of energy supplies to meet human needs (which means accommodating a minimum of 3% per capita income growth in developing countries)” must be ensured.

At the same time the Commission identified the use of fossil fuels and also nuclear power as potentially hazardous and advises to aim at a low energy future. The Commission assumed that the level of energy services of 1980 could be provided by 50% of the 1980 primary energy consumption through increased efficiencies alone. This, they argue, would allow sufficient time for the development of “sustainable energy technologies” which could gradually replace non-renewable energies.

### **Problem Structuring Methods**

Problem structuring methods are mainly applied in corporate strategic planning. However, corporate or regional plans now often include sustainability targets of sorts. Generally these methods are applied to complex planning problems and replace traditional operational research where problems are ill structured, for example, due to missing key parameters (Mingers and Rosenhead 2004). Problem structuring methods are included in this background study for completeness. Examples of well known problem structuring methods are:

- Soft systems methodology (SSM) (Checkland and Poulter 2006)
- Strategic choice approach (SCA)
- Robustness analysis
- Drama theory (Bennett et al. 2001)
- Critical Systems Heuristics (CSH) (Ulrich 2000)
- Interactive Planning (Ackoff 1981)
- Strategic Assumption Surfacing and Testing (Mason and Mitroff 1981)
- Strengths, Weaknesses, Opportunities, and Threats Analysis (SWOT), critically discussed in (Hill and Westbrook 1997)
- Scenario Planning (Schoemaker 1998)
- Socio-Technical Systems Approach (Trist and Murray 1993)

- Viable systems model (VSM) (Harnden 1990)
- System Dynamics (SD) (Lane 2000)
- Decision Conferencing (Phillips 1989)

Numerous individual methods fit into the problem structuring methods category. These methods facilitate systematic ways of understanding dynamic systems.

Problem structuring methods may appear to be the ideal candidate methods for application to sustainability problems and are often applied in this context, and needless to say, their applicability in the context of this work was carefully considered.

However, there is a very important argument against their application: While sustainability problems are complex by nature, Chapter 3 reduces the sustainability problem to a very simple and easily theoretical model.

In light of the subsequent discussion in Chapter 3, the application of problem structuring methods to sustainability problems can be compared to chasing a mouse with a big and clumsy elephant. While it is, of course, not easy to catch a mouse, it must be warned from focusing research efforts on improving the elephant rather than focusing on chasing the mouse.

An almost embarrassing example of a very well known researcher improving the elephant is given in (Rotmans et al. 2000): Rotmans proposes a "strategic" model for sustainable city planning. His proposed Maastricht case study is expected to take a team of ten, i.e. modellers and city planners a couple of years to set up. The model can then run different decisions, and a cockpit like output window gives sustainability indicators for the various planning options. While the scope of involvement and complexity of the model obviously defy any planning reality, it is most curious to Rotmans' note on his sustainability target: "Although the term 'sustainable city' is value-loaded and thus multi-interpretable, it could be characterised as a more balanced development of the social-cultural, economic and environmental domains of a city and its surrounding area." (Rotmans et al. 2000). Figuratively speaking, Rotmans thus proposes to send ten modelers out for a couple of years to build the elephant with minimal understanding of the mouse.

Perhaps, problem structuring methods can help in sustainability planning AFTER better understanding the mouse.

### **Natural Capitalism**

'Natural Capitalism' as an idea emerged in 1994 in the aftermath of the publication of Paul Hawken's book 'The Ecology of Commerce' (Hawken 1993). 'Natural Capitalism' is the result of collaboration between Hawken and Amory and Hunter Lovins of Rocky Mountain Institute. The Lovins in turn were building upon extended collaboration with Ernst von Weizäcker of the Wuppertal Institute in



Germany, culminating in their joint publication ‘Factor Four, Doubling Wealth and Halving Resource Consumption’ (von Weizsäcker et al. 1998).

‘Natural Capitalism’ was published as a “systems approach” with the goal to solve the world’s deepest environmental and social problems (Hawken et al. 1999). The authors show how an adoption of new business strategies can produce growing material wealth combined with continuing economic growth on our way to a more sustainable future. The four central strategies of Natural Capitalism are: (1) Radical resource productivity, (2) Biomimicry, (3) Service and flow economy, and (4) Investing in natural capital.

The authors of Natural Capitalism claim: “...if the entire spectrum of materials savings were systematically applied to every object we make and use, together they would reduce the total flow of materials needed to sustain a given stock of material artifacts or flow of services by a factor much nearer to one hundred, or even more...” (Hawken et al. 1999), p.81. They argue that the technical changes will enable us to save the environment while making more money and raising the GDP (Hawken et al. 1999), p.243.

Lovinses’ analysis does not take into account resource constraints which, for instance, trouble the solar PV manufacturers (Pichel 2006) . The Lovinses take for granted that technical problems with renewable energies will be solved and prices will drop along the economy of scale.

#### **Factor 4**

Factor 4 is an example of the Factor X Club approach to environmental management, an underlying principle of Natural Capitalism. Factor Four advocates argue that resource productivity can and should grow fourfold as a result of doubling efficiency while cutting consumption in half (by increasing demand side efficiency). As such, the amount of wealth extracted from one unit of natural resources would quadruple (von Weizsäcker et al. 1998). Without even mentioning engineering realities, critics of the “energy efficiency means decreasing energy consumption” idea argue: “Economists of all persuasion are united in their belief that the opposite will occur”(Herring 2000). They contend that the effect of improving the efficiency of a factor of production, like energy, is to lower the implicit price and hence make its use more affordable, thus leading to greater use.

#### **Industrial Ecology**

‘Industrial ecology’ is a new approach to the industrial design of products and processes as well as the implementation of sustainable manufacturing strategies. This concept does not view an industrial system in isolation from its surrounding systems but in concert with them” (Jelinski et al. 1992). The ‘Industrial Ecology’ approach seeks to achieve global sustainability by providing their framework

concept to businesses. These businesses are expected to follow the ‘Industrial Ecology’ strategies or otherwise lose their market access due to inevitable loss of interest in their products (Graedel and Allenby 1998), p.20. The most famous product of the Industrial Ecology philosophy is the so called Master Equation (Graedel and Allenby 2003):

$$Env. Impact = Population \times \frac{GDP}{Person} \times \frac{Env. Impact}{Unit\ of\ GDP} \quad (2.1)$$

According to Graedel (2003), it can be assumed most probable that the first term in the equation, population, will continue to grow and at least double in the foreseeable future. He also assumes that the second term,  $GDP/Person$  will continue to grow. That leaves the third term which Graedel refers to as the sustainability term to modify in order to achieve an overall reduction of environmental impact. This will require technological efficiency improvements by a factor of 20 to 50. Graedel (2003) admits that this might be difficult to achieve.

### Indicators for Sustainability

A less well known but comprehensive sustainability framework was established by Hartmut Bossel. In a nutshell, Bossel (1999) identified six basic “orientors” which represent a system’s state. The orientors are existence, efficiency, freedom, security, adaptability, and coexistence. Every orientor needs to satisfy a minimum condition for the whole system in order to be sustainable. While Bossel’s approach is logical and comprehensive, it is unclear how the sustainability indicators may be used by planners.

### The Natural Step

The Natural Step (TNS) is internationally promoted as a framework in order to direct public and corporate decision-making towards socioecological sustainability. TNS Founder Robert wanted to facilitate the dialogue between scientists and business decision-making. He identified different levels of strategic planning for sustainable development (Robert 2000):

**Level 1** System Definition: Articulation of how the system is constituted.

**Level 2** Identification of Outcomes and Success: Principles for setting the vision and guiding strategy.

**Level 3** Strategies: A means of moving purposefully toward the vision.

**Level 4** Actions: Concrete measures that will lead to the desired outcomes.

**Level 5** Toolbox: Means of assessing, managing and monitoring actions.

The TNS concept is frequently applied to businesses, a famous example being the world's largest furniture retailer IKEA.

However, the scientific value of TNS is disputable. Upham (2000) recently completed his dissertation on the evaluation of TNS framework with the conclusion: "TNS theory includes implicit reasoning and value judgement as well as science".

### **Permaculture**

The permaculture concept was established by David Holmgren and Bill Mollison in the 1970s. Initially developed as a concept for sustainable agriculture, the scope of permaculture was extended to sustainable culture. Holmgren (2002) established the following twelve principles for permaculture:

1. observe and interact,
2. catch and store energy,
3. obtain a yield,
4. apply self-regulation and accept feedback,
5. use and value renewable resources and services,
6. produce no waste,
7. design from patterns to details,
8. integrate rather than segregate,
9. use small and slow solutions,
10. use and value diversity,
11. use edges and value the marginal, and
12. creatively use and respond to change.

While the previous approaches to sustainability aim at ways to make our modern established way of life sustainable, permaculture provides an alternative way of life that might be inherently sustainable. A drawback of the permaculture concept is that it is not applicable to our urban forms of life.

### **Five Point Framework**

Jared Diamond, (2005) provides a scientific historical perspective of sustainability. He systematically analyzed past and present societies in order to determine which factors contributed to a society's failure or success. For this assessment, Diamond developed a 'Five-Point Framework' of possible contributing factors: (1) Environmental Damage, (2) Climate Change, (3) Hostile Neighbors, (4) Friendly Trade Partners, (5) Society's Response to Environmental Problems.

Before Jared Diamond, the most famous study of societal collapses was published in Tainter's 'Collapse of Complex Societies' (Tainter 1990). Tainter's concept of societal collapse was that each society has a characteristic problem solving strategy which is inevitably subjected to the law of diminishing returns. In contrast to Jared Diamond's approach, Tainter's theory is abstract and hard to quantify.

## **2.3.2 Sustainability Tools**

### **Life Cycle Assessment**

Life Cycle Assessment (LCA) is perhaps the most widespread and most universally accepted tool for sustainability analysis of materials and products. Subject to investigation are the total resource flows involved in the production and distribution of a product (Heijungs et al. 1992), (Lindfors et al. 1995).

### **Ecological Footprinting**

Another well-known sustainability indicator tool builds on the Ecological Footprinting methodology for the evaluation of the ecological impact of human activities (Rees and Wackernagel 1994). In Ecological Footprint analysis, the amount of ecologically productive land, sea and other water mass area are estimated that are required for sustaining a population, or to manufacture a product. Quantities accounted for are the use of energy, food, water, building material and other consumables. The results are converted into a measure of used land area in 'global hectares' (gha) per person.

### **Triple Bottom Line Accounting**

This term found public attention with the 1997 publication of the British edition of John Elkington's "Cannibals With Forks: The Triple Bottom Line of 21st Century Business" (Elkington 1998). Advocates of the 'triple bottom line' paradigm encourage managers to think in terms of not just the good old fashioned financial bottom line, but in terms of two additional 'bottom lines', namely the so-called 'social bottom line' and 'environmental bottom line' (Norman and

MacDonald 2003). The idea of a Triple Bottom Line refers to ethical business practices and does not directly affect resource continuity.

### Sustainable Technology Development

Sustainable Technology Development (STD) refers to a five-year research program by the Dutch government. Taking a sustainable future vision as a starting point, STD demonstrated what steps should be taken today for new technologies and systems to be in place in time (Weaver et al. 2000).

## 2.4 Imminent Petroleum Shortage

This section covers literature on petroleum forecasting and peak oil. General options for mitigation are briefly discussed.

### 2.4.1 Petroleum Production Predictions

In 1956 Marion King Hubbert published his study of the lifetime production profile of typical oil companies, where he accurately predicted a peak in American oil production to occur between 1966 and 1972 (Hubbert 1956); the actual peak occurred in 1971. Since Hubbert's death, several prominent petroleum geologists published their own forecasts based on Hubbert's methodology. A selection of such predictions is given in Table 2.3.

Table 2.3: Predictions for Peak in Global Oil Production

Global Peak	Forecaster	Background
After 2007	Skrebowski (2004)	Petroleum journal editor
Before 2009	Deffeyes (2001)	Petroleum geologist (ret.)
Before 2010	Goodstein (2004)	Vice Provost., CalTech
Around 2010	Campbell (2003)	Petroleum geologist
2010–2020	IEA (n.d.)	Internat. Energy Agency
No visible peak	Lynch (2003) and Lomborg (2001)	Economists

A declining number of critics dismiss those prediction as unrealistic. In “The Skeptical Environmentalist” political scientist Bjørn Lomborg (2001) disputes that most previous predictions of oil shortages were wrong because we are constantly discovering new oil which the predictions do not take into account. Though what Lomborg does not take into account is that the rate of discovering

new oil has been steadily decreasing since its peak in the 1960's (Campbell and Laherrere 1998). Lomborg's second argument is that many previously closed oil fields still hold up to 60% of their original reserves which we will be able to extract as extraction technology advances. However, those additional reserves have already been accounted for in Campbell's (1998) estimates. Lomborg also contends that hundreds of millions of years of biological evolution prove that nature is always finding ways of putting more energy to use. Huber takes this argument one step further by comparing this 'mechanism' with a "perpetual-motion machine" (Huber 1999).

### 2.4.2 Peak Oil Mitigation

A detailed analysis of potential non-polluting energy sources has been undertaken by (Hoffert et al. 2002), who conclude that "Energy sources that can produce 100 to 300% of the present world power consumption without greenhouse emissions do not exist".

In "The Party's Over", Heinberg (2003) provides a broad discussion of existing fossil and alternative sources and how we could put them to use. For the analysis of potential energy sources, Heinberg suggests using four main criteria:

1. Energy Returned on Energy Invested (EROI)
2. Renewability
3. Environmental Costliness
4. Transportability and Convenience

Heinberg found that it will be physically impossible to fill the imminent difference between oil supply and demand by any combination of alternative resources. According to Heinberg, we will not be able to sustain today's power consumption beyond the global oil production peak. This view is endorsed by some of the world's most renowned oil geologists, see e.g. (Deffeyes 2001), (Campbell 1997), or (Duncan and Youngquist 1999).

While literature on possible implications of peak oil and imminent catastrophes is abundant (e.g. (Kunstler 2005)), suggestions on possible mitigation are rare. Hirsch (2005) developed three different oil production scenarios, and investigated what options there are to mitigate the imminent risks posed by peak oil. Peak oil is inflicted with various uncertainties, such as the year of peaking and also the immediate effects. Thus, peak oil is a typical risk management problem (Hirsch et al. 2005). Hirsch found that our options for successful mitigation strongly depend on the time period between the inception of mitigation crash programs and the date of peak oil. A significant supply shortfall could be avoided if mitigation programs started roughly twenty years before world oil peaking.

# Chapter 3

## Preliminary Theoretical Considerations

A sustainable society can be achieved only if it has a sustainable energy system. But a sustainable energy system can be designed only if the concept of a sustainable society is understood. Section 2.3 introduced popular concepts of sustainability, but it remains to trace the role of energy engineering therein. Some concepts, most notably ‘Natural Capitalism’ or ‘Industrial Ecology’ (Hawken et al. 1999), (Graedel and Allenby 1995) would appear to give futile directives to energy engineers by demanding increases in resource productivity that can be achieved only with technologies that do not exist using resources that do not exist. Graedel (2003) indirectly questions the credibility of this approach in saying that sustainability can be achieved only by increasing technological efficiency by a factor of 20 to 50. Other researchers try to conceptualize energy systems with reduced emissions and renewable energy components that may be achievable in the future if costs were to decrease ( e.g. (Groscurth 1998)).

Krumdieck (2007) proposes that economics, engineering and science cannot independently fix the serious energy supply and environmental problems now facing us by simply focusing on component level projects such as extracting more renewable energy, efficiency improvements or consumer behavior changes. Sustainability must be addressed in a new, systems-level, multidisciplinary approach. This thesis ties into Krumdieck’s theoretical model of regional energy systems. The model is briefly discussed in the following sections, and the role of this research is pointed out by means of the model.

### 3.1 Feedback Control Model of Regional Systems

A useful introduction to the theoretical model is an analogy borrowed from (Krumdieck 2007):

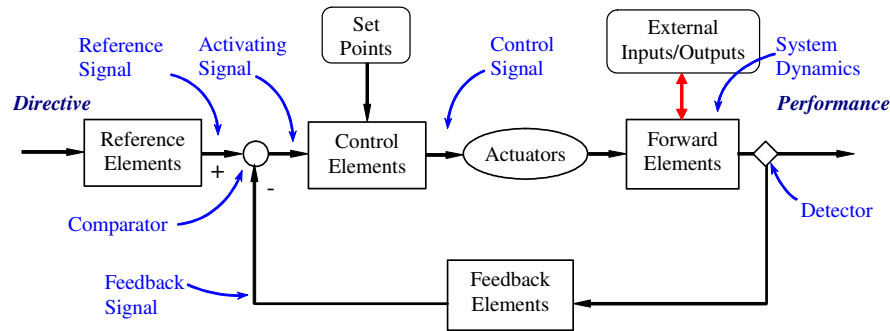

Figure 3.1: Standard presentation of a feedback control system. Figure taken from (Krumdieck 2007)

For example, any graduate mechanical engineer understands that there is only one way to put together a compressor, heat exchangers and a throttle to make a heat pump. Operation of a thermodynamic system like a heat pump requires information, measurement and control at the systems-level. For example, the compressor, which increases refrigerant pressure, is not turned on in order to increase compressor consumption, but because a temperature measurement in the home was interpreted by a controller to mean that heat was required. In engineering, we understand that systems are not simply a collection of components. ... Optimal system performance depends on coherent operation of components, not independent best interest of components. (Krumdieck 2007)

To date, regional energy systems have been developed mainly from a component-level perspective. This worked so far, but only because system capacities far exceeded demand. Krumdieck argues that a grossly oversized system can be reliable but does not make for an efficient use of resources. If available resources and environmental limits exhibit system constraints, efficient system designs require these constraints to be incorporated in relationship between suppliers and consumers.

### Control Systems Engineering

In engineering, modelling, analysis and control of dynamic systems presuppose the application of control theory (Palm 2000). The basic form of a control system is illustrated in Figure 3.1. The system goal or directive is represented by the input reference elements. The comparator determines the difference between reference and feedback and feeds this difference forward to the control elements. Control elements convert this to a control signal which in turn causes physical changes in the system actuators. The actuators affect the performance of the forward elements, i.e. the physical plant. The performance is measured by detectors and feedback elements convert the detector signals to the same calibration as the reference signal.



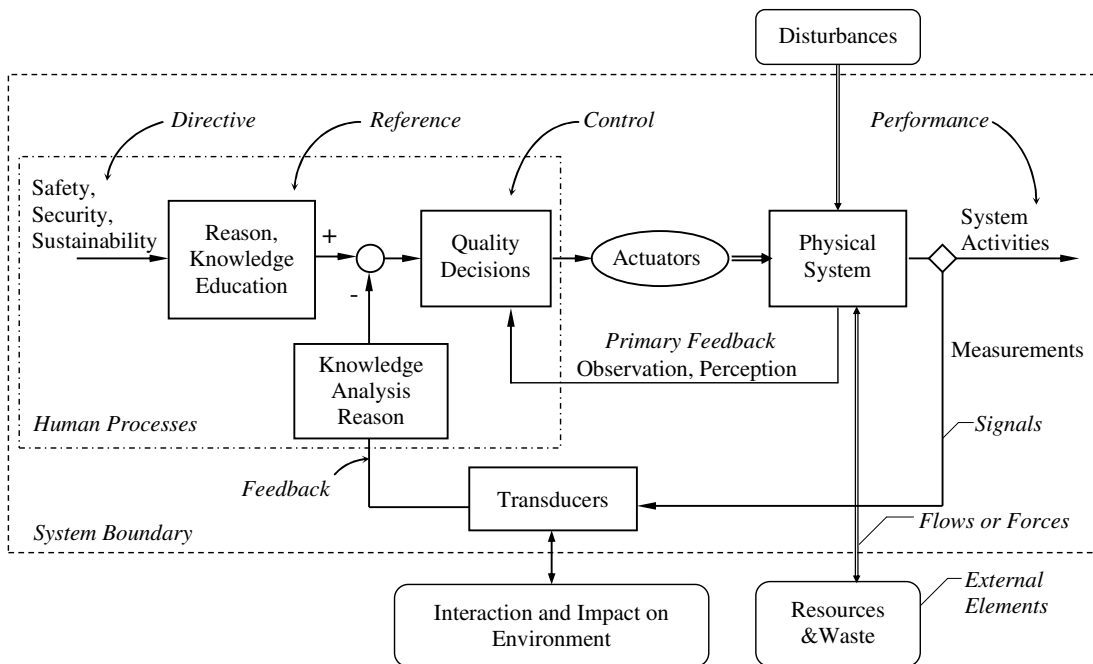

Figure 3.2: The regional energy-environment-economy system model according to (Krumdieck 2007).

If the cruise control of an automobile is used as an example, the directive would be a desired speed that is deemed safe and sustainable for the given circumstances at a time. In this case, the system performance would be the actual speed. The controller would be a microprocessor which passes control signals on to the actuators, i.e. fuel supply throttle and brake fluids. These affect the performance of the physical plant which is the whole vehicle. Speed transducers detect the actual speed, and electronic calibrators (feedback elements) feed the signal back to the comparator. Krumdieck (2007) proposes “that the engineering and economics of sustainable anthropogenic systems can be understood by modelling the regional energy system as a feedback control system”.

### Regional Systems as Control Systems

The term “regional energy system” describes the energy supply and distribution infrastructure, the energy consuming devices, the people in a geographical region, and the environment as both, provider of resources and recipient of impacts. The general form of Krumdieck’s theoretical model is shown in Figure 3.2. Krumdieck (2007) defines the system as “any community of people, their relationships with each other through economic activities, the infrastructure that they use in these activities, including appliances, buildings, etc. within a given environment and resource setting”. It is important to note that this is a model representation of the dynamics of the system. Changes in technology, built environment, or

resources would change the system, and would therefore require an adaptation of the dynamic model to the new circumstances. For instance, while the fundamental model of describing the behavior of a VW and a BMW is the same, the particular models for each vehicle would be unique.

Referring to Figure 3.2, the **Directive** for a society is a shared cultural vision. This vision depends strongly on cultural values, but perhaps is summed up best as peoples' desire to survive. The most predominant needs are not consumption but safety and security which is given in a system that works without major disturbances. Perhaps the most primordial need is sustainability, or continuity. For example, it is not an isolated case that a mother has compromised her own life for the sake of her child.

The **Reference Elements** are represented by sustainable levels of resource consumption and environmental impacts of a community carrying out their nominal activities.

The higher level directives are processed into the specific reference signal by means of knowledge, reason and education of the society. In other words, determining a sustainable, safe and secure level of consumption, and impacts to support a certain level of activity would require a concept level system model for a specific region employing some specified set of technologies. (Krumdieck 2007)

Methods to assess the safety risks of appliances and the security of electricity supply systems are available. However, at present no tangible method is available for sustainability assessment of regional energy systems.

A new method for the development of a sustainable regional energy system is proposed in this thesis. The sustainable regional energy system would be the reference input in Krumdieck's theoretical model. The question sought to answer is: "What would a sustainable society in this particular region look like?"

Ancient societies usually had established reference signals allowing them to understand their relationships to natural systems. This was no static knowledge, this was knowledge that had been developed and adapted throughout generations of observers and experimenters. Diamond (2005) found that the only one factor that was instrumental in every single society's failure or success was their reaction to environmental problems. How this worked was different from society to society. But regardless of a society's political persuasion and structure, effective mechanisms for reference signals were or were not in place.

The method proposed herein is based on comparative risk assessment, a tool that is particularly suitable for handling the complexities of a modern-day regional energy system which is afflicted with several uncertainties.

Usually, a control system has several different **Feedback Elements**. In her model, Krumdieck designates the two main feedback signals primary and general. All people make use of primary feedback directly and continuously to function effectively. As the main source of information for the system control, the primary

feedback, for example the knowledge of prices of cigarettes in different supermarkets, is directly observable. The general feedback includes information about the aggregate impact of activities on the environment, something that is not directly observable by individuals but by special observers.

The **Comparator** outputs the difference between feedback of actual measured consumption and impacts against the reference levels. It is easy to understand how this would have worked in traditional societies: the indigenous knowledge of how to carry out day to day activities in a sustainable way would have been a strong shared cultural vision; the impact of people's activities on local resources would have been observable and understandable to people who relied on those resources for survival. Krumdieck (2007) writes:

In his recent book, *Collapse*, Jared Diamond (2005) sets out the theory that some societies choose to continue activity systems that lead to environmental collapse even though the problems must be observable. The regional energy system model can be seen to accurately represent this type of behavior. For example, Diamond describes the behavior of the Greenland Viking colonists who continued their shared cultural vision of behavior and resource utilization, even though it did not fit with the Greenland environment. He explains that in a land teeming with fish, the people starved to death rather than break with their traditions as cattlemen and hunters. At this point it may be evident to the reader that our modern society is in a similar quandary, where our shared cultural values and vision are not reconcilable with environmental sustainability. The public are receiving more and more feedback information about global climate change, for example, but that information does not have any cultural reference of a non-globally destructive activity system and so the information produces no signal to activate the controller to bring the system back into a safe, secure and sustainable mode of operation. Electronic measurement signals in the cruise control system are processed into signals like vehicle speed which can be compared to the set speed. In the same way, ecological and environmental monitoring must be processed into information that is directly related to daily activities and which is relevant to known sustainable conditions. Clearly, there is a great opportunity and necessity for development within our society in this area. (Krumdieck 2007)

The **Control Elements** determine necessary changes to the actuating elements required for system operation according to the reference. The controller in Krumdieck's model is an aggregate of day to day decisions by individuals. Decisions are made to maximize quality within the context of culture and available built environment.

**Actuating Elements** are represented by the economy. If a decision is made that more heat is required in a home, people would access a heater through the economy. Krumdieck (2007) argues: "Popular opinion might be that cost drives

people's decisions about consumption. However, the control system model indicates that economic relationships are actuators that determine how people access the goods and services they decide to purchase to meet their needs and quality desires, not the reason they have desires or participate in activities. There may someday be information about the resources being used to provide the electricity, and people may develop a reference vision of minimizing evening peak loads to maintain secure supply and eliminate the demand for fossil fuelled generation."

**Forward Elements** are the physical system, the built environment. The built environment is the physical frame of where and how activities may take place. The built environment experiences **flows across the system boundary** and **disturbances**. Krumdieck describes external flows as such: "The activities of people in a region require material inputs from the environment both inside and outside of the system boundary. The activities in the region may also produce products and wastes that move across the system boundary. Control system theory deals with these externalities as material inputs and outputs to the physical system. For the example of the cruise control system, the level of fuel in the tank is not a part of the speed control system. However, the constant speed can only be maintained as long as the flow of fuel continues to flow to the engine. The sustainable supply and export of resources would need to be determined based on the source or sink environments. Activities and technology can be changed in many ways, which we term disturbances, even though the changes may include innovation and technology development. At any given time, the existing built environment and appliances are used as intended; people prepare their dinner, children read books, shops provide goods, milk is processed etc. If a new regulation, a new behavioural pattern, or a new technology becomes part of the system, then it has essentially "disturbed" the original system."

### **Terminology - Sustainability and Anthropogenic Continuity**

The term sustainability can be used in various contexts. For example, a sustainable business is one that continually grows. Renewable energies are often generally called sustainable, even though they occasionally produce more environmental damage than a fossil alternative.

In order to distinguish this research from other work under the same label, sustainability shall herein be referred to as Anthropogenic Continuity.

To clarify the meaning of this: Anthropogenic Continuity does not refer to a static state of a society. It is recognized that anthropogenic systems are never static and are generally in a continuous process of change and adaptation. Anthropogenic continuity shall refer to the ability of the dynamic anthropogenic system to continue without major disruptions.

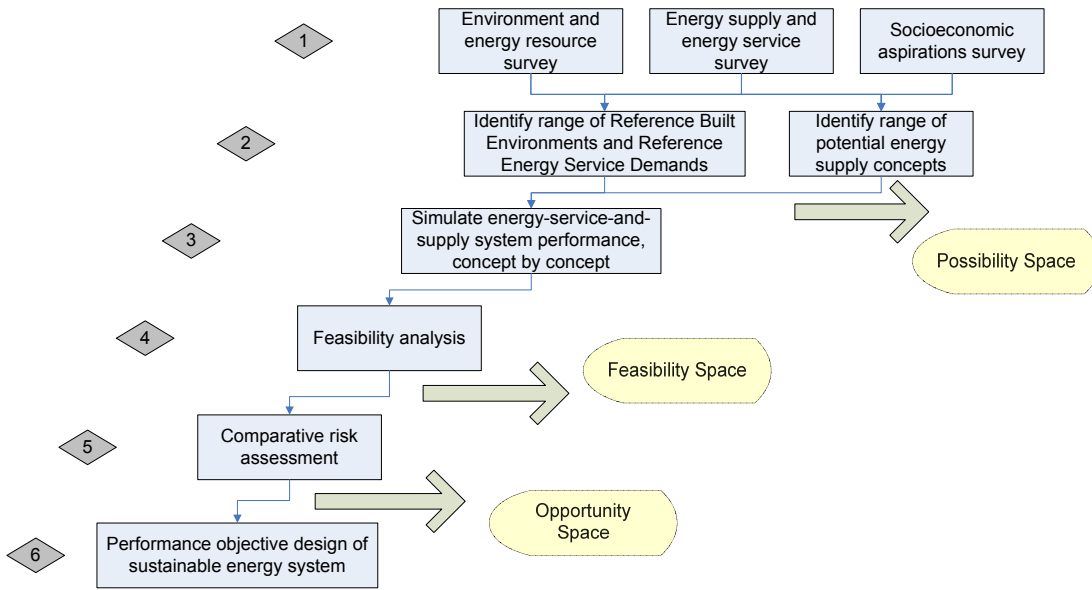

Figure 3.3: Methodology overview.

## 3.2 Strategic Analysis Method

The previous section gave a brief introduction to Krumdick’s theoretical model of regional energy systems, and pointed out the position of this research in the wider model context.

As illustrated above, the role of the new method is to identify possible options for sustainable regional energy systems within (1) environmental and (2) resource constraints.

The method proposed here is based on (a) generating energy service-and-supply-system concepts, and (b) evaluating the concepts according to their resilience towards constraints. An overview of the method is shown in Figure 3.3. The illustration highlights three provisional outcomes: possibility space, feasibility space, and opportunity space. In brief, the possibility space represents the sum of energy-service-and-supply concepts that have been identified up front. Through the application of feasibility and risk analyses, the possibility space is reduced in two stages to feasibility space, and then the opportunity space. The six logical steps of the method in Figure 3.3 are explained in the following sections.

### Step 1 – Surveys

The first step is a detailed survey of the regional energy environment system. The first of three main survey components is a survey of the local environment and the local availability of potential indigenous and non-indigenous energy resources. The second component is a survey of the present energy-service-and-supply system, and the last component is a survey of socioeconomic aspirations of the local

population. The survey results should provide a profound understanding of (a) opportunities and limitations posed by the local environment and available resources, (b) the existing energy system including the services provided and the energy supply system, and (c) the range of aspirations of the population.

Next to the main focus of surveying electricity, all other forms of energy use warrant a degree of attention; this is essential for an overall understanding of energy services and flows in the region, and of understanding the position of electricity generation in the wider picture of local energy flows. On the supply side, data is collected on the system layout, system condition, and system operation. Demand side analysis is done by means of an assessment of the energy services supplied, and the use and importance of these services to the people. Possible outcomes include appliance penetration data, energy expenditures, energy use distributions, and energy flow charts.

All significant local energy resources are assessed in terms of available quantities and accessibility. The data for all possible energy resources is plugged into subsequent energy models.

A novel part of an otherwise fairly standard series of surveys is the survey of development aspirations. This part adds a new dimension to traditional energy planning procedures. While it is traditionally assumed that consumption growth and economic growth are the ultimate objectives of an energy system, in the context of anthropogenic continuity, it is more useful to work towards providing energy services that allow people to do what they request to do. A survey of aspirations should identify a spectrum of aspirations of how different groups of the population would like to see their lives in the future. The survey should pinpoint three or four representative visions. These representative visions are, in the next step, translated into characteristic built environments which would allow the envisioned ways of life to materialize.

## **Step 2 – Concepts**

A level of energy consumption is one of the decisive factors that characterize a society. An energy service level is characterized by a particular lifestyle, and a particular lifestyle occurs because it is supported by the infrastructure, or in a wider sense, the built environment. This step of the method describes the transformation of people's aspirations to something tangible, something that can be analyzed with engineering methods. It is assumed that the electricity aspect of a built environment is a function of the energy service level and the local climate. If possible, appliance use profiles are created from empirical data; that is appliance use profiles from regions with similar climates and similar energy service levels. Otherwise appliance use profiles are estimated. Appliance use profiles are used to model an energy demand in the form of an electricity load curve. The process leading from Reference Built Environments to electricity load curves is illustrated in Figure 3.4. There is a built-in loop, which means that the

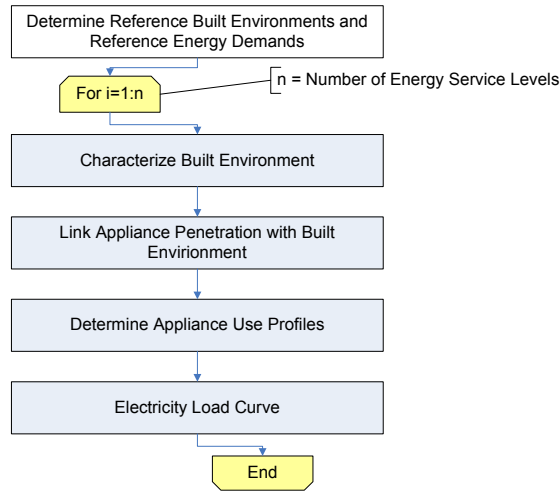

Figure 3.4: From Reference Built Environment to electricity load curves.

process is to be repeated for each one of the identified development levels.

### Step 3 – Energy System Simulations

Once reference load curves have been determined for each of the identified energy service levels, energy models are developed with different energy supply options. The available energy resources as identified during the surveys determine the energy supply options. Only *commercially proven* and *technically feasible* technologies shall herein be considered. Combining  $m$  energy service options with  $n$  energy resource options results in a total number of  $n \times m$  basic energy system options. System sizing and requirements, investment, life cycle costs, and cost of energy are computed separately for each option.

### Step 4 – Feasibility

Feasibility studies are performed on all energy concepts and from there the key issues are identified. An issue is defined as a problem that needs to be resolved for successful implementation of the product. If an issue has presently no solution, the issue is treated as a risk with probability and impact, and adds to the collection of system risks.

However, if an issue has currently *no possible* solution or is afflicted with an unacceptably high risk it becomes an obstacle. In the context of this methodology, every concept with an obstacle-type issue is discarded at this stage. The possibility space thus reduces to the feasibility space.

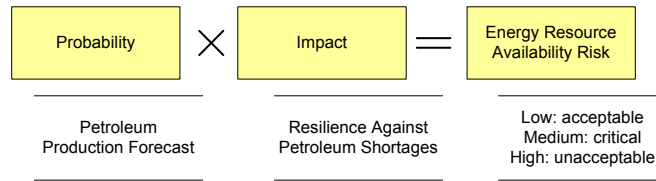

Figure 3.5: Determining the risk of fuel shortages.

### Step 5 – Comparative Risk Assessment

Risk assessments always begin with setting out the context of the risk management problem at hand (Elms 1998). In this case, the overall strategic goal is anthropogenic continuity. The alternative to anthropogenic continuity is collapse of a society. A tangible concept explaining the collapse of previous societies has been published by (Diamond 2005). According to Diamond, there are five fundamental factors which are essential to the study of collapse: 1) environmental damage, 2) climate change, 3) hostile neighbors, 4) friendly trade partners, and 5) society’s response to environmental problems. Two of these factors, ‘climate change’, and ‘hostile neighbors’ are beyond the scope of this engineering analysis. Petroleum supplies to and shortages within a region are covered under the ‘friendly trade partners’ factor. Diamond (2005) found that his fifth factor, ‘society’s response to environmental damage’ was the single one factor which played a role in the failure of *all* societies that failed. In an effort to learn from others’ mistakes, this research is dedicated to contribute to improving a society’s response to environmental problems.

Two out of the five factors Diamond introduced are suitable and appropriate for risk analysis to anthropogenic continuity in the regional energy planning context: 1) Resource availability to supply candidate energy systems (‘friendly trade partners’) and 2) Environmental problems.

#### A. Resource Security

Figure 3.5 illustrates the evaluation of the risk to us caused by declining conventional oil production. The probability for this risk is determined on the basis of petroleum production forecasts. This is difficult to analyze, because of the inherent uncertainties in assessing petroleum availability (Hirsch et al. 2005). At the current standard of knowledge in petroleum geology, it can be taken for a fact that global petroleum production will peak. Due to unreliable reserve estimates and production data, however, it is unclear when the peak will occur. Also unclear is what the supply situation in a specific country will be, relative to global fuel availability. For member countries of the International Energy Agency (IEA), the IEA is to provide resource security by rationing energy supplies in a shortage situation. For non-members the supply situation is less predictable.

It is here proposed to keep analysis independent of the exact year of peak



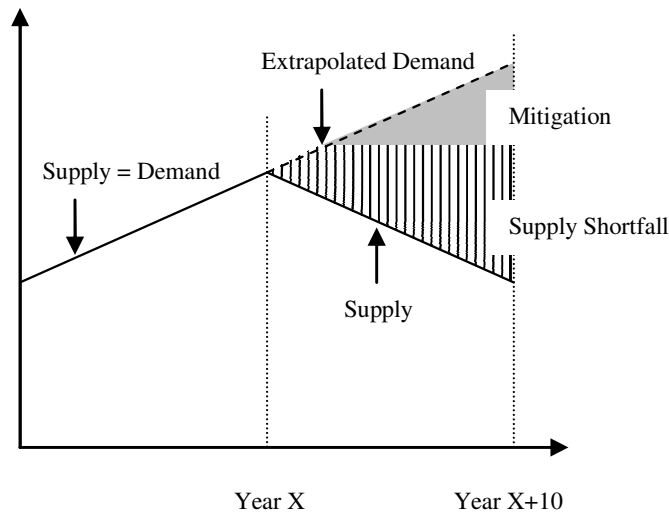

Figure 3.6: Modelling Fuel Supplies, after (Hirsch et al. 2005)

oil occurrence. In order to facilitate meaningful analysis, it is assumed that the energy service options derived in the previous sections are fully developed and fully functional at the year of peak oil, whatever the exact year may be. Lacking more detailed data, it is assumed that fuel supply to a specific country will follow a similar trend as global fuel supply. Post-peak global fuel supply is here modelled according to Hirsch (2005). Hirsch modelled three different scenarios of mitigation to the petroleum supply risk assuming 20 years, 10 years, and 0 years of preparation time for a strategic risk management program. It is here assumed that there will be no preparation time, and that mitigation of the petroleum shortage problem will commence only after peak oil happens. This is a valid assumption in case peak oil happens soon, i.e. in less than ten years from now. Dantas et al. (2006) proposed two methods for calculating the probability of peak oil occurrence in any given year. A conservative approach yielded a 40% likelihood for peak oil occurrence before 10 years from now, i.e. before 2016. But what they believe to be a more realistic approach suggests that the likelihood of oil peaking within 10 years from now is closer to 80%. The global energy supply scenario after Hirsch (2005) is shown in Figure 3.6. Year X refers to the unknown years of peak oil. The supply for the 20 years time span considered is approximated by an annual 2% rise in petroleum production up to year X, and a production decline of an equal 2% per annum thereafter. The mitigation wedge in the figure results from a mix of energy savings through efficiency, and substitute fuels to replace petroleum products.

Additional to the risk of petroleum supply shortages, risks to other resource shortages, such as the supply of coconut oil or the supply of photovoltaic panels, should be considered, depending on the resources proposed in the respective concepts.

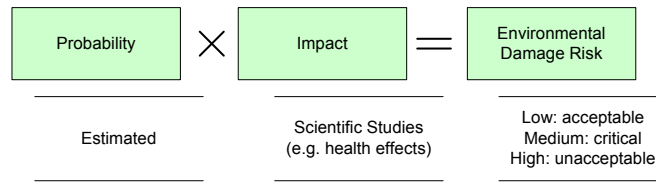

Figure 3.7: Risk through Environmental Damage.

## B. Environmental Damage

Risk analysis for environmental damage is assessed as indicated in Figure 3.7. Impacts are on the basis of direct as well as indirect damage. Direct damage shall be referred to as damage or degradation to be nominally expected during the lifetime of an energy plant. Indirect damage shall be damage caused not by the energy system but by various other consequences from a strategic energy service level. The issues involved in assessing the risk to environmental damage are highly complex. In order to preserve transparency and comparability, the analysis is, in this research, held at relatively high level. Where reasonable, risks are assessed quantitatively. Otherwise qualitative analysis is used.

### Step 6 – Performance Objective Design

The results of the feasibility and risk assessment studies reduce the number of technically possible options (the Possibility Space) to reveal the options that incur acceptable risks to anthropogenic continuity of the society (Opportunity Space). The opportunity space is to be seen as an indication for real opportunities for the conceptualization of a sustainable energy system. In the last step of the methodology, a system is designed, based on the risk assessment results. The energy -service-and-supply system design follows a standard engineering product design process.

### Summary

In this research, sustainability is defined as Anthropogenic Continuity. Anthropogenic Continuity does not refer to a static state of a society. Anthropogenic systems are never static and are generally in a continuous process of change and adaptation. However, it is also possible that this continuity of regional anthropogenic systems is, often painfully, interrupted by various forms of crises. It is therefore the utmost concern behind this research, to mitigate the risks to the Continuity of our Anthropogenic Systems. It is fully recognized that the mitigation of this risk is likely to involve much more than replacing fossil fuels with renewable energies; hence the approach to expand the scope of analysis to include various levels of energy service. The employment of risk analysis ultimately allows for articulate communication of analysis results. Risk is a language spoken

throughout professional disciplines. Communication of the results leads the audience from the easily understood possibility space, through risk analysis, to the opportunity space. The opportunity space includes only those energy system options which inherently pose manageable levels of risk to the Continuity of the Regional Anthropogenic System.

# Chapter 4

## Introduction to Rotuma Island

The method described in the previous chapter is put to the test by means of a case study. Finding a suitable case study has been a twofold challenge: because of the systems scope, the method needed to be investigated with the scope of one complete regional energy system. Case studies under consideration included Lyttelton, a suburb of the city of Christchurch, New Zealand. However, all parts of the city are so economically and energetically interlinked that resource flows would be difficult to track. A new window of opportunity opened when someone from Rotuma asked the author's advisor, Dr. Susan Krumdieck, for assistance with severe energy problems on the island; Rotuma is small and isolated. Infrequent boat services make resource flows easy to observe. Although today Rotuma is a territory of Fiji, the population is a separate people, with their own language and culture. By Western standards, Rotuma has a low level of energy service development. The island features some motorized transport. Diesel generated electricity is available to parts of the island on a frequently interrupted schedule with electricity hours ranging from three to six hours after dark. This chapter is an introduction to Rotuma. Topics treated below include the local geography and climate, the lifestyle, daily life and the Rotuman economy.

### 4.1 Geography of Rotuma

Rotuma is one of the most isolated islands in western Polynesia. It is located at  $12^{\circ}30'S, 177^{\circ}E$ , about 500km northwest of Cikobia, the northernmost island in the Fiji group. Rotuma's geographical position is shown on the map in Figure 4.1). Rotuma is of volcanic origin and dates back to Pleistocene age (Woodhall 1987). The main island has an area of  $43km^2$  and, except for a small opening around Oinafa point, is surrounded by a fringing coral reef. Island and reef are situated on the eastern and southern part of a 200-km<sup>2</sup> submarine bank. The uninhabited minor islands Uea, Hatana and Hafliua are situated along the northwestern edge of the submarine bank. There are a number of other small

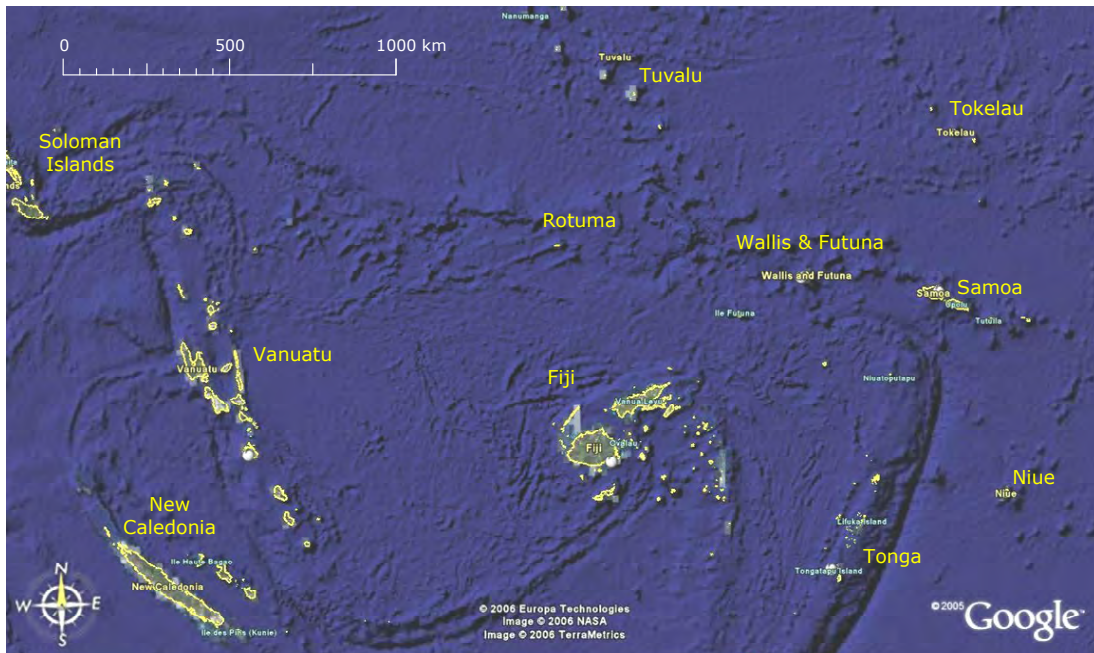

Figure 4.1: Polynesia

islands which are located within the fringing reef of the main island. The reef endows Rotuma with an ample supply of seafood, although environmental problems are taking their toll. During a recent reef survey, Fiu (2003a) found that, despite the reef being in a relatively healthy condition by international standards, “Rotuma like other Pacific Islands is experiencing the brunt of over-exploitation of its marine ecosystem”.





Figure 4.2: Topographical Map of Rotuma. Excerpt of the topographical map published by the Fiji Lands and Survey Department.

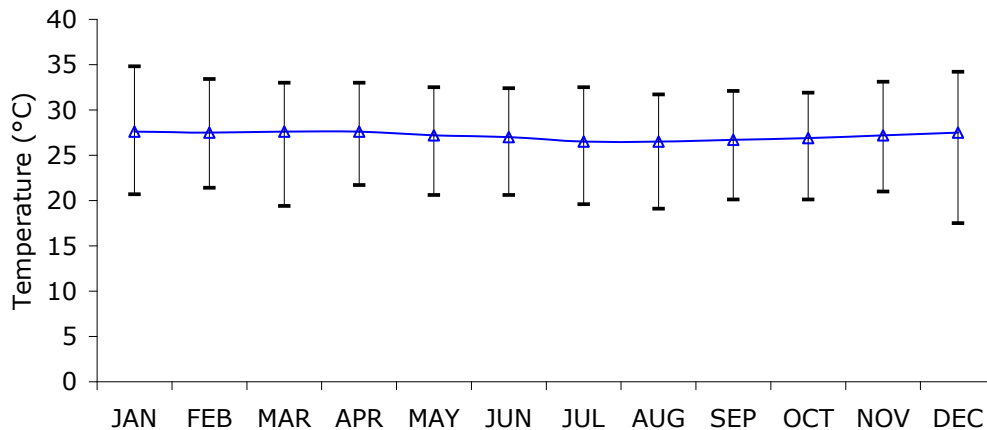

Figure 4.3: Mean average monthly temperatures (1936–2000), and lowest and highest recorded temperatures (1971–2000). Recorded at Rotuma weather station (ID W65000) at Ahau. The underlying data was kindly provided by the Fiji Department of Meteorology.

A topographical map of the island is shown in Figure 4.2. Most of the interior of the island has steep mountainous terrain. There are numerous volcanic cones and craters. Actively decomposing volcanic rock supplies the supports luxurious plant growth. While all settlements are on more or less wide flat areas around the perimeter of the island, the gardens and plantations are distributed all around the interior of the island. The eastern and western parts of the island are joined by a narrow sandy isthmus at Motusa.

## 4.2 Climate

Rotuma lies in the tropics with a hot and humid climate. As shown in Figure 4.3, mean monthly temperatures are fairly stable year-round. Figure 4.3 also shows the lowest and highest temperatures recorded; the total temperature variation is low.

The average rainfall for Rotuma is 3550mm per year<sup>1</sup>, i.e. ten times the rainfall of Christchurch, New Zealand. Although records for the last 95 years show no rainless months, rare dry periods of up to three months in duration have been known to occur (Gill 1971). Monthly average rainfall with minimum and maximum recorded values are shown in Figure 4.4.

<sup>1</sup>This number is based on Fiji Department of Meteorology records over the past ten (TBR) years (1912-2004). Records are from the weather station at Ahau. Personal observations showed that rainfall is fairly variable across the island. For example, Oinafa district often remained dry while it was raining heavily on the Western side of the island.

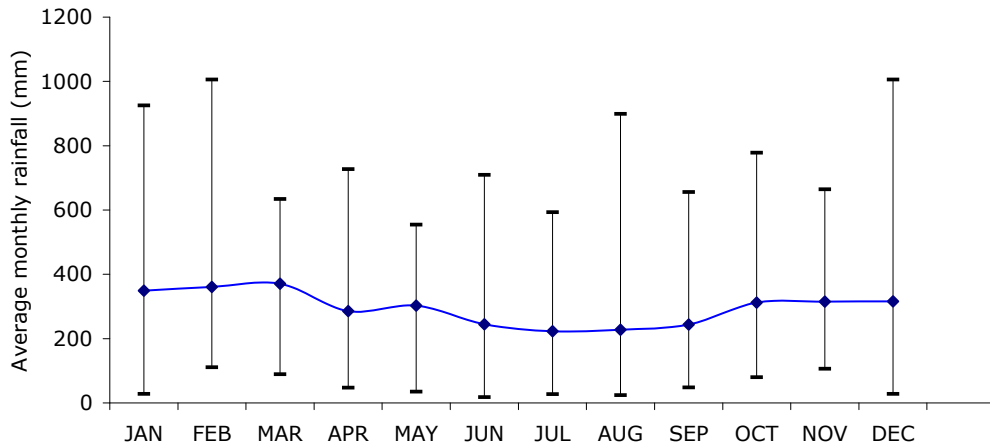

Figure 4.4: Average monthly rainfall with lowest and highest recorded monthly rainfall (1912–2000). Recorded at Rotuma weather station (ID W65000) at Ahau. The underlying data was kindly provided by the Fiji Department of Meteorology.

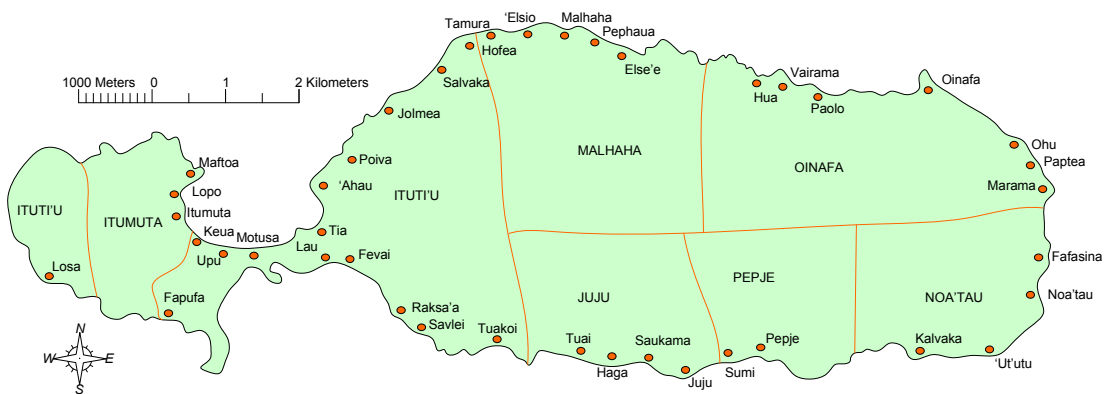
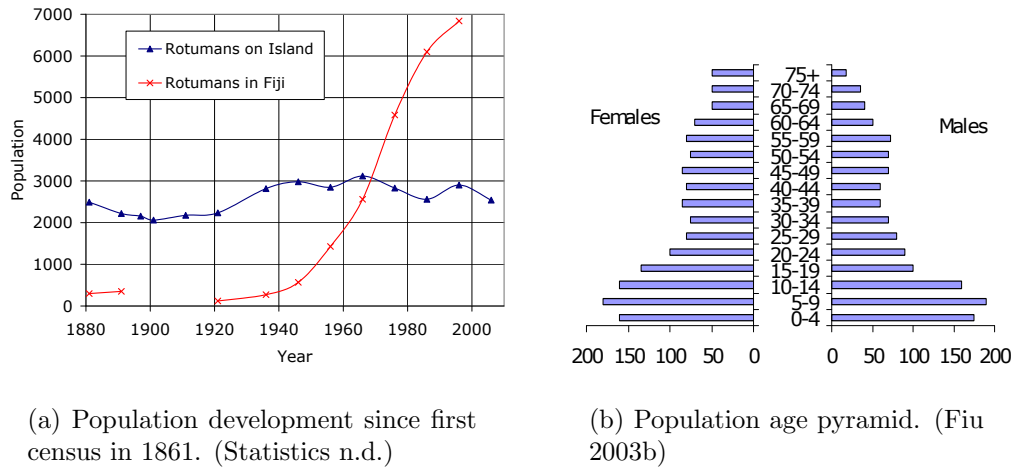

Figure 4.5: The seven districts and 32 main villages on Rotuma

### 4.3 Rotuma's people

Rotuma has a 2500 permanent population, while an estimated 20,000 ethnical Rotumans live in Fiji or oversees (Fiu 2003b). Rotuma is comprised of seven districts with respective district chiefs. The island has 32 main villages which are all located along the coastline (Figure 4.5). According to Eason (1951), Rotuma was first settled by Micronesians. Melanesian influxes occurred before the fourteenth century. During the first Polynesian invasion by Samoans, the original inhabitants of Rotuma were displaced from their coastal settlements and driven inland. In 1660, a group of 300 Polynesians from Tonga invaded and conquered Rotuma. However, they were defeated and killed after ruling the island in tyranny for one generation. The first European visit to Rotuma was in 1791 by the H.M.S. Pandora (Eason 1951). Missionaries started to arrive on Rotuma in the 1840s, but were initially unwelcome. It was only after another 25





(a) Population development since first census in 1861. (Statistics n.d.)

(b) Population age pyramid. (Fiu 2003b)

Figure 4.6: Rotuma population statistics.

years passed until the Catholic and Methodist missions started to make significant inroads. Disputes between Catholics and Methodists led to religious wars and a split among Rotumans. Only in the 1960s, the two churches started to show signs of serious collaboration (Ieli 1991).

Population levels on Rotuma have been relatively stable. Today's population is almost the same as during the first census in 1891. The population development since then is shown in Figure 4.6(a). The recent population decline coincides with an unprecedented rate of emigration of Rotumans to Fiji or other countries. The population pyramid in Figure 4.6(b) shows a major dent for the age groups 20 to 29. Fiu (2003b) attributes this to a great movement of young people to Fiji for further studies or employment, after completing secondary education (form 6) at Rotuma High School. At 47%, the majority of the island population are Methodists. Catholics follow closely with 43%. Minorities include the Seventh Day Adventists (5.9%), Assembly of God (2.1%) and Jehovah's Witnesses (1.6%) (Fiu 2003b).

## 4.4 Daily life on the island

This section gives a brief glimpse at what the daily life on Rotuma looks like. Most people get up very early in the morning, usually well before sunrise. With the exception of the employed, the major part of the male population would take to the bush early on and work in garden and plantations until late morning. The women's main responsibilities are fishing as well as various tasks around the house. After lunch time around midday, temperatures on the island are usually too hot for effective work, and a lot of people are found relaxing in meeting houses

or under Hifau trees<sup>2</sup>. Later in the afternoon people return to work in the bush or plantations.

Dinner is usually prepared before dark in order to make use of the daylight. In the evening, people often informally gather around their homes or meeting houses. In most of the villages, diesel generators would be turned on for two to four hours just after sunset. One of the favorite activities for a lot of people is watching DVDs. Predominantly males often get together to talk and drink kava for hours. This applies in particular to the catholic areas. Methodists are officially discouraged from kava drinking. Kava on Rotuma was traditionally seldom consumed, and kava ceremonies are much more casual than for instance on Fiji. The churches on Rotuma are very active by Western standards. Some people attend services every morning. Being a good Christian is a core value with today's people of Rotuma.

For projects that require several hands, whether this might be to build a house or a wedding preparation, people of the communities are expected to work together. Figure 4.7(a) shows a picture of a group of Rotumans building someone's house as a community activity. Ceremonies such as weddings and funerals take several days. For such important events, people of the community have almost no time for the usual chores such as planting.

## 4.5 Education

With the exception of the Catholic primary school at Sumi, Rotuma's school system is administered by the Fijian government. There are five schools on Rotuma, one high school and four primary schools. The high school and one primary school are located at Malhaha. The remaining three primary schools are distributed evenly around the perimeter of the island.

The primary schools cover four age groups, and the high school six age groups from form 1 to form 6. University entry is acquired with the completion of form 7 in Fiji. School teachers on the island are mostly Rotumans with some Fijians and the occasional European. Students pay a moderate school fee of F\$10 per term for primary schools and F\$20 per term for the high school.

## 4.6 Economic activities

Rotuma's economy unites aspects of a Western capitalist economy and a traditional subsistence economy. The economy is therefore hard to describe in numbers, adding to the fact that there is hardly any recent data available on Rotuma's economy.

---

<sup>2</sup>Hifau (or Dilo) trees grow all around the perimeter of the island. Hifau trees are known for their cooling effect through extensive evaporation of water from the leaves.



(a) House building near Maftoa.



(b) During a funeral ceremony on Rotuma.

Figure 4.7: Community activities on Rotuma.

Although most households are self-reliant on the traditional food crops, an increasing percentage of their dietary requirements comes from imported foods.

The minority of households relies on only one single source of income. In a 2003 survey, Fiu (2003b) investigated the importance of different income sources to households (see Figure 4.8(b)). In the underlying questionnaire, people were prompted to provide their highest source of income. Fixed salaries come predominately from government positions, such as laborers, teachers, administrative and political staff. Commercial fishing activities are limited to the occasional sale of fish within the island. It is unclear what farming encompasses, but there is no real market for crops on the island. Fairly large amounts of vegetables and livestock are exchanged for money with Rotumans resident on Fiji. Copra has been the traditional mainstay of the Rotuman economy, and may still be considered one of the most reliable sources of income to Rotumans. Remittances from relatives in Fiji and overseas play a significant role in Rotuma's income. Although only 15% of the population regard remittances as their primary source of income, the actual sum of money remitted to the island is likely to be significantly more than 15% of Rotuma's cumulative income. Rensel (1993) found that the vast majority of remittances is paid in very small amounts. But the sum of many regular small remittances is dwarfed by the sum of very few specialized remittances, for example contributions to a wedding, funeral, or church events.

Figure 4.8(a) shows the numbers of trading licences issued on Rotuma in 2006. It appears that the number of retail outlets is high for the population, but most outlets are nothing but families selling some basic goods out of their homes. Video rental places are especially successful due to the almost complete lack of television on Rotuma<sup>3</sup>. Other small businesses offer various services and products, from chauffeuring to the home fabrication of mats and handicrafts that are mainly sold to expatriate Rotumans. However, large businesses have not been successful on Rotuma. An example of a failed business on Rotuma is the early 20th century, where two large companies, "Morris Hedstrom" and "Burns Philp" established themselves on Rotuma and handled copra exports and most of the sale of goods on Rotuma. But in 1926 Rotumans boycotted the firms for about six months, buying nothing from the shops and selling no copra (Rotuma-District-Office 1935). Other failed enterprises are the Rotuma Cooperative Association (RCA) and the Raho Cooperative which collapsed in 1993 and 1994. Reasons are multifold, and certainly had to do with mis-management; but the issues are more complex. For example, jealousy and disputes about the distribution of profits were regarded as the cause for the failure of a cruise ship tourism endeavor in the 1970s (Rensel 1993). Generally it is difficult to run businesses in a purely professional way because of kinship obligations: if anyone acquired wealth beyond the average he would be expected to share it with family. But

---

<sup>3</sup>SkyTV has become available on Rotuma very recently, but is too expensive for the average household.

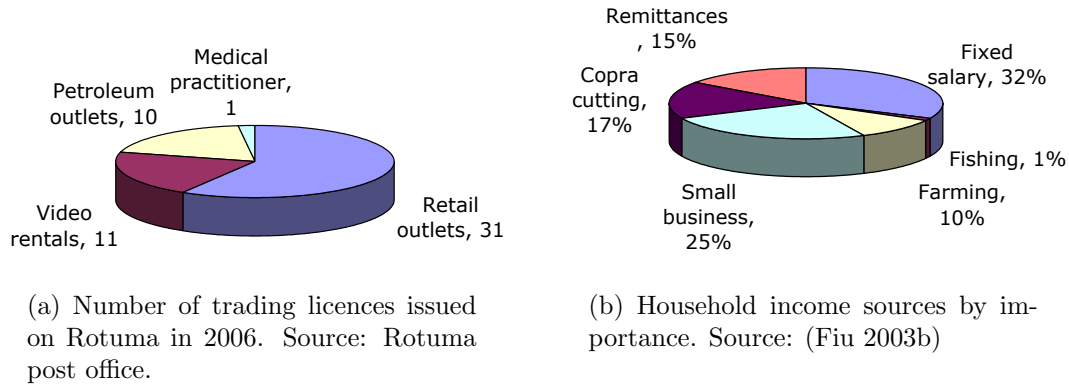

Figure 4.8: Economic activities on Rotuma.

because of Rotuma's small population, virtually everyone is more or less closely related to everyone else. On the other hand, money plays a different role on Rotuma than in a Western country because the value system is different. Fiu's (2003b) extensive community survey found that average household expenditures are roughly equal between the four categories: hanua (community obligations), church, education, and household expenditures, with somewhat less money spent on education than on all other categories, and most money spent on the church.

Having laid out some of the special conditions facing commercial ventures on Rotuma, the following list introduces selected existing businesses:

### **Mamfiri Oils Inc.**

Mamfiri Oils Inc. was founded by Mr. John Bennett, an American married to a Rotuman. John Bennett produces high quality Hifau oils, primarily for the German cosmetics industry. Hifau is a natural resource on Rotuma, and has been traditionally used for medical purposes. Hifau trees are growing all around the perimeter of the island, along the shore. Although Mr. Bennett employs people for certain tasks such as nut-cracking in busy times, his efforts to find anyone for full time employment have been futile. According to Mr. Bennett, people might be interested to work with him for a some time, but would normally get bored with the work before too long. Also, community obligations and the traditional ways of planting and thus providing for the family are, for most Rotumans, a priority over commercial activity. As of the time of writing, Mr. Bennett's enterprise remains a one man operation.

### **The Juju Bakery**

The bakery in Juju was founded approximately 20 years ago by Mr. Andrea, a returning expatriate from Rotuma. Mr. Andrea has been working on commercial



(a) John Bennett, head of Mamfiri Oils Inc., is producing premium quality Hi-fau oil for the cosmetics industry.



(b) Andrea in front of the large electric bread oven at his bakery in Juju.

Figure 4.9: Business on Rotuma I.

tankers and large ships all around the world. This is where he acquired engineering skills that allowed him to import, install, and operate a modern bakery on Rotuma. The bakery equipment was purchased secondhand in the Netherlands. The largest diesel generator on Rotuma, a 60kVA machine is used to drive a 40kW electric oven and other bakery machinery. According to Mr. Andrea, the bakery was running very well and produced a variety of breads, buns, and cakes. However, Mr. Andrea is finding it difficult to find a successor for his enterprise. He himself is getting too old to run the bakery all by himself. However, the bakery shop is still in service, and sells a variety of imported packaged foods such as tinned tuna fish, breakfast crackers, flour and sugar.

### **Bakery at Malhaha**

The bakery at Malhaha appears to be the oldest continuous business on Rotuma. Kafoa Olsen's grand-grand-father came to Rotuma from Norway, married a Rotuman and founded the bakery. Before wheat flour was available on the island, starches of traditional crops were used to bake bread. Kafoa Olsen's bakery may be considered the opposite of Mr. Andrea's bakery. Mr. Olsen does not believe in machinery, and appears to enjoy operating his large wood fired bread ovens. Mr. Olsen spends the mornings baking breads with his two employees, and in the afternoon his son and himself distribute the bread by mopeds all around the island. Breads are sold for F\$0.90 per loaf, and people order the breads in advance. The daily output is roughly 400 loafs, but can more than double on holidays and for special occasions. Mr. Olsen claims that the demand is usually higher than what he can provide. But running the bakery is hard work, and finding labor is difficult. His employees seem to change rather frequently. The bakery is dependent on supplies from Fiji; during the three month period the author spent on the island, the bakery was unable to operate for two weeks, because the supply boat from Fiji was cancelled that month.

### **Sisters Enterprises**

Sisters enterprises is the largest business on Rotuma, operating three small grocery outlets, two of them stocking petroleum products and fuels. Sisters also handles the vast majority of Rotuma's copra exports. Sisters provides a truck which goes around the island every working day to pick up cut-copra. Sisters employs four or so young workers whose job it is to collect the copra and run the two large wood fired copra driers in Oinafa. Dried copra is bagged up and stored in a storage building at the close-by wharf. It is unclear who owns Sisters enterprises, but there is speculation that it is owned by a Chinese business man in Fiji. The author also heard of some casual speculation that "it might be time to kick Sisters out if they get to o successful".





(a) The wood fired bread oven.



(b) Kafoa Olsen (right) and his employed bakers in the baker's shop.

Figure 4.10: Kafoa Olsen's bakery at Malha, possibly the oldest continuous business on Rotuma.



(a) Headquarters of Sisters Enterprises on Rotuma.



(b) Semi-commercial fisherman Whaga on a fishing trip.

Figure 4.11: Businesses on Rotuma II.



### **Jones' Transport services**

Alexio Jones, a returning expatriate tanker captain, is operating one of several small transportation businesses on Rotuma, using two trucks. Mr. Jones has two permanent employees as drivers. There is seldom a shortage for work, but the busiest days are when the monthly supply boat arrives from Fiji. Mr. Jones had big plans for running a larger business on Rotuma for roadwork and a range of earthwork jobs. He even brought in machinery from Fiji. However, the Council of Rotuma did not approve of his plans and asked him to pull out. The exact reasons for this are unclear, perhaps Mr. Jones did not follow the traditional procedures while seeking permission from the council, and the council was therefore offended.

## **4.7 Living Situation**

The layout of a typical house is illustrated in Figure 4.12. A typical Rotuman household has three different buildings for distinct purposes. Usually there is one sleeping house with a lounge and a few separate bedrooms, sometimes a kitchen. At night time, the lounge typically serves as main bedroom, where traditional sleeping mats are put on the floor to sleep. The majority of households have a traditional kitchen as a separate building. The main feature of the traditional kitchen are one or two “koua” pits, i.e. holes in the ground for traditional food preparation, similar to the New Zealand “hangi” type of earth cooking. However, today most cooking is done using kerosene or LPG stoves. While most of the main houses are concrete made, the smaller traditional kitchen buildings are mainly of traditional wooden frame construction with thatched or corrugated iron roofs. As a third building, the toilets are mostly separate units and made from concrete. Traditionally people used the beaches as toilets. Today, the majority of toilets are flush toilets with attached septic tanks. Septic tanks are from homebuilt concrete construction. A hepatitis B outbreak in 1999/2000 indicated that improper septic tanks are contaminating the groundwater and thus the public water supply (Dawe 2001). This is unsurprising, considering that for example septic tanks are the second highest contaminator of water in the USA (Jenkins 2005), a country with high technology standards.

The greatest change in housing styles on Rotuma occurred in the aftermath of hurricane Bebe in 1972, when the New Zealand army came in and helped rebuilding Rotuma in concrete (Rensel 1997). In an interview during the field study in 2006, a Rotuman resident explains the issues around concrete houses: “If you build concrete houses, people say you’re moving up. Concrete houses are good because they look good. ... But they are always hot, concrete houses are hot. Rotuma is a hot place.” When the author inquired about thatched houses he said: “Yes, more comfortable. If it’s hot outside they are cool and if it’s cold they are warm. But we can put thatch on our concrete house. Roofing iron becomes

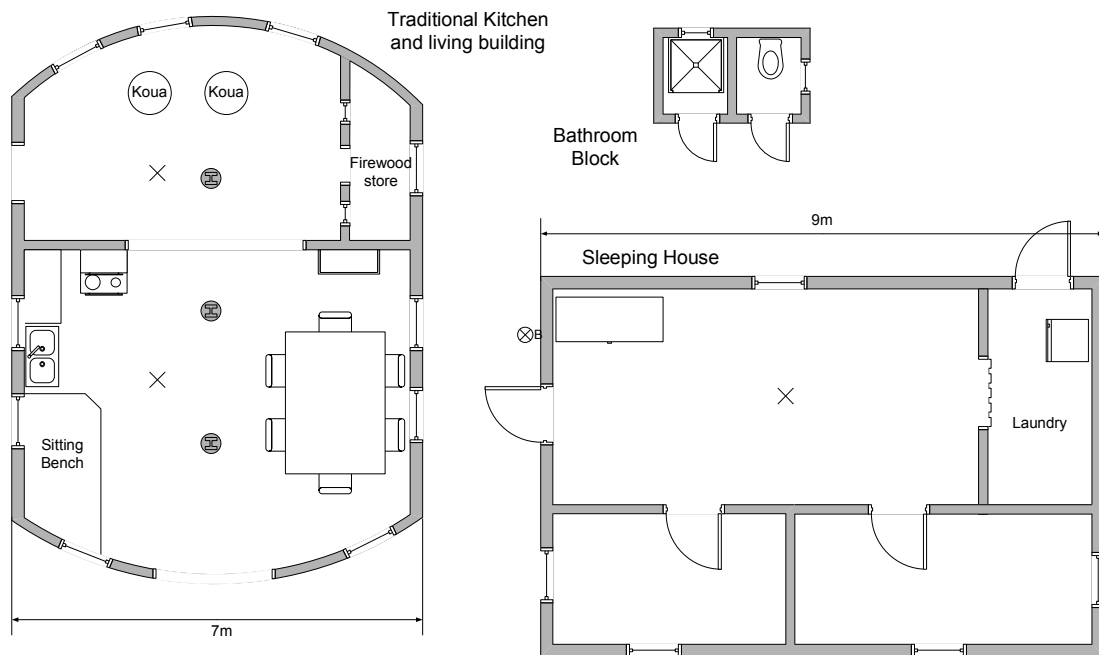

Figure 4.12: Example for buildings layout of a typical household on Rotuma. Typically, the kitchen building is constructed in (modified) traditional style, with a thatched roof and often corrugated iron walls. The sleeping house is more often made with concrete walls and corrugated iron roofs. Central part of the traditional kitchen is the koua pit, a fireplace for traditional earth cooking.



(a) CMB upon arrival at Rotuma.



(b) Twin otter on the Rotuma air field.

Figure 4.13: Two main means of transport to Rotuma.

more and more expensive. It's \$38 a sheet, and one house needs 20 sheets.”

During the field study, temperatures in concrete and thatched houses were recorded over two days and nights. In average, the concrete house was roughly two degrees warmer than the thatched house.

## 4.8 Transportation System

This section is divided into two categories, transport to and from the island, and transport on the island.

### 4.8.1 Transport to the Island

There are two main means of transport to the island: A monthly supply boat and weekly flights, both between Fiji and Rotuma. The “Cagi Ma Ba” or CMB supply boat is a relatively small boat, perhaps 50m long. The CMB is operated by Western Shipping Ltd. of Fiji under government subsidy of F\$1.0m per year. The government subsidizes shipping routes that are classified as “uneconomical”. The CMB carries roughly 50 people comfortably, but up to 200 people are said to travel on her during busy times. Passengers pay between F\$40 and F\$160 for a one way trip to the island, depending on travel class.

The weekly flights are operated by Air Fiji, a small Twin Otter aircraft for roughly eight passengers. The air service varies considerably. During the author's time on the island, the plane called on Rotuma four times a week in one week<sup>4</sup>, but there were other periods of up to four weeks without any plane. Air Fiji

<sup>4</sup>This was the week where government officials from Fiji travelled to Rotuma as part of their election campaign.

offers a spectrum of excuses for delayed or cancelled flights, the primary excuse being that the (unpaved) runway is not dry enough. There is speculation that Air Fiji cancels flights whenever there are not enough passengers to make the flight economical. A one way ticket from Fiji to Rotuma is available at the fixed cost of F\$350.

### 4.8.2 Transport on the island

The villages are linked by a coastal road. Secondary roads through the center of the island are in poor state of repair, and are only used for access to plantations in the interior. What is referred to as coastal road is actually an unpaved sandy track, maintained by the Fiji Public Works Department (PWD). According to current records (2006) of the PWD, the numbers of motor vehicles operating on the island are:

Type	Numbers
Buses, 60 passengers	2
Mini buses	2
Six-wheels, 7tons (road maintenance)	2
Loader (road maintenance)	1
Grader (road maintenance)	1
Tractor (road maintenance)	1
Four wheel trucks, 1.5-3tons	11
Pickup trucks	20
Private cars	2
Motor bikes	81

The Fiji Post office reports lower numbers: roughly 25 light vehicles (including light trucks, pickup trucks and cars) and 45 motorbikes are registered on Rotuma. Perhaps the PWD counts include vehicles that no longer exist. Most owners of cars or trucks offer transport services as a business. Additionally, the Council of Rotuma is operating two buses. Buses go around the island in the morning and afternoon, mainly to pick up school children. Although the island is small, roads are so bad that it takes at least 45 minutes to cover the 16km distance from the eastern to the western end. Paradoxically, one of the heaviest road users appears to be the PWD road maintenance fleet. The PWD employs about 15 workers and operates two heavy trucks and a digger. Wet salty sand is taken from the beaches, unloaded on the road, and sometimes spread out with the grader. Unsurprisingly, cars rust at record rates. The author's bicycle was unusable after three months on Rotuma. Alan Howard (personal communication) observed, that the use of bicycles dramatically declined in the last 30 years. Perhaps, the old roads were more bicycle friendly than the salty sand tracks today.

Small outrigger canoes, which have been historically used as major means of transport around the island, are no longer used for transport purposes.

## 4.9 Judicature

Rotuma has a police station with three staff. The district officer acts as a lawyer. There is a one cell prison at the government station at Ahau. Crime on Rotuma is uncommon but does occur. According to the local police officer, most quarrels are about land boundaries. Most crimes are handled internally.

## 4.10 Health

The rural hospital on Rotuma offers free health care and free medications, paid for by the Fiji government. There are one doctor, a dentist and several nurses. The hospital is able to accept up to eight stationary patients. The biggest health issue on Rotuma at present appears to be diabetes. Polynesians are physically less tolerant to sugar than Europeans, but amounts consumed on Rotuma are comparatively high.

# Chapter 5

## Rotuma Energy Survey

This chapter presents results from energy surveys carried out during the field study in 2006. The results herein exhibit a clear focus on village electricity and electricity to some important governmental agencies. Entities treated in this chapter are summarized in Table 5.1. The survey results are documented subsequent to the survey methodologies in Section 5.1.

### 5.1 Survey Methodology

#### 5.1.1 Domestic Energy Surveys Methodology

Domestic energy surveys were adapted from the general method for energy auditing in Turner (2001). The domestic energy survey focuses on domestic appliances but also includes energy use for cooking. The thermal envelope was not surveyed because there is no domestic air conditioning on the island and at present, Rotumans rely on natural ventilation and few electric fans for cooling. With temperatures seldom dropping below 25°C, and never below 18°C there is no application for space heating on Rotuma.

The survey objective was to establish (a) how energy is used in Rotuman households and (b) the economic impacts from energy use. The survey had to reveal a representative sample for the island.

Rotuma posed some particular challenges to the surveyor: very little information on its energy system and energy use was available in the survey planning phase prior to the trip to the island. The cultural context was hard to assess in advance; for example, it was unclear to what extent a meaningful survey could be carried out in English language, it was unclear which parts of the survey might contain culturally sensitive issues, and it was unknown to what extent direct quantitative questions could be expected to yield sensible results. For example, in Europe most people would be able to say exactly how many horsepower their cars have, while in New Zealand people only know their engines' volumes.

Table 5.1: List of items surveyed in Rotuma and described in this chapter.

Entity	Main survey activities	Sec.
<i>Domestic surveys</i>		
Losa Village	15 residential surveys Generator load curve (1 day)	
Juju Village	11 Generator load curve (1 day)	
Motusa Village	15 residential surveys Generator load curve (2 days)	
All villages	Generator surveys Interviews with generator operators	
<i>Governmental</i>		
Malhaha schools	Detailed energy survey Lighting	
Water Supply Unit	Detailed system surveys	
Rural Hospital	Energy services Solar PV system Generator survey	

In order to address the uncertainties involved, only a tentative survey form was created in New Zealand and approved by the University of Canterbury Human Ethics Committee. On Rotuma, the draft was discussed with culturally knowledgeable residents and put to test with a few trial runs. This way, the survey form could be adapted to Rotuma and optimized in order to gain the best quality results with a minimum hassle to the local people.

The final survey was carried out in the form of structured interviews at the residents' homes. The author attended all interviews personally but hired local translators to assist with communication. The results of a previous survey carried out on the island by trained locals for the Fiji Department of Energy (DoE) showed that, in their case the questions were not clearly understood by either the interviewers or participants.



UoC +++ Rotuma Energy Survey 2006 1/2	
General information	
1	Survey no
2	Village
3	No. of people in household
Electric lighting	
4	Incandescent, 60W
5	Incandescent, 100W
6	Fluorescent, 18W
7	Fluorescent, 36W
Non electric lighting	
8	Kerosene lantern
9	Benzene lamp
Cooking facilities	
10	LPG two burner stove
11	LPG range
12	Kerosene cooker
13	Open fire place
14	Koua pit
UoC +++ Rotuma Energy Survey 2006 2/2	
Energy usage	
15	Benzene (liters/week)
16	Kerosene (liters/week)
17	Candles (qty./week)
18	Batteries (qty./week)
19	Cooking fires (no./week)
20	Koua fires (no./week)
Appliances	
21	Radio
22	TV
23	DVD-player
24	Washing machine
25	Refrigerator
26	Freezer
27	Clothes iron
28	Hot water jug
29	Other 1 (specify)
30	Other 2 (specify)
Comments	
31	

Figure 5.1: Survey form used for domestic energy surveys on Rotuma.

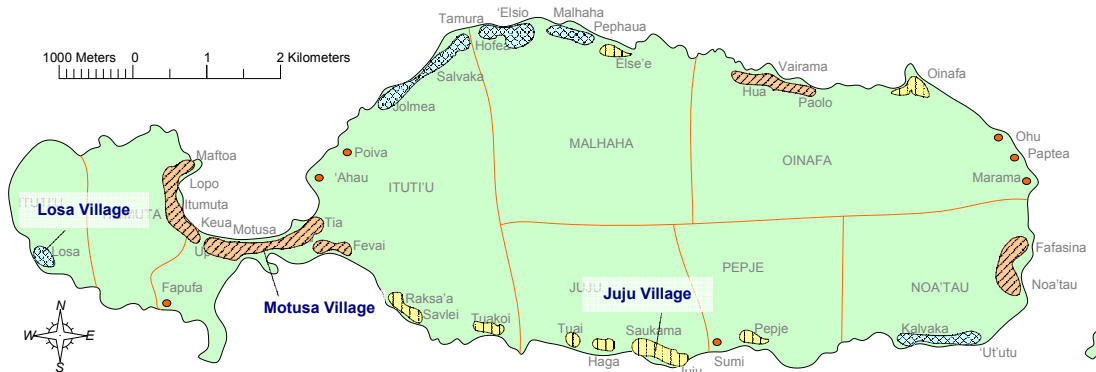

Figure 5.2: Places of domestic energy surveys; Juju, Losa, and Motusa. All other village grids are marked according to their similarity in character to either of the surveyed villages.

The questionnaire form used for this survey is shown in Figure 5.1. For practical reasons, the chosen sampling method was convenience sampling; i.e. the author interviewed whoever was currently available and interested in participating in the survey. This method is theoretically inferior to probability sampling methods because systematic errors can occur (Fink 2006). For example, it would have been possible that a particular category of households had generally been unavailable during times of day when the survey was carried out. However, this problem was mitigated by conducting the surveys at various different times of day. Also, there were very few single cases where people were not interested in participating in the survey.

The scope of the survey was limited by time and resources. In order to make it as effective as possible, the survey was carried out in three different villages, each representing a slightly different degree of energy service levels. An understanding of the relevance of the surveyed places to the rest of the island, all other villages were categorized by their service level by determining which of the three surveyed villages any other villages were most similar to. A map marking the surveyed villages, **Juju**, **Losa**, and **Motusa** is shown in Figure 5.2. All other village grids are marked in the map and pattern-coded according to their respective service level categories. The numbers of individual surveys conducted were 15 for Juju, 11 in Losa, and 15 in Motusa. The survey results are presented in section 5.2.

### 5.1.2 Other Energy Surveys Methodology

Surveys of businesses and institutions were structured by energy auditing standards (e.g. (Turner 2001)). Data about the operation and services provided by the various entities are included as well as independent power supplies where applicable. Survey reports generally provide a description of the facilities, uses, cost analysis, and potential energy savings analysis.

### 5.1.3 Aspirations Survey Methodology

In addition to the energy survey which is, in one form or another part of any energy planning project, an additional survey has been dedicated to understanding people's aspirations. The objective of this survey was (a) to frame the range of personal aspirations and (b) to find out the distribution of distinguishable aspiration levels among the population. After lengthy discussions with people from Rotuma and after some unsuccessful trial runs, the survey sheet in Figure 5.3 was developed and presented to residents. They were asked to identify the one scenario (out of four) they would like best for Rotuma. The sheet describes four scenarios representing four different "future Rotumas". The scenarios span a range of energy service levels from a traditional lifestyle without electricity to a lifestyle of modern Western regions with no electricity limitations but price. While previous versions of the survey sheet, particularly an initial trial run in English language were clearly misunderstood by Rotumans, the final survey sheet was clearly well understood. This was evident from people's responses. After studying the form people started to explain to the author why they preferred one scenario over the others. For example, a young man explained that he liked to reverse electrification because electric appliances did actually make life harder on the island: "Before, we had nothing to worry about, all we needed was provided by the island. Now we have to worry about making money to pay for fuel." A middle aged lady had different ideas: "I would like to be able to buy all appliances I want and we need jobs on Rotuma; that's why I like option 4". The form in Figure 5.3 essentially identifies key aspects of four reference built environments which characterize distinctive energy service levels.

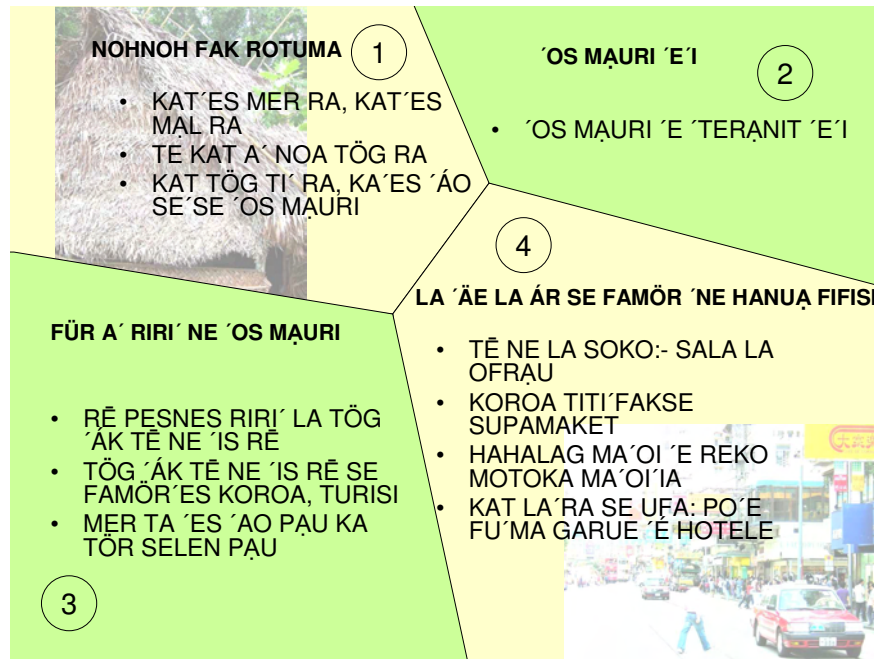

(a) Original version used during the survey in Rotuman.

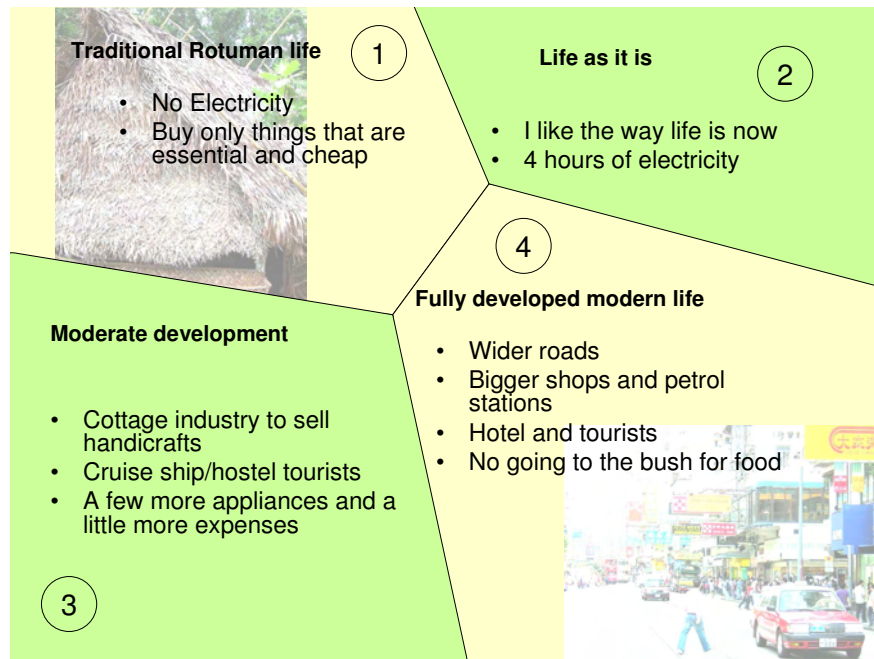

(b) Approximate translation to English.

Figure 5.3: Survey form of aspirations survey.

## 5.2 Domestic Village Energy

As touched upon in Chapter 4, Rotuma's village energy system uses individual community Diesel generators which provide electricity to ten to fifty households each. Electricity is thus available for a few hours per day. Electricity uses are for lighting and other selected appliances. The following sections offer general descriptions of the surveyed villages, overviews of the energy systems and economical aspects and issues.



Figure 5.4: Satellite image of Juju and surroundings. Solnohu Island lies within the reef and can be reached by wading through shallow waters at low tide.

## 5.2.1 Description of Villages

### Juju

The village of Juju is one of three main villages of Juju District. Seen in the satellite image in Figure 5.4, Juju Village is located on a sandy flat on the south coast of Rotuma. To the north, Juju is protected by relatively steep hills, rising up to 213m above sea level. South of Juju lies Solnohu Island. Solnohu Island is separated from the main island by a shallow trench, 100 meters wide. At low tide it is possible to wade to the island. Solnohu Island has been, and to a small extent still is, used for plantations. The hills to the North of Juju are used mostly for plantations for traditional food crops and copra. As in other parts of the island, there are steep and inaccessible areas that are not developed but covered in native bush. Village lands extend roughly to the East-West central road. The farthest plantations are at a walking distance of about 3.5km from the village. Juju village is composed of 3 sub-villages by the names of Islepi, Koheatiu, and Utheta. Additional to these, also included in this survey is Saukama village, 500m West of Juju, and part of Juju's electric village grid. During the prevalent meteorological conditions Juju village enjoys a comfortable breeze; the village is very well exposed to the south-east trade winds. Houses in the village are partly well shaded by coconut palms and other trees, making for a comfortable living climate. Houses are mostly of concrete or stone-work with corrugated iron roofs. Less than a quarter of all houses are thatched. Figure 5.5 shows a fairly typical



Figure 5.5: A typical house in Juju village.

house in Juju. Juju and Saukama have a total population of 171, distributed over a total of 42 households. A number of houses in the village are abandoned and in various stages of decay.

### **Losa**

Losa is perhaps the most isolated village on Rotuma. It is located on a sandy stretch of otherwise rocky south-western coastline in the western part of the island. A satellite image of Losa is shown in Figure 5.6. Losa is connected to the other villages by a hilly road through the interior. The village is exposed to the trade winds and despite the barrier effect of the reef, the beach is exposed to often heavy swells from the west. People from Losa also have the land rights to the the outlying islands of Hatana and Haffiua, both several kilometers offshore. Losa is perhaps one of the more traditional villages on Rotuma with an ostensibly high degree of inter community exchange and cooperation. Losa has fourteen households with a population of roughly 60.

### **Motusa**

Motusa is the largest village on Rotuma. It is located on the flat sandy isthmus connecting the eastern and western parts of the island (see Figure 5.7). Motusa is exposed to both, the northern and southern coast. Maka Bay to the north has very shallow waters, at low tide partly less than one meter in depth and suffers from pollution and invasive algae infestation. Hopmafufu Bay to the south is very different in character; there is no obvious pollution and relatively deep waters with a deep trench provide for water exchange. Before the jetty at Oinafa was built, Motusa was the only anchorage for larger ships. Motusa is still used as an





Figure 5.6: Satellite image of Losa and surroundings.



Figure 5.7: Satellite image of Motusa.



anchorage if Oinafa is inaccessible due to heavy swells. Both coastlines in Motusa suffer from serious erosion. Residents reported that the northern coastline lost a land stripe, more than a meter wide to the sea. Motusa's central position makes it an important economic center and hosts several small retail outlets and one of the two 'petrol stations' no Rotuma. Motusa has approximately 67 households and is home to about 270 people.

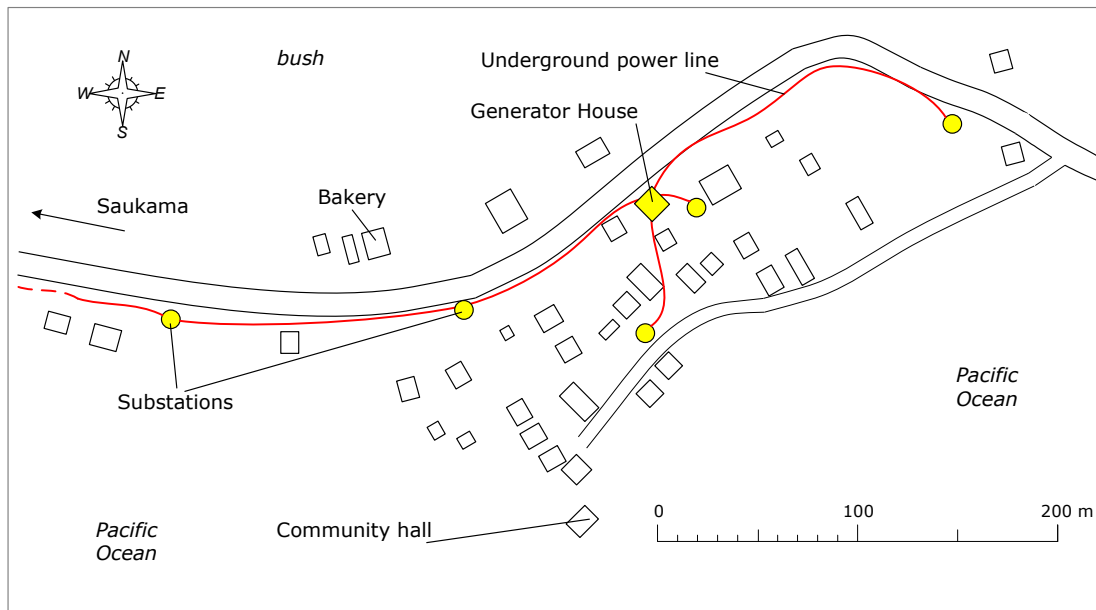

Figure 5.8: Map of the electricity grid in Juju.

## 5.2.2 Electricity Systems

### Juju

Juju village and Saukama are served by the one village owned and operated Diesel generator, located in Islepi. The 6kVA single phase Lister generator (Figure 5.9(a)) has been installed by the Rural Electrification Unit of Fiji's Department of Energy, in 1983. The layout of the mini-grid is shown in Figure 5.8. The generator connects to seven substations (see Figure 5.9(b)) which provide the individual household connections. The generator is nominally running for four hours per day, from sundown around six pm until ten 'o clock at night. As anywhere else on Rotuma, the grid is based on 6mm<sup>2</sup> 3-wire underground cabling with a nominal voltage of 240V.

Apart from the community hall in Saukama, the grid does not serve any other communal or commercial facilities. The only business enterprises, a bakery in Juju village<sup>1</sup> and a shop in Saukama have their own independent diesel generators. Of all 42 households in the area, a total of 32 households are presently connected to the village grid. The ten remaining households decided against electricity. When the author inquired about it, one returning expatriate couple remarked: "electricity just for lights is a waste of our time. We would use it if we were able to run other appliances like refrigerator and washing machine".

Juju's 6kVA generator is reported to normally consume five liters of diesel fuel per day (1.25l/hour). However, at the time of the survey the generator used

<sup>1</sup>The bakery is treated separately in section 4.6



(a) Diesel generator in Juju.



(b) Electricity grid substation in Juju.

Figure 5.9: The Juju village energy system.

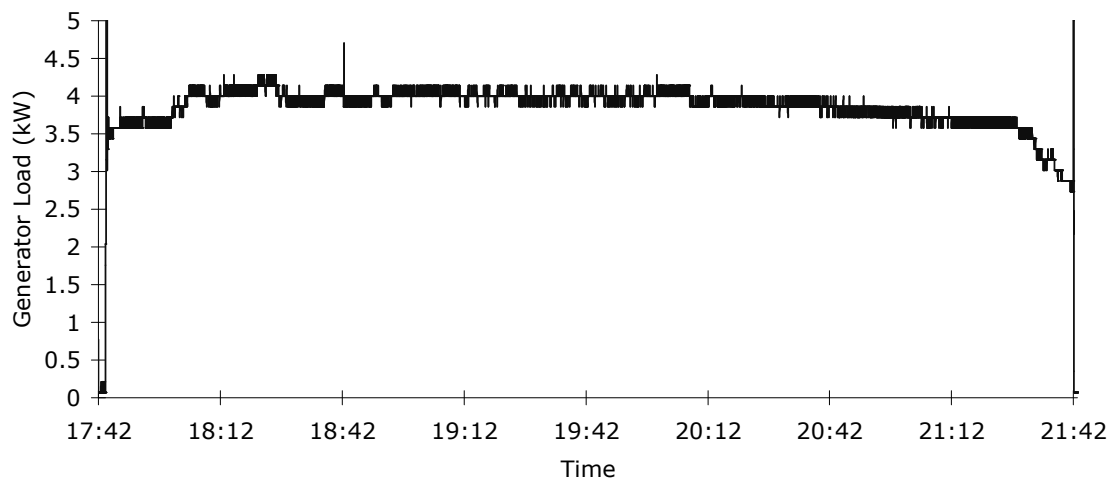

Figure 5.10: Diesel generator load curve in Juju, recorded on May 10, 2006

six liters per day because of a leak in the fuel pipe. The leak had been there for several months but no one in the community had fixed it.

The generator in Juju has been operating relatively reliably. Within the last five years, the generator in Juju was out of service for about two months because of a coupling problem.

A load curve has been recoded at the Losa generator for one night, and is shown in Figure 5.10. The curve presents a fairly average day. Because the daily fuel use is reported to be fairly constant, it is assumed that the load curve shows relatively little variation from day to day. The generator is running close to its capacity for most of the time, with slight drop offs for the first and last 30 minutes.

### **Losa**

The village of Losa was only electrified in 2004. A 3 phase, 15kVA generator was installed by the DoE. The generator is significantly oversized for the loads in Losa, and was also incorrectly installed; one of three phases is disconnected leaving the generator in unbalanced operation. The two connected phases serve different parts of the village. The electricity grid is mapped out in Figure 5.11. Nominally, the generator is operated for three hours in the evenings, but in reality this closer to half this time. The grid serves 14 households, one church and a small community hall. The daily fuel consumption is reported to be 5 liters. The Losa generator had a major break down only a few months after its inauguration: the alternator burnt out and electricity was unavailable for many months until sufficient funds could be raised to pay for the repair in Fiji. It is unclear why this happened, but there are two obvious factors that might have played a role: the generator is operating at less than 20% of its rated capacity and with one phase being disconnected, the generator phases are out of balance. A load curve has been recorded for the Losa generator for one night (see Figure 5.11). Apart from a slight downward trend towards 21:00 there is little variation.

### **Motusa**

With a capacity of 40kVa Motusa employs the largest village generator on Rotuma (see Figure 5.13). The generator was installed in 2004 by the DoE. A map of the Motusa grid is shown in Figure 5.14. The grid was supposed to have three phases throughout, however, the installation was shortcut<sup>2</sup> and it appears that most of the grid is now a single phase installation. The 3 phase generator connection

---

<sup>2</sup>Some Rotumans explained that workers of the DoE received cables for a complete 3 phase installation, but installed the grid as single phase in order to save cables and sell the copper to scrap metal yards in Fiji. In order to do this, DoE workers allegedly burn the plastic insulation off, and carry the cables back to Fiji in copra bags.

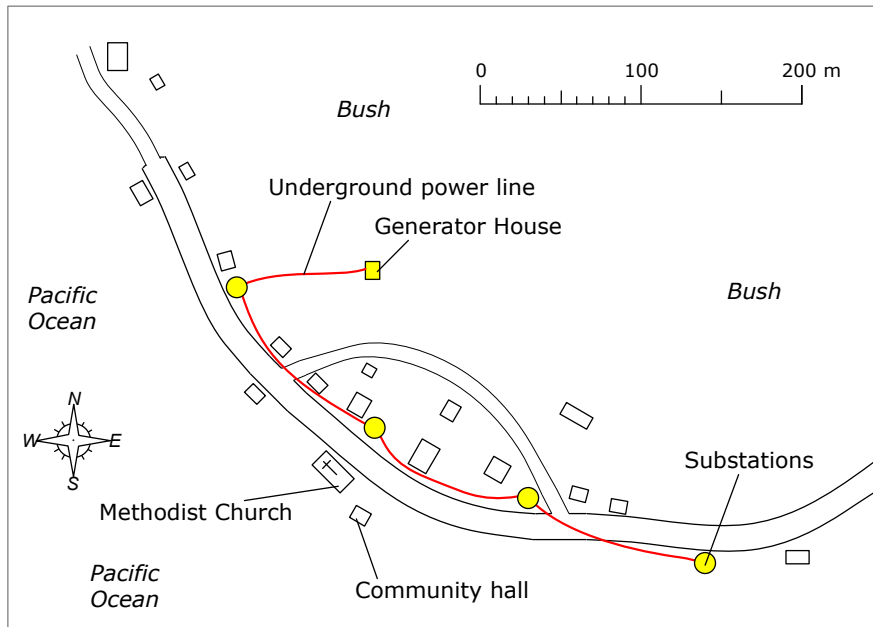

Figure 5.11: Map of the electricity grid in Losa.

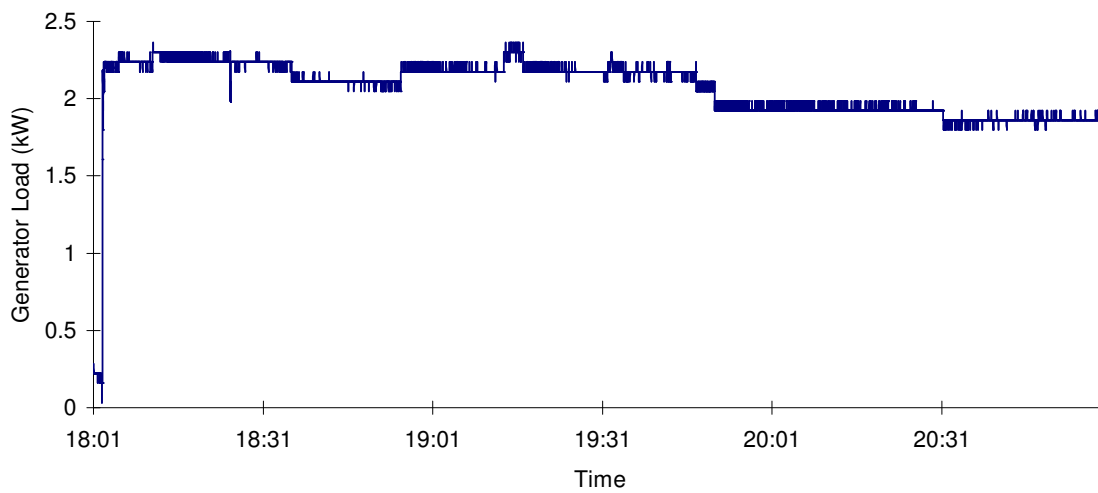

Figure 5.12: Diesel Generator load curve, recorded on May 28, 2006



(a) Generator.

(b) Control panel.

Figure 5.13: Motusa village generator.

is faulty, with two phases carrying more than 90% of the total load. The three phases serve single phase sub grids to physically different parts of the village.

Electricity is provided for six hours per day, in two blocks from 4:30 to 6:30, and from 6:00 to 10:00. While initially 67 households were connected to the Motusa grid, this number had dropped to 51 by 2006. Also connected are two large churches, a primary school and a large community hall. The daily fuel consumption averages 18 l per day. A system load curve is presented in Figure 5.15. The loadcurve is significantly different to the loadcurves of Juju and Losa. While there appears to be a fairly constant base load around 11kW, there are some sharp peaks of different durations. The difference between the Motusa and the other loadcurves reflects different types of appliances in use.

### Other Villages

The electricity systems of the above and all other villages on Rotuma are summarized in Table 5.2. In the field marked 'Cat.', the table marks which of the three surveyed village grids the particular grid is most similar to. Herein, 'j' stands for Juju, 'l' for Losa, and 'm' for Motusa. All village grids listed were installed by the DoE. Daily hours of operation are to be understood as nominal values that are not always achieved. For example, Itumuta nominally provides four hours of electricity per night, however, during the author's stay in this district the generator was only working for about half of the nights, and even then only for 2 hours per night. This discrepancy also partly explains the mismatch between nominal fuel consumption and monthly electricity fees in some villages. Electricity fees

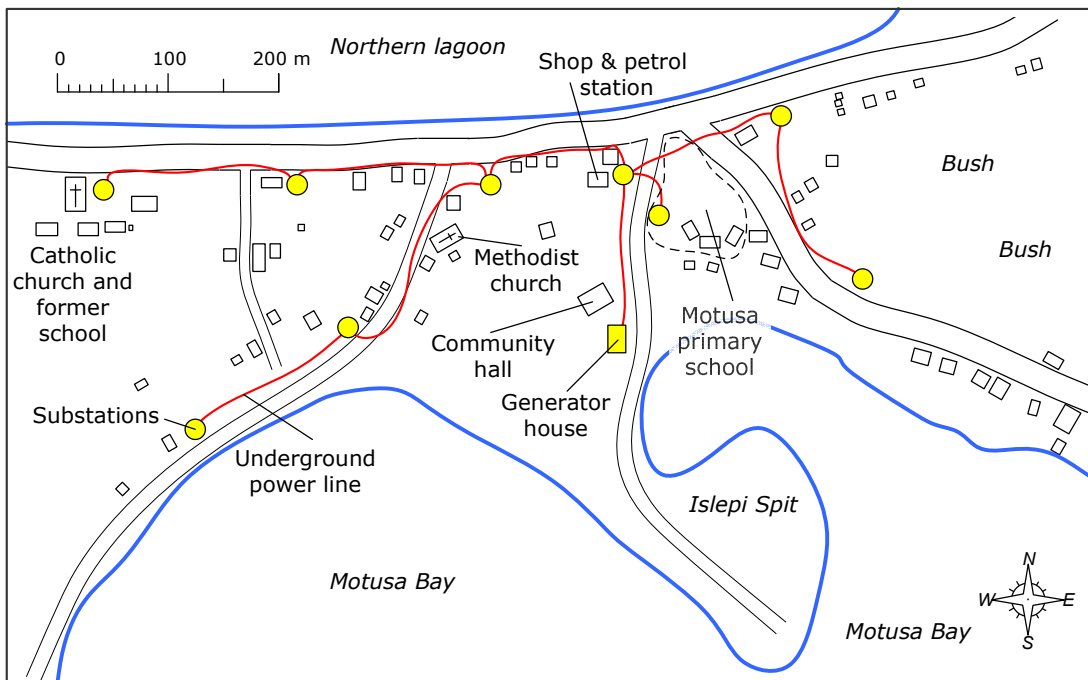

Figure 5.14: Map of the electricity grid in Motusa. Motusa features the largest village grid on Rotuma.

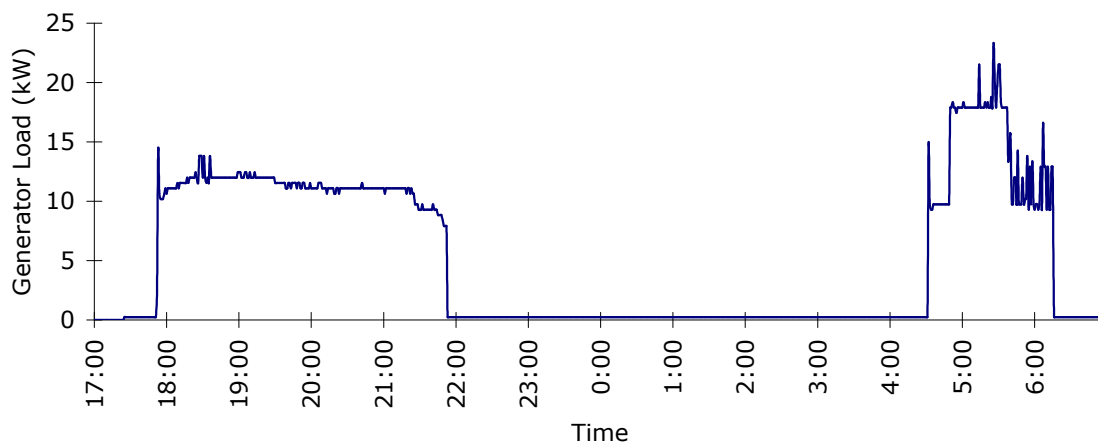

Figure 5.15: Diesel Generator load curve, recorded on June, 8, 2006

are discussed in more detail in Section 5.2.4.



Table 5.2: Summary data of all village grids on Rotuma.

District	Village	Households		Cat.	Generators set			Electricity service	
		Total	Electrified		Capacity	Year	Daily fuel use	Hours/day	Monthly fee
Itutiu	Hapmak	38	30	l	17.50kVA	1998	10 l	4	\$12.00
	Motusa	67	51	m	40.00kVA	2004	18 l	6	\$42.00 <sup>a</sup>
	Lau	12	12	l	17.00kVA	1991	4 l	3	\$11.00
	Losa	14	14	l	15.00kVA	2004	5 l	3	\$10.00
	Savlei	31	30	j	25.00kVA	2002	7 l	4	\$15.00 <sup>b</sup>
	Tuakoi	24	23	j	16.00kVA	2004	6 l	0	\$20.00
	Malhaha	Elsio	12	12	l	5.00kVA	2005	6 l	3
Oinafa	Pephaua	12	11	l	10.00kVA	1995	7 l	4	\$30.00
	Elsee	21	20	j	13.00kVA	1980	10 l	3	\$22.00
	Lopta	39	38	m	20.00kVA	2002	10 l	5	\$19.00
Noatau	Oinafa <sup>c</sup>	17	0	j	5.50kVA	1982	-	-	-
	Maragtteu	46	38	m	27.00kVA	2003	17 l	6	\$20 <sup>d</sup>
	Kalvaka	28	22	l	16.00kVA	2004	12 l	6	\$10.00
Pepjei	Uanheta <sup>c</sup>	15	0	j	15.00kVA	1985	-	-	-
Juju	Tuai <sup>e</sup>	7	9	j	7.00kVA	1985	-	-	-
	Haga	15	13	j	16.00kVA	2005	7 l	4	\$13
	Juju & Saukana	42	32	j	6.00kVA	1984	6 l	4	\$11.50
Itumuta	Maftoa	33	30	m	10.00kVA	2003	6 l	4	\$15.00

<sup>a</sup>Electricity in Motusa is charged by kWh units. The monthly base price, incl. 15kWh is \$42.00, or \$12.00 + 3 Tahroro. Additional kWh units are charged at \$0.20/kWh

<sup>b</sup>Price allows up to 2 lights, ea. extra light and extra power point adds \$1 to the monthly bill.

<sup>c</sup>Generator decommissioned.

<sup>d</sup>Price is reduced to \$16 if only 2 lights are run, the 3 school teachers pay \$40 ea., and the chief \$50.

<sup>e</sup>Generator temporarily out of service.

### 5.2.3 Electricity Use

Having discussed how electric power is generated on Rotuma, this section is about the electricity services delivered. Figures 5.16, 5.17, 5.18 show the appliance penetration data for the villages of Juju, Losa, and Motusa. The graphs also include some non-electric appliances. The given penetration numbers do not refer to appliance counts, but reveal the fraction of households employing any type of appliance. For example, 87% penetration of electric lighting means that 87% of all households are using electric lighting. It is striking that electric light is the most widespread electricity use on the island. Every household connected to a village grid uses electric lights. On average, electrified households have 3.5 luminaires installed. At 85%, most lights are 2-foot fluorescent tube lights, 8% are 4-foot tubes, and 7% incandescent light bulbs. The prevalence of 2-foot tube lights traces back to the fact that these are the default luminaires that DoE installed in every household upon inception of new village grids. But being stocked in most shops, the two-foot tubes are also the lights that are easiest to come by on Rotuma. Finding any other lights or light bulbs can be tricky. Stereos on Rotuma appear to be favored presents from overseas relatives, but are in fact not used very much.

The category ‘Radio’ included stereos that are occasionally found on the island. Most stereos were found in households which also have TVs, in which case the TV set would run all night making the stereo redundant. More use than stereos find small battery powered radios or radio/CD player combinations.

TVs are almost always used in combination with DVD players. Rotuma used to be cut-off from any TV reception. Only recently SkyFiji began to offer a satellite service for Rotuma, but this service is expensive and only engaged by a hand full of households on the entire island. In contrast, DVD rental shops are widespread and highly popular. Although, on average only 37% of households own TVs, effectively every Rotuman has access to it: Watching movies on Rotuma has become a social activity. Wherever movies are watched, people would collect and watch them communally. In such cases, it would be against Rotuman custom to deny anyone to join in. However, TVs are frowned upon by school teachers. The story of a teacher at Sumi Primary School speaks for itself: “I had a very good student once who suddenly significantly dropped in performance and failed many exams; when I talked with her parents I found out that they had acquired a TV which was now running every night... A few months later the same student started to produce excellent marks again. When I went back to her village to see what had happened, I found that the village generator had broken down.” This might be an extreme example, but the issue is widespread. Students living near the author’s host family affirmed that it can be very difficult to do the homework in the evening while the TV is running loudly next door. Considering that a common argument for electricity is to provide reliable lighting for students to do their homework at night, suffice to say, over this issue electricity becomes a

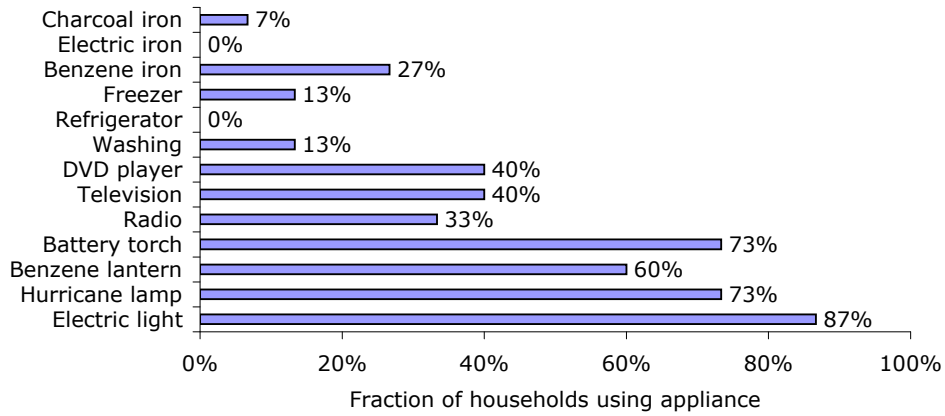

Figure 5.16: Appliance ownership in Juju village.

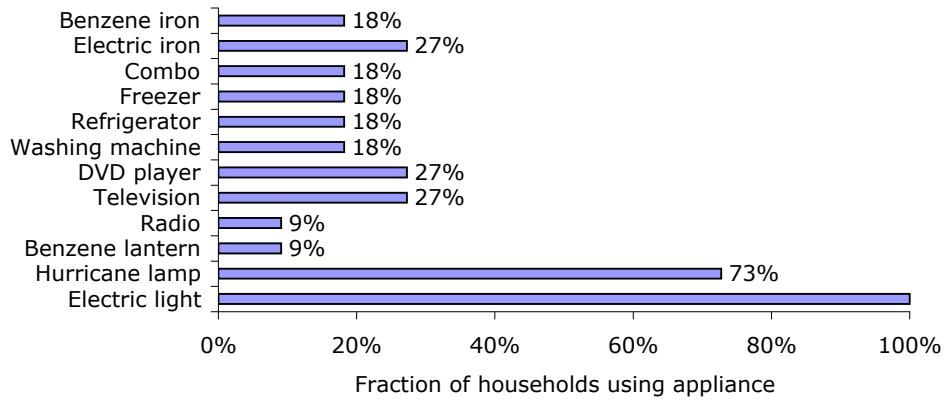

Figure 5.17: Appliance ownership in Losa village.

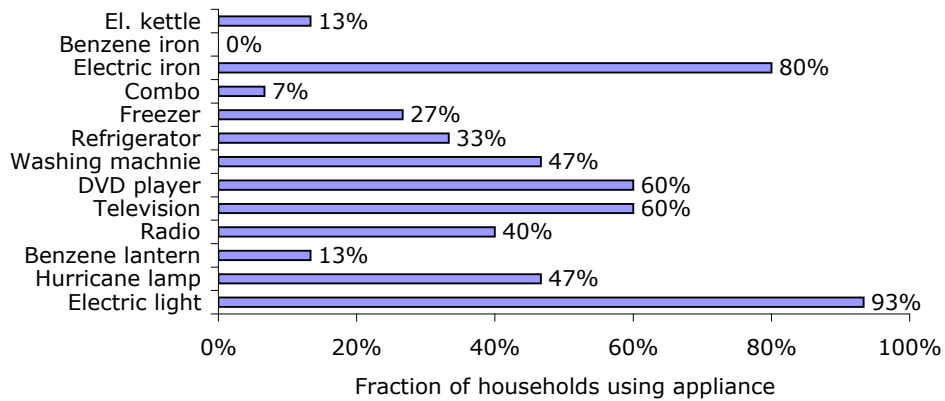

Figure 5.18: Appliance ownership in Motusa.

double-edged sword. Another teacher from Savlei told me: “I used to be in favor of electricity for the sake of light for studying, but now that we see the effects of television I’m not sure anymore.” If electricity is not available, the most common alternative light source for students are kerosene hurricane lanterns.

While the use of the above appliances does not underly any restrictions in either village, the use of other electric appliances is informally regulated to varying degrees in Juju and Losa. Such restrictions are typically put in place as soon as a generator reaches its capacity or is overloaded. The most commonly restricted appliances are electric clothes irons because of their high power use (these are completely banned in many villages). Most irons inspected on Rotuma were 1000W or 1200W models. Small generators that are already operating near capacity, as is the case in Juju would immediately react to such high power appliances with great voltage instabilities. The traditional alternative to electric cloth irons are the somewhat more inconvenient charcoal irons which use charcoal that is available virtually everywhere on Rotuma. The more modern alternative are benzene irons. The other extreme is Motusa, where the grossly oversized generator encouraged people to employ more appliances in order to make use of the capacity. Particularly striking is the high penetration of electric cloth irons in Motusa. A dirty but wide-spread alternative are gasoline irons; less popular are charcoal irons.

While very few freezers and washing machines exist in Juju, no further ones can be acquired even though some people would like to get some. Although on island wide average about 20% of households have washing machines, these were observed to find only occasional use. There are several reasons for this: The water supply on the island is intermittent while in most villages the water hours don’t match electricity hours. On a general note, doing laundry in the evening (when most generators would be running) is also not recommended; because of the tropical climate, washing would turn fairly smelly by the morning after hanging it out wet for only one night. Without being able to resort to data to back up this claim, the author observed that households with washing machines simply produce more laundry than others, thus equalizing much of the saved time.

Refrigerators and freezers have limited usefulness on Rotuma, partly because a few hours of electricity per day are not even sufficient to cool them down to operating temperature. During the survey, measurements on some particular fridges showed that four hours of electricity were just enough to cool the contents of a fully loaded refrigerator by a temperature difference of 10°C.

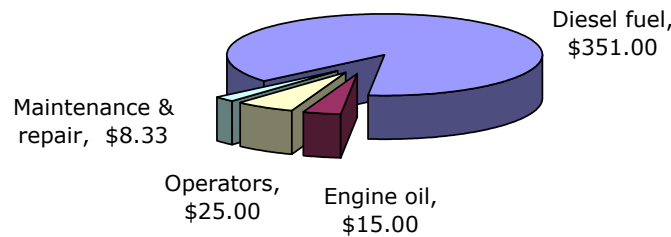

Figure 5.19: Monthly O&M costs for village generator in Juju.

#### 5.2.4 Electricity Economics

This section takes a closer look at how the village energy systems are financed. There are two sides to this: the initial capital investment for installing generator and grid on one hand and the operating cost on the other. All village generators on Rotuma were installed under the DoE's rural electrification scheme. As explained in (Matakiviti and Pham 2003), the DoE subsidizes new rural generator installations and provides for 90% of the initial cost. Generators installed prior to 1996 remained DoE property and thus the DoE remained liable for generator repairs. The scheme was then modified; ownership and thus maintenance responsibility of newly installed generators is now transferred to the communities after three years of operation.

Even the remaining 10% of the cost for new generator installations was often substantial, in particular in the cases where the DoE sold the villages on grossly oversized generators. For example, the recent Motusa and Noa'tau generator and grid installation left the communities with bills in excess of F\$50,000. In both cases, these amounts were raised by relatives of village members in Fiji. As the rather typical example of Juju in Figure 5.19 shows, roughly 90% of the operating and maintenance costs are vested in the purchase of diesel fuel. While shown in the graph as money payment, the two generator operators are actually reimbursed by not paying for their electricity. Regular maintenance costs were estimated, because these costs are not included in monthly fees but money is usually raised after a problem arises.

Fuel prices on Rotuma are high: at the time of survey, diesel retailed for F\$1.85 per liter (this compares to F\$1.65 in Fiji), kerosene for F\$1.65, and cooking gas for F\$54.00 per refilled bottle (F\$5/kg).

Monthly electricity fees per household are shown in the generator list in Table 5.2. But there are different schemes of paying for electricity on Rotuma. The simplest way is that fuel costs are shared directly by participating households. All villages employ a flat rate for every electricity connection, and some villages charge extra rates for high users. For example in Savlei a monthly \$15 is charged to every household which includes two lights, and an additional \$1 is added for every additional power point or additional light fixture.

The only villages where kWh units are metered and recorded is Motusa. Mo-

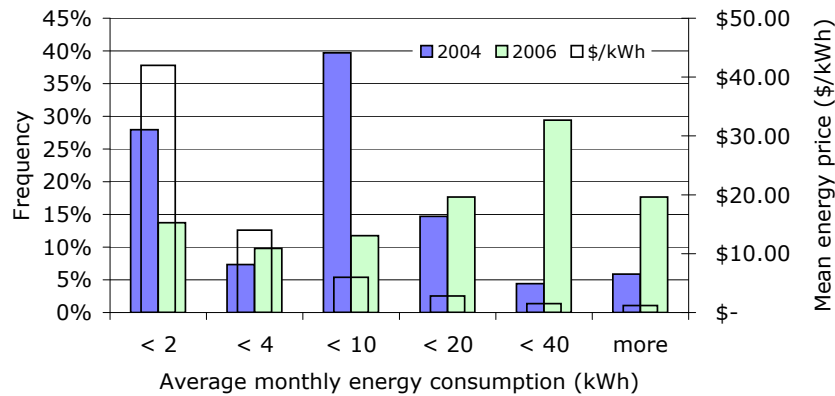
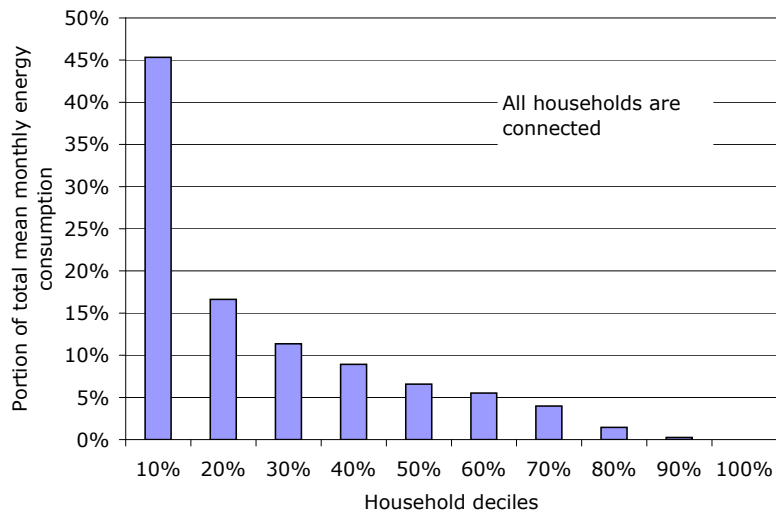
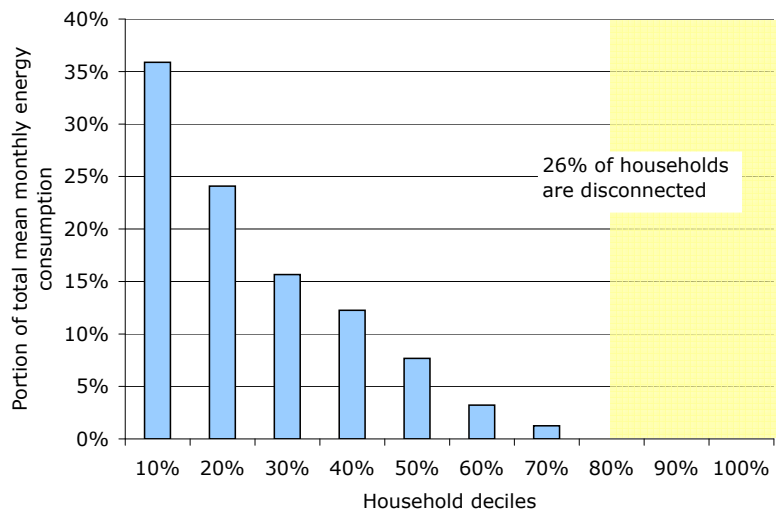

Figure 5.20: Distribution of electricity consumption in Motusa for the years 2004 and 2006; also shown is the average normalized electricity price per bin.

tusa is also the place with the highest electricity prices on Rotuma. In Motusa, every connected household pays a \$42 flat rate including the first 15 kilowatt hours, and \$0.20 for every additional kilowatt hour. This system creates an enormous difference in specific energy costs. Figure 5.20 shows the distribution of households over different energy usage bins for the years 2004 and 2006. The average energy cost in \$ per kWh for each bin is overlaid this graph. The graph shows how electricity consumption has significantly increased, most probably in part because of the given disadvantages for low energy users. Figure 5.21 shows the distribution of energy consumption over deciles of households for 2004 and 2006. The graphs show that there has been a trend towards higher energy consumption and towards a less concentrated distribution of energy use. However, high energy costs made electricity unaffordable for 26% of the population within 2 years. The electricity records showed that most of the drop outs were low electricity users. Discussions with residents and the generator operators suggested that the high fuel bill for the Motusa generator is a very big problem, and the operator is aware that the payment scheme is problematic. While Motusa is perhaps an extreme example, similar issues of grave mismatches of fees and service obtained apply to all villages on Rotuma and there is no payment scheme that adequately reflects how much electricity is used.



(a) November–December 2004.



(b) March–May 2006.

Figure 5.21: Distribution of electric energy consumption in Motusa. The data is based on monthly kWh readings for two months and three months periods in 2004 and 2006, respectively.

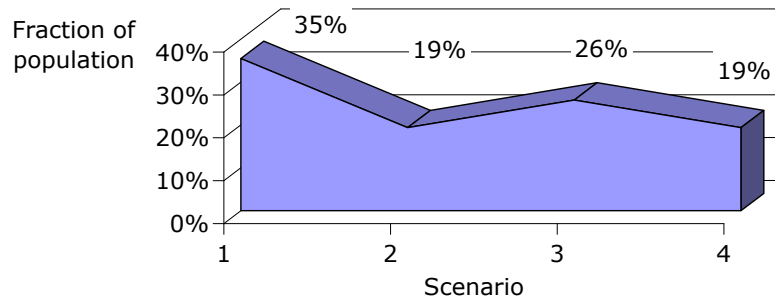

Figure 5.22: Results of aspirations survey. The results are based on insufficient data, but give an indication.

### 5.2.5 Aspirations Survey

The survey was carried out in the villages of Motusa and Losa where a total of 31 people (randomly selected) of all age groups were interviewed. Results are depicted in Figure 5.22. While the number of surveys is too low to be representative for the population, a preliminary conclusions is that there is no clear bias towards any of the four scenarios, all four options are desirable by a significant portion of the population. The aspirations survey is used in the risk analysis in Chapter 7 by converting the frequencies to probabilities that people would be opposed to either of the energy service levels. For this sake, it is assumed that people in favor of service level X would be opposed to any development that is more than one level apart from service level X. For example, it is assumed that people in favor of level 2 would find levels 1 and 3 acceptable, but would be opposed to level 4. In this way it can be determined what percentage of the population would be opposed to either level.





(a) View of campus from SW

(b) Traditional classrooms in the north east corner of campus

Figure 5.23: Malhaha High School

## 5.3 Government Institutions

### 5.3.1 Malhaha Primary and High School

Malhaha Primary and High Schools are both located on the same compound on the northern coast of Rotuma (see Figure 5.23). While the two schools have separate administrations, some resources, and in particular the electricity supply are shared. The primary school covers four school years and the high school six. While the primary school is one of four on Rotuma, Malhaha poses the only high school. There are 12 full time teachers including the school principal at the high school and four teachers at the primary school. The primary school has about 80 students in total and the high school 350. Subtracting a number of drop outs roughly 50 high school students graduate every year. At present, there are 13 classes of 25 to 30 students per class at the high school and four classes at the primary school.

The campus layout is shown in Figure 5.24. The majority of buildings of both schools is located in one row, parallel to the north shore. Those buildings get some shade from large Hifau trees to the north. On most days, there is a comfortable breeze coming from the sea. Seven classrooms are located along the Eastern side of campus. Compared to the northern class rooms, these get less air movement but slightly better shade, because some trees are located very close by. All but two class rooms are of concrete construction with louvered windows, (partly broken) hanging ceilings, and corrugated iron roofs (Figure 5.23(a)). Two classrooms are more or less traditional Rotuman buildings with pole and thatch construction (Figure 5.23(b)). Electricity is provided to both schools by means of the high school's government funded Diesel generator, located opposite the main road. Generator run hours are determined by fuel availability and lighting



Figure 5.24: Malhaha Primary and High Schools



(a) FG Wilson Generator set.



(b) The power house.

Figure 5.25: Diesel generator of Malhaha High School.

Table 5.3: Malhaha generator specification

Manufacturer	FG Wilson, UK
Model	P22
Year	1997
Rated power	22kVA
	$0.8\cos\phi$
Voltage	415/240V
Phases	3
Actual connection of load	L1-N
Disconnected phases	L2, L3

requirements (rainy days). Hours are reported to average 3.5 days a week at 7 hours a day. However, interviews with students suggest that this reported value is more dream than reality. In reality, the generator is operated for a few hours per week should the government have sent fuel. Personal conversations with teachers in different parts of Fiji revealed that the government's fuel provisions to schools are erratic at best.

The high school's diesel generator, a 22kVA Deutz is shown in Figure 5.25, and specifications are given in Table 5.3.

A list of all electric devices on campus is presented in Tables 5.4 for the high school and 5.5 for the primary school. Locations in the tables refer to the campus map in Figure 5.24. Operating hours are simply marked as "on" if equipment is always on if electricity is available. As the tables clearly indicate, lights make for the most important load on the system. Other than lights, there is one freezer/refrigerator unit, one semi electric stencil copier and one photocopying machine. The brand new photocopier is yet packed up and unused. The library also has two ceiling fans and a number of computers. However, at present, all computers are broken down and unused. The computers were donated to Rotuma by the ANZ bank in Fiji. The author observed such donations of unusable computers to several schools around Fiji, definitely a questionable way to dispose of electronic rubbish. Two teachers' quarters (three additional quarters are in dilapidated state and now unoccupied) also count as part of the high school, and feature a number of lights as their only electric loads.

Assuming a transmission efficiency of 90%, the loads of primary and high school combined amount to 2.9kW and a maximum peak load of approximately 5kW. Thus, the generator is 350% to large for the given loads, resulting in poor fuel efficiency (at least doubling consumption) and long term damaging mode of operation of the generator. Additional damage is done to the generator since all of the load is drawn from only one phase of the 3 phase generator. In fact, the grid installation does not provide for 3 phase wiring. Thus, the school would be

Table 5.4: Appliance list survey - Malhaha High School

Room	Appliance	Power	Qty.	Hours per day <sup>a</sup>	Illuminance (lux) <sup>b</sup>	
					Min	Max
R 1	Light	36 W	1	on	140	3000
R 2	Light	36 W	1	nc		
R 3	Light	18 W	2	on	300	1400
R 4	Light	18 W	2	on	280	650
R 5	Light	18 W	2	on	180	400
R 6	Light	18 W	2	on	80	200
R 7	Light	18 W	3	on	140	240
R 8	Light	18 W	3	on	62	120
R 9	Light	18 W	3	on	100	300
	Fridge	130 W	1	on		
R 10	Light	36 W	1	nc	300	4400
R 11	Light	36 W	1	on	140	2400
R 12	Light	36 W	1	on	80	2500
R 13	Light	36 W	1	nc	50	300
R 14	Light	36 W	1	nc	60	680
R 15	Light	36 W	1	on	100	580
R 16	Light	18 W	1	on	5	30
R 17	Light	18 W	1	on	12	100
Veranda	Light	18 W	2	on		
Science	Light	36 W	2	on	70	300
Library	Light	36 W	15	on	102	160
	Fan	120 W	2	on		
	Fax	10 W	1	on		
	PC	200 W	5	nc		
Admin	Light	18 W	3	on		
	Copier <sup>c</sup>	1100 W	1	nc		
	Stencil Duplica- tor	50 W	1	0.2		
Principal's house	Light	60 W	1	1		
	Light	18 W	2	on		
Teacher's quarters	Light	36 W	1	on		

<sup>a</sup>Key: on: permanently on if electricity available, nc: not connected.<sup>b</sup>Illuminance was measured on one of the darkest (min) and one of the most brightly lit (max) student desks; instrument: Lutron lux meter, LX-101<sup>c</sup>Maximum power rating.

Table 5.5: Appliance list survey - Malhaha Primary School

Room	Appliance	Power	Qty.	Hours per day <sup>a</sup>	Illuminance (lux) <sup>b</sup>	
					Min	Max
R 1	Light	18 W	2	on	200	500
R 2	Light	18 W	2	on	120	240
R 3	Light	18 W	2	on	90	190
R 4	Light	18 W	1	on	120	120
R 5	Light	18 W	1	on	80	200
Outside	Light	18 W	2	on		
Admin	Light	36 W	1	on		
	Light	18 W	1	on		
	PC	200 W	3	0.5		

<sup>a</sup>Key: on: permanently on if electricity available, nc: not connected.

<sup>b</sup>Illuminance was measured on one of the darkest (min) and one of the most brightly lit (max) student desks.

well advised to replace the present generator with a smaller single phase unit.

In various interviews, teachers as well as students suggested that the classrooms are generally too dark on overcast or rainy days and, with the notable exception of the traditional thatched classrooms, too hot for effective school work. All classrooms are outfitted with (partly dysfunctional) fluorescent lamps, which, however are reported to be partly insufficient for writing and reading. Thus, either additional lights need to be installed or passive lighting improved. Illuminance measurements were taken in many classrooms and are included in Tables 5.4 and 5.5. The measurements were taken on a sunny morning, around 9:00. The minimum and maximum values refer to illuminances of one of the darkest and one of the most brightly lit student's desks in a classroom. For reference, recommended light levels for general office areas are at least  $350\text{lux}$  (Turner 2001).

A good design for functional classrooms might be one that is based on the traditional bure for an optimum indoors climate, but also offers large windows and additional means of passive lighting for maximum independence of electricity for this purpose.

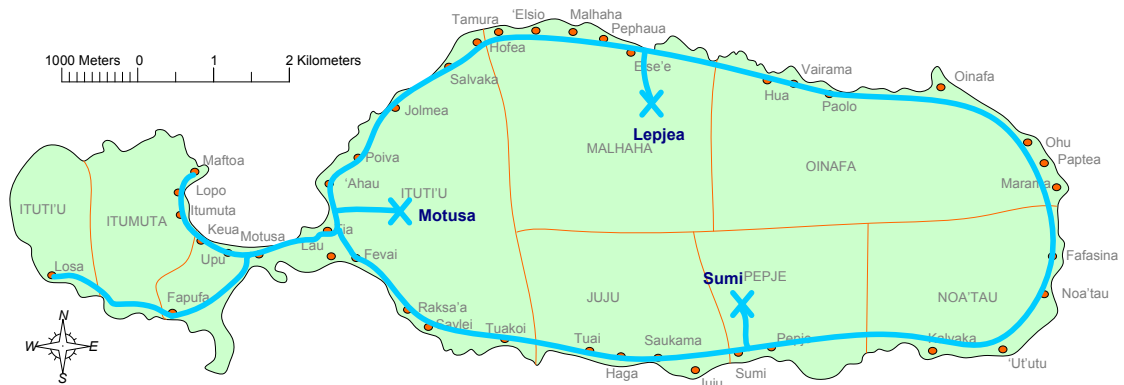

Figure 5.26: Locations of deep wells on Rotuma. The water distribution network is shown in bright blue.

### 5.3.2 Rotuma Water Supply

Due to the importance of fresh water to Rotuma, the water supply system merits detailed attention. Rotuma has no fresh water sources or streams. There are some small fresh water springs, but most are located below the high tide line around the perimeter of the island. All households are connected to a pumped water supply which is maintained by the Fiji Water Supply Unit. There are three deep wells in the interior of the island which tap into a groundwater lens under the island. The borehole locations are shown in Figure 5.26. The wells are between 53 and 72 meters deep. Characteristics for each well are given in Table 5.6.

Both, the Lepjea and Motusa wells were operating nominally during the field survey. However the Sumi pump had no generator. According to Dawe (2001) the Sumi well is prone to salination because the well is located relatively close to the sea. The Sumi well is not normally used for production but maintained for standby use.

#### Water Consumption and Leakage

When the pumped water system was first installed in 1977, Rotuma had a 24hrs tap water supply. However, increasing consumption induced the Water Supply Unit to constrain water supply hours. At the time of the survey, water was usually available from roughly five to nine o'clock in the mornings and from four to five o'clock in the afternoons. Well production and water consumption records are held by the water supply unit but no useful longer term records were retrievable at the time of the survey<sup>3</sup>. It seems most likely that the increase in water consumption is largely due to increasing leakage. In 2001, SOPAC estimated

<sup>3</sup>A worker at the Fiji Water Supply Unit explained that records are often deliberately lost in order to hide occasional inconsistencies

Table 5.6: Characteristics of wells on Rotuma

	Lepjea	Motusa	Sumi
Elevation ( $\pm 2\text{m}$ ) <sup>a</sup>	35m	54m	62m
Borehole depth (mbgl)	53m	63m	72m
Static water level (swl)	34m	54m	61m
Max. recomm. pumping Rate	240l/min	240l/min	120l/min
Actual pumping rates	190l/min	190l/min	90l/min
Water tank capacity	180m <sup>3b</sup>	180m <sup>3</sup>	180m <sup>3</sup>
Well status (June 2006)	Production	Production	Standby <sup>c</sup>
Diesel Generator	Perkins CM50330	Perkins P30i	Perkins P30i
Generator Rating	27kVA	27kVA	30kVA
Pump	Grundfos		

The data was provided by the Water Supply Unit's test records. Tests were conducted by the the Mineral Resources Department in February and March 2003.

<sup>a</sup>Elevations were estimated by (Simpson 1978).

<sup>b</sup>A new 250m<sup>3</sup> tank is being built at Lepjea to replace the current tank.

<sup>c</sup>The pump was defect during the field survey.

the leakage in Rotuma's water distribution system alone to be more than 30%. However, it appears that the major leakages occur on the end user side. Many household piping installations, toilet flushing units, and taps have leaks. Some households leave their taps on most all of the time in order to refill rain water collection tanks as soon as the water comes on. This is particularly common if the guttering on the respective houses has broken down and rain water could no longer be collected<sup>4</sup>. The water supply unit charges households for water use on the basis of individual water meters but fees collection is not enforced. Short term water consumption records for the entire island were obtained from the Water Supply office on Rotuma. The records date from October 2004 though January 2005. These data are useful for understanding how much water is consumed and for estimating how much water might be lost through leaks. The data set included all 468 water meters that were currently connected on the island. A histogram of individual (households and others) water consumption is shown in Figure 5.27. The chart shows daily water consumption bins over equally sized fractions of the metered consumer entities. Notably, 60% of the total water consumption can be attributed to 20% of consuming entities. No businesses, schools, or households on Rotuma were found to have unusually high water requirements. It appears reasonable to assume that high consumption values are due to leaks. For a crude estimate of household water leaks, it is assumed that the median water consumption of the recorded data equals the theoretical mean water consumption if no leaks were present. Water losses would thus be 60% of the supply. However, this is a conservative estimate, because it was observed that virtually all households have at least some minor leaks. Additionally to the consumer level water leaks, there are leaks in the water distribution system. Water production numbers for the same period are listed in Table 5.7. Comparing the total production of 33,730m<sup>3</sup> to the total consumption of 25683m<sup>3</sup> suggests distribution losses of 24%. Combining both losses results in total water losses of at least 69%. For comparison, a typical value of total water leakage in a well maintained system in a developed country would be around 5%.

### Water Production Efficiency

All three wells have their individual electricity supplies to power electric pumps. Electricity is supplied by Diesel generators. The Diesel generators are oversized and operate below their recommended minimum load. Resulting Diesel consumption is more than double of what it normally would be.

All wells on Rotuma use submersible pumps of the type Grundfos SP 14A-18 fitted with submersible MS-4000 electric motors. The nominal flow rate is 14m<sup>3</sup>/h.

---

<sup>4</sup>This is to be seen in the context that spare parts for plumbing items including all guttering supplies are not available on Rotuma, but would have to be especially ordered from Fiji.



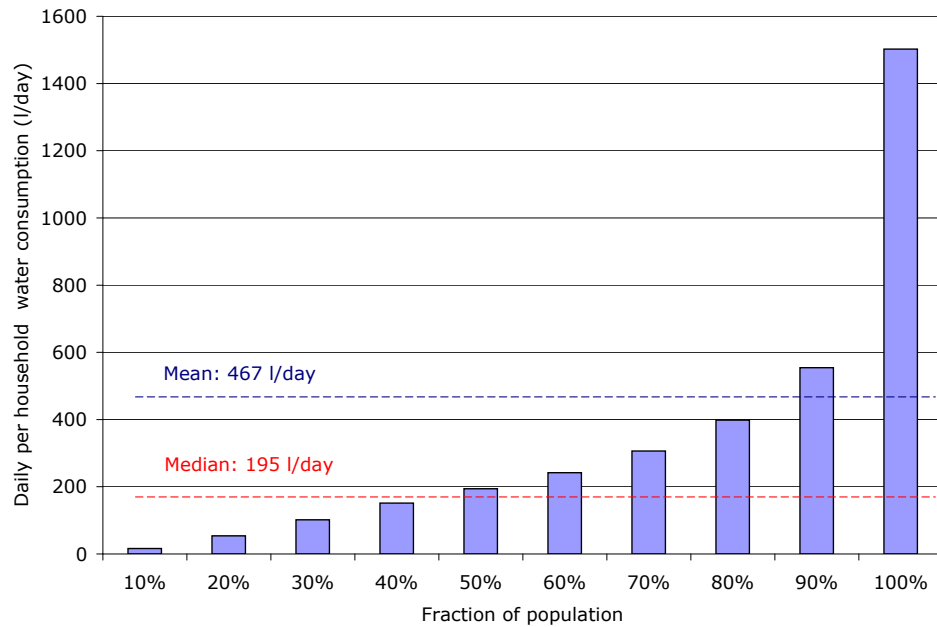

Figure 5.27: Distribution of water consumption over equally-spaced fractions of population.

Table 5.7: Pumped Water Production Statistics

	Lepjea	Motusa	Sumi
Oct. 2004	2480m <sup>3</sup>	3770m <sup>3</sup>	2360m <sup>3</sup>
Nov. 2004	Breakdown <sup>a</sup>	5650m <sup>3</sup>	Breakdown <sup>b</sup>
Dec. 2004	Breakdown	6360m <sup>3</sup>	Breakdown
Jan. 2005	6540m <sup>3</sup>	6570m <sup>3</sup>	Breakdown

The data is taken from the Water Supply Unit's pump logbooks.

<sup>a</sup>The generator coils burned out, parts were sent to Suva for repair.

<sup>b</sup>The fuel pump failed and was sent to Suva for repair. A replacement fuel pump arrived on Rotuma nine months later.

The following is an attempt to quantify inefficiencies in the current pumped water supply system. Electric power requirements are calculated for each well and Diesel consumption is calculated for both, the actual systems and for hypothetical systems that would be sized appropriately.

The electric energy  $P_{el}$  required for the pump is calculated:

$$P_{el} = \frac{H_g \cdot Q_n \cdot \rho_{H_2O}}{367 \cdot \eta_{pump} \cdot \eta_{motor}} \quad (\text{Grundfos 2006}), \quad (5.1)$$

where  $H_g$  is the gross head,  $Q_n$  the nominal flow rate and  $\eta_{pump}$  and  $\eta_{motor}$  the efficiencies of pump and pump motor. The gross head is the sum of static head  $H_s$ , friction head  $H_f$ , and additional lift from pump site to the reservoir. Efficiencies for pump and pump motor at the respective operating points are specified in (Grundfos 2006). Appropriate generator capacities, at the lack of power factor control, are given by dividing the electric power  $P_{el}$  by the power factor of the motor at the respective operating points. Diesel fuel consumption  $F$  is calculated as

$$F = \frac{P_{el}}{\eta_{gen} \cdot LHV_{diesel} \cdot \rho_{diesel}} \quad (5.2)$$

$LHV_{diesel}$  and  $\rho_{diesel}$  refer to the lower heating value and density of diesel fuel. The generator efficiency at the respective operating points are determined by a generic fuel efficiency curve, typical for the types of generators used<sup>5</sup>. Results for the calculations above are shown in Table 5.8. Thus, if the generators would be replaced by appropriate models and leaks fixed, the diesel fuel consumption could be cut to roughly 1/6 of current consumption.

The author visited the headquarters of the Water Supply Unit in Fiji in order to follow up on the inefficiencies. When asked about the grossly oversized diesel generators, one of the water supply engineers explained that generators are often chosen according to what a particular supplier currently stocks, rather than required size. The leakage problem was reported to have evolved as follows: since there is no professional plumber on Rotuma, the Water Supply Unit was officially liable for fixing reported household leaks. However, it appears that the Water Supply Unit in Rotuma under its previous management has seldom followed up on the repair requests. Additionally, the head of the Rural Water Supply department explained that he had to sack the previous head of Rotuma's water supply division because of inconsistencies connected to diesel fuel supplies. As can be seen, a range of issues needs to be addressed in order to bring about effective and lasting improvements in Rotuma's water supply system.

---

<sup>5</sup>Efficiency is expressed as a function of the instantaneous capacity factor.

Table 5.8: Water Pumps Characteristics

	Lepjea	Motusa	Sumi
Gross head $H_g$	41m	59m	67m
Nominal flow rate $Q_n$	12m <sup>3</sup> /h	12m <sup>3</sup> /h	6m <sup>3</sup> /h
El. power req. $P_{el}$	2.79kW	4.02kW	2.63kW
Ideal generator size <sup>a</sup>	4.90kVA	5.58kVA	4.62kVA
Capacity factor (optimal)	0.67	0.85	0.67
Capacity factor (real)	0.12	0.14	0.11
Diesel consumption (optimal)	1.01l/h	1.36l/h	0.96l/h
Diesel consumption (is)	2.58l/h	2.92l/h	2.68l/h

The data is based on calculations...

<sup>a</sup>This is the generator size that is required if no power factor compensation is built-in to the system. Power factor values are taken from the Grundfos pump motor specifications (Grundfos 2006).



(a) The pump house.



(b) Water supply reservoir. The tank holds 180m<sup>3</sup>.

Figure 5.28: Lepjea pumping station - one of the three deep wells on Rotuma.



Figure 5.29: Hospital on Rotuma.

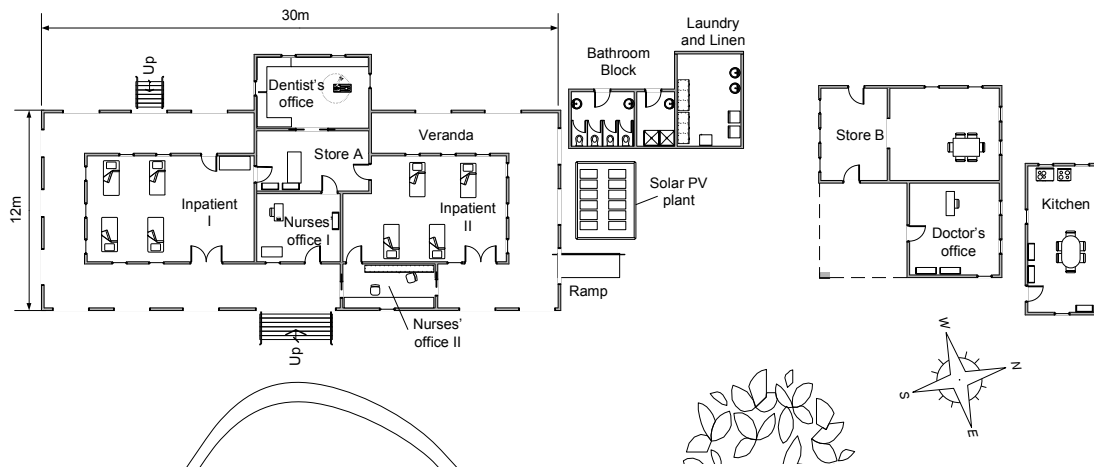

Figure 5.30: Hospital on Rotuma.

### 5.3.3 Hospital

The Rotuma rural hospital is administered and funded by the Fiji government. Treatment at a government hospital is free of charge in Fiji. Rotuma's hospital offers approximately eight beds for stationary patients. An average occupancy appears to be about three patients. Head of the hospital is Dr. Susana Pene. Other staff include a further doctor, and several nurses. Two to three nurses are on duty during daytime, and one at night. The hospital also features a separate area for dental treatments.

Electricity is supplied to the hospital by the government operated generator at the Ahau Government Station. Additional electricity for after hours<sup>6</sup> is provided by a solar PV power station. The solar system components are listed in table 5.9. The solar plant has a theoretical annual average output of approximately 3.99kWh/day, or 2.79kWh/day if panel to batteries system efficiencies are

<sup>6</sup>The government generator operates from 8:00 to 13:00, and from 18:00 to 23:00 every day.

Table 5.9: Solar system at Rotuma hospital.

Component	Model	Ratings	Qty.
Solar PV panels	-	80W	12
Charge controller	Trace C40	40A	1
Batteries	CenturyYuasa <sup>®</sup> , Enersun	700Ah, 6V	4
Sinewave inverter <sup>a</sup>	-	5kW, cont.	1

<sup>a</sup>The inverter was in Fiji for repair at the time of survey

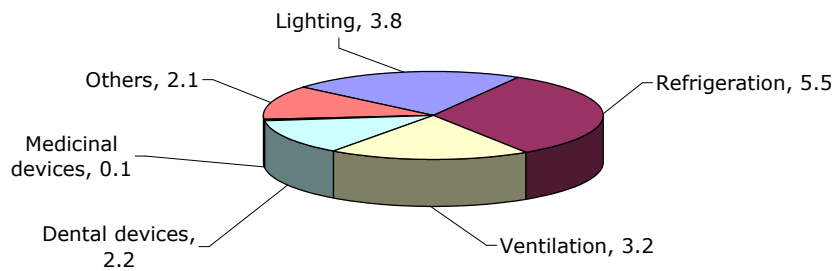

Figure 5.31: Energy use in Rotuma hospital. All values are in kWh per day.

included<sup>7</sup>. The solar system had been donated to Rotuma by a Japanese foreign aid agency. Measurements could not be done because the solar system was shut down during the survey period because of an inverter breakdown.

The hospital also owns two backup generators, which are used in emergencies or if the government generator fails. The Diesel generators are single phase, and portable. One is a Workmate APY50ESID, 5kVA generator by Advanced Power with an energy consumption of 1.5l/hour; the other is a Robin RGD5000 generator at 5kVA. The generators are reported to be used roughly 20 times a year, for about six hours per use.

Appliances employed at the hospital are listed in Table 5.10. A large portion of these appliances find only very occasional use. Most regularly used are lights and ceiling fans. Appliances are broken down to categories and the contribution of each category to the total energy bill is shown in the pie chart in Figure 5.31.

Actual energy bills or energy use records could not be obtained, but a likely loadcurve, based on the appliance data, generator run time and reports by the staff was created and is shown in Figure 5.32.

<sup>7</sup>This estimate is based on modelling the system in Homer, at solar irradiation data presented in section 6.3

Table 5.10: Appliances at the Rotuma Rural Hospital

Room	Description	Qty.	Power	Hours <sup>a</sup>
Inpatient I	Fluorescent light	2	36W	6
	Ceiling fan	2	120W	3
	Suction machine	1	250W	0
Nurse II	Fluorescent light	1	36W	6
	Autoclave	1	1,500W	-
Inpatient II	Fluorescent light	2	36W	6
	Fluorescent light (rechargeable)	2	18W	4.5
	Ceiling fan	2	120W	3
	Sysmex <sup>®</sup> blood analyser	1	230W	0
	Roche <sup>®</sup> reflectance photometer	1	45W	0
	Ratek <sup>®</sup> blood tube roller	1	5W	0
	X-ray viewing light	1	150W	0
	Nebulizer	2	100W	0.5
Store A	Dr. Lee <sup>®</sup> , ECG-120B el. cardiograph	1	21W	0
	Fluorescent light	3	36W	6
	F&P <sup>®</sup> , Kelvinator C270 refrigerator	1	190W	6
Nurse I	Kettle	1	2,000W	0.3
	Fluorescent lights	2	36W	6
	Table fan	1	40W	6
Veranda	Fluorescent lights	3	18W	6
	X-ray machine	1	200W	0
Dentist	Fluorescent light	1	36W	6
	Dentist chair	1	950W	0.1
	Handyclave, LS-1 sterilizer	1	1,000W	2
	Dentsply, Cavitron SPS scaler	1	95W	0.5
	Hilux <sup>®</sup> curing light	1	100W	0.1
	SDI <sup>®</sup> amalgameter	1	60W	0.5
	Meladist <sup>®</sup> 65 distiller	1	800W	0
Laundry	Simpson <sup>®</sup> , Esprit 750, washer	1	150W	2.2
Doctor	Fluorescent light	1	36W	7
	Ceiling fan	1	110W	7
	Computer	1	110W	5
	Refrigerator (small)	1	120W	6
	Ricoh <sup>®</sup> fax	1	600W	0
Store B	Fluorescent lights	2	36W	7
	Ceiling fan	1	110W	7
	Clothes iron	1	600W	1
Kitchen	Fluorescent light	1	36W	4
	F&P <sup>®</sup> , Frigidaire freezer	1	280W	8
	Refrigerator (combo)	1	200W	7
	Phillips <sup>®</sup> blender	1	400W	0.1

<sup>a</sup>Per day. If device is not used regularly, hours are given as 0.

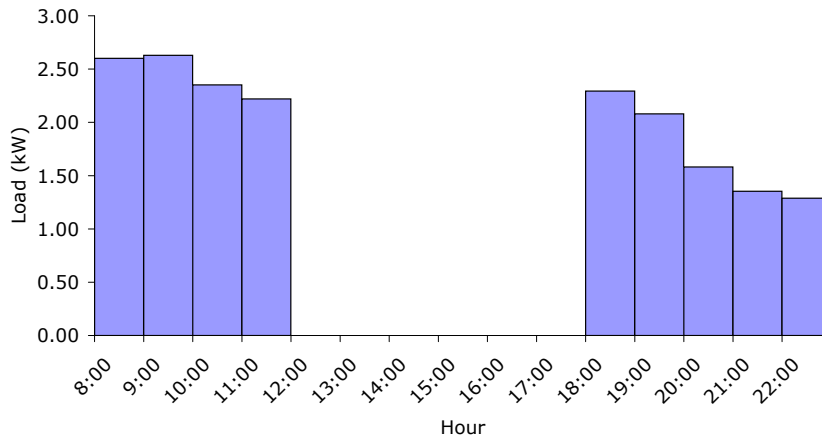

Figure 5.32: Energy use in Rotuma hospital. All values are in kWh per day.

### 5.3.4 Additional Surveys

A large number of additional surveys have been carried out on Rotuma at various businesses, institutions, and households. Reporting all of them here would go beyond the scope of this document. Instead, these surveys are included in the appended CD. Surveys on the CD include:

#### *Domestic*

---

Private household at Malhaha (includes a partly dysfunctional PV installation)  
 Private household in Oinafa (includes a dysfunctional PV and wind power installation)

Private household in Oinafa (includes a highly successful small PV installation)

#### *Governmental*

---

Government Station

Fiji Telecom (features the largest solar PV installation on Rotuma, status is partly dysfunctional)

Public Works Department

Rotuma Airport (includes a solar PV installation)

#### *Businesses*

---

Mamfiri Oils

Nigel's retail outlet in Lopta (includes a solar PV installation)

Sisters Enterprises, Oinafa

Malhaha Bakery (wood fired ovens)

Juju Bakery (diesel/electric ovens, out of service)

## 5.4 Energy Flows

To summarize this chapter and in order to place electricity use in the context of other energy uses, an energy flow chart was created which includes all of the

significant energy uses that could be identified. Also included are energy uses for transport to and from the island by boat and airplanes. Sources for the underlying data include various fuel import and redistribution records (kindly provided by Sisters Enterprises), interviews with the Water Supply Unit and the PWD, and fuel consumption figures provided by Air Fiji and by Western Shipping, the operator of the Cagi Ma Ba supply ship to Rotuma.



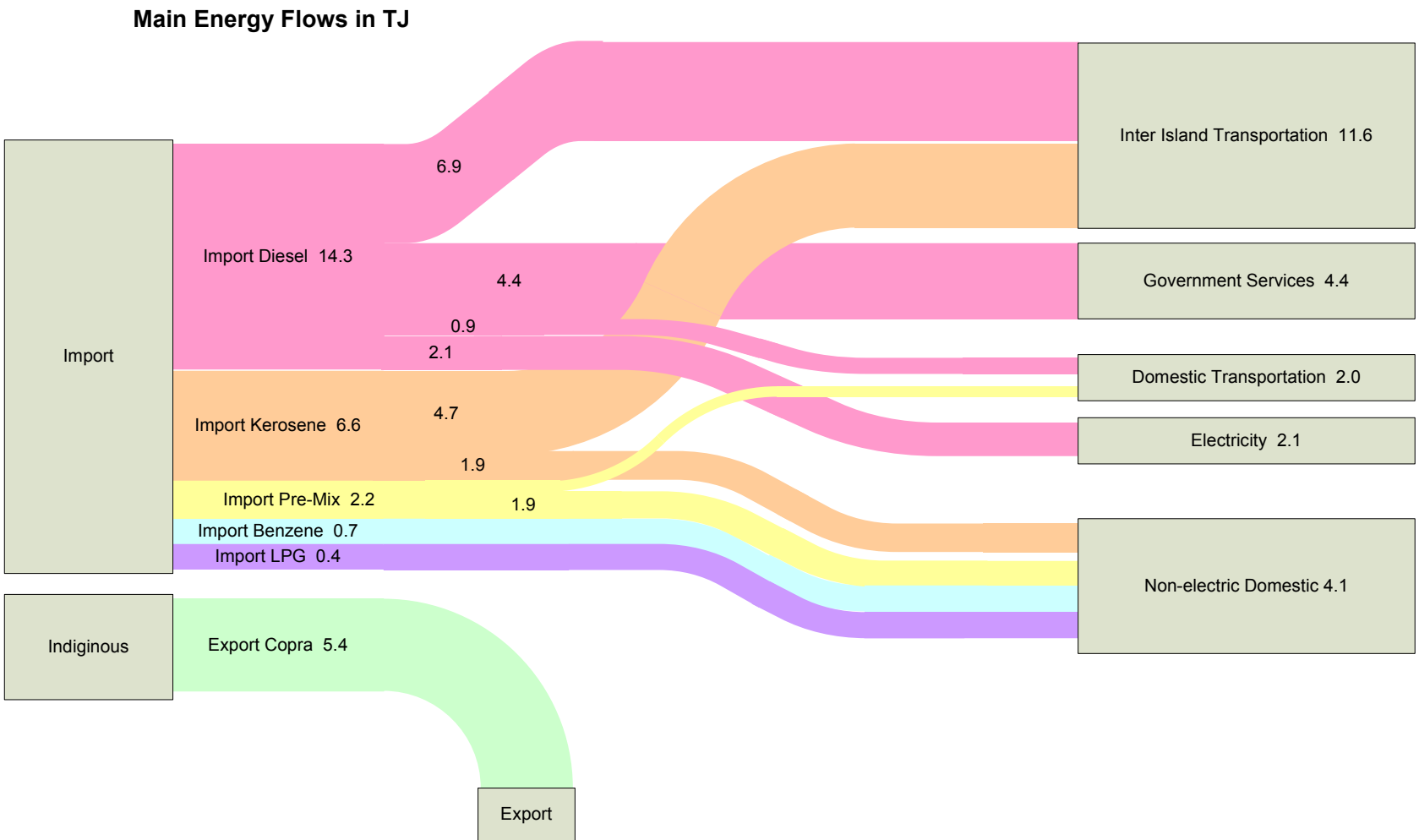

Figure 5.33: Main energy flows on Rotuma in TJ. For comparison, current rates of copra export are added. Copra energy values reflect the energy content of coconut oil that could be produced from the copra.

## Chapter 6

# Rotuma Energy Resources

Energy resources indigenous to the island are limited. There are no known fossil fuel deposits, such as coal, oil, or natural gas. Hydro electric power is not possible due to the lack of fresh water bodies. There is a variety of potential renewable energy resources, the most promising appeared to be coconut oil, solar energy, and wind power. Interviews with elders on Rotuma suggested that coconut oil has been traditionally used as a fuel for lamps and reef fishing torches. Coconut palms are well established on the island, and copra has been the main export from Rotuma since its inception in the early 20th century. Modelling and observations confirmed that mean wind speeds in the general area had been systematically underestimated, however, extended calm periods entail large electricity storage requirements. The sun is a reliable source of energy on Rotuma, but the high moisture content in this tropical climate limits its exploitation to technologies that do not require direct irradiation. Those three energy resources have been analyzed and are the subject of this chapter. Other sources of renewable energies have been discounted for electricity generation, because they lack significant advantages over one of the resources above (other biomass resources such as wood), or there are no commercial technologies to harness the energy (e.g. farmed algae, wave power, tidal power).

### 6.1 Copra Resources

Coconut oil has an important traditional standing on Rotuma, and the coconut palm being one of the most versatile plants on the island. The cross section of a coconut is shown in Figure 6.1. The husk on the outside is extremely fibrous and, among others, has been traditionally used for making (Isapeti Inia, personal communication), as well as wicks for lanterns (Samo Fangerea, personal communication). Coconut shells make durable storage containers. The immature coconut flesh is consumed as a snack at all stages of maturation, and coconut milk is considered an energy drink. Fermented coconut flesh and coconut cream

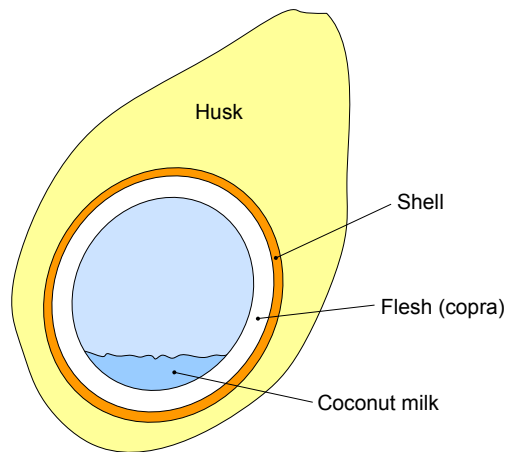

Figure 6.1: Section through a coconut.

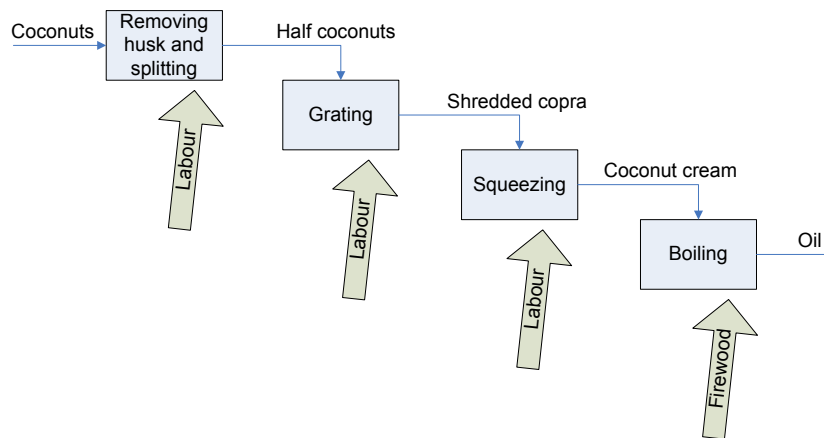

Figure 6.2: Traditional coconut oil processing chain, as practiced on Rotuma.

(the juice extracted from squeezing the grated coconut flesh) are important ingredients in traditional Rotuman cooking. Coconut oil is extracted from coconut cream by boiling off the water, and used for cooking and or for cosmetic purposes. Coconut leaves are used for weaving baskets and occasionally for thatching houses.

### 6.1.1 Avenues of Coconut Oil Production

Coconut oil has been traditionally produced on Rotuma in small quantities. The traditional processing chain from coconut to oil is shown in Figure 6.2. The coconut is freed of its husk, split in half, and grated on a special coconut grater. The grated flesh is then squeezed through a cloth. The result is relatively dry press cake and coconut cream. The cream can be used for cooking, or further processed to oil. This is done by boiling the cream until all the water is evaporated

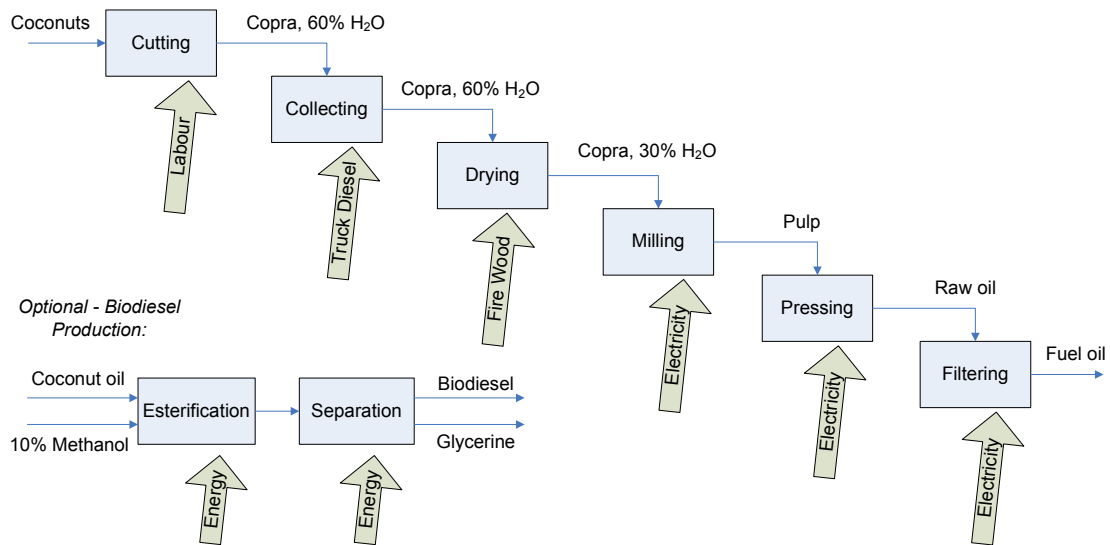

Figure 6.3: Commercial coconut oil production processing chain.

and only oil remains. This method is time consuming but suitable for household scale production, for usually less than a liter at a time. The processing chain of coconut oil for commercial production is shown in Figure 6.3. While this is done in some cases, it is unpractical to deliver whole coconuts to the pressing facilities because these take up immense volumes. Instead, the copra is generally cut out of the nuts on the plantations and transported to local storage and drying facilities. Copra is dried from 60% to a maximum 30% residual moisture before it is stored in bags and periodically delivered to the press. At the plant, copra may be dried further as required, and is then crushed and pressed under high pressure. The coconut presscake or pomace can be used for animal feed. The coconut oil is filtered and further residual water is removed.

The resulting coconut oil can be used in modified diesel engines, pure or in blends with diesel of different concentrations. Mainly depending on the injection technology, not all diesel engines will work with pure coconut oil.

It is also possible to process coconut oil into biodiesel, however, this requires a 10% feedstock of methanol, a very toxic alcohol. Ethanol cannot be used in conjunction with coconut oil. The esterification process yields biodiesel and glycerin. While the use of biodiesel in engines is less problematic than pure oil, the production of biodiesel is not considered a realistic option for Rotuma. This is due to the requirement of large quantities of imported methanol as well as the level of technology involved.

## 6.1.2 Coconut Resource

The coconut resource potential on Rotuma has been described in the Burgeap (2006) report. According to a recent report for the Coconut Industry Develop-

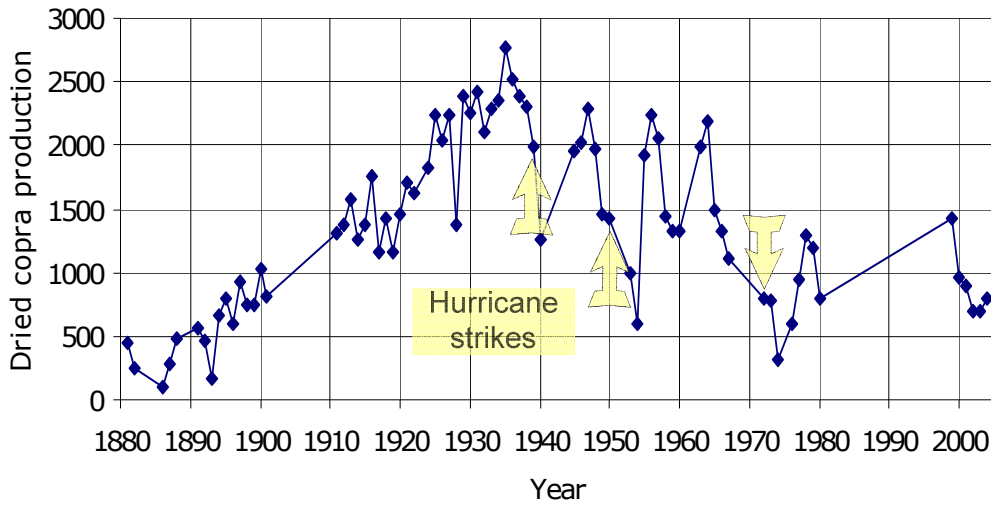

Figure 6.4: Annual copra production on Rotuma in tons per year. Sources: (Rensel 1993) and (BURGEAP 2006).

ment Authority (CIDA 2004), 59% or 2615ha of the Rotuma's total land area of 4400ha was under coconut. All coconut trees are reported to be of productive age. Most present trees were planted in 1970, with the majority of trees of the Rotuma Tall variety. According to (BURGEAP 2006), sources on Rotuma suggest a maximum annual production of between 4.4 to 4.8 tons of dried copra (10% moisture content) per ha. Current production averages 0.3 tons of copra per ha, i.e. 7% of the theoretical maximum. This low value has several reasons. Only part of the coconut resource is actually collected and processed, while a large portion remains under the trees to rot. The development of copra production over the last century is shown in Figure 6.4. The most recent decline in production is largely attributed to the collapse of the Rotuma cooperative system in 1993/94 (BURGEAP 2006). According to Rensel (1993), previous fluctuations have a variety of explanations: The production increase in the 1940's is attributed to the introduction of motorized vehicles, but was finally limited by the lack of drying and storage facilities. Copra price declines tended to cause production declines. In particular, the 1939, 1948, and 1972 hurricanes incurred sharp drops in production for the following one or two years, respectively.

CIDA (2004) estimates that the total copra production on Rotuma can be raised to 1500t/a with the existing trees only, and to roughly 12,000t/a after extensive new planting. All estimates assume that the current portion of land under coconut is the maximum land area available for planting, other areas being either inaccessible, unsuitable, or used for other purposes.



(a) Freshly cut copra on the side of the road waiting for pickup by the daily collection truck.



(b) Well maintained copra plantation in the interior of Rotuma.

Figure 6.5: Copra production on Rotuma in 2006.

## 6.2 Wind Resources

### 6.2.1 Global wind patterns and wind data

As an idealized model, the earth can be imagined as being encircled by six broad wind belts, which are separated by narrow belts, so called zones of subsidence or ascent (Fig. 6.6(a) and 6.6(b)). Wind direction and position of the belts is largely determined by the earth's rotation (East-West flow) and solar radiation (North-South flow). The resulting three global circulation patterns are the Hadley Cell, Ferrel Cell, and Polar Cell. This model is the basis of understanding global wind patterns and a starting point for understanding local wind patterns on Rotuma.

#### Hadley Cell

The high average solar radiation in the vicinity of the equator causes air to heat up at the surface and rise. The result is the Intertropical convergence zone (ITCZ), a band of low air pressure centered on the equator. The ITCZ reaches from about 5 degrees N through 5 degrees S, within which winds are light and capricious in direction. Surface air from the subtropics is drawn into the ITCZ. Northern and Southern winds converge and the famous equatorial thunderstorms cause convection of the heated air into the upper troposphere (12 to 15km). There it can't rise any further and is forced to begin flowing horizontally due North and South in order to drop down again at around 30 degrees North and South. Surface winds generated by the Hadley cell are known as the Northeast and South-East Trade winds, respectively. The East/West deflection of the winds is caused by the Coriolis force from the earth's rotation.

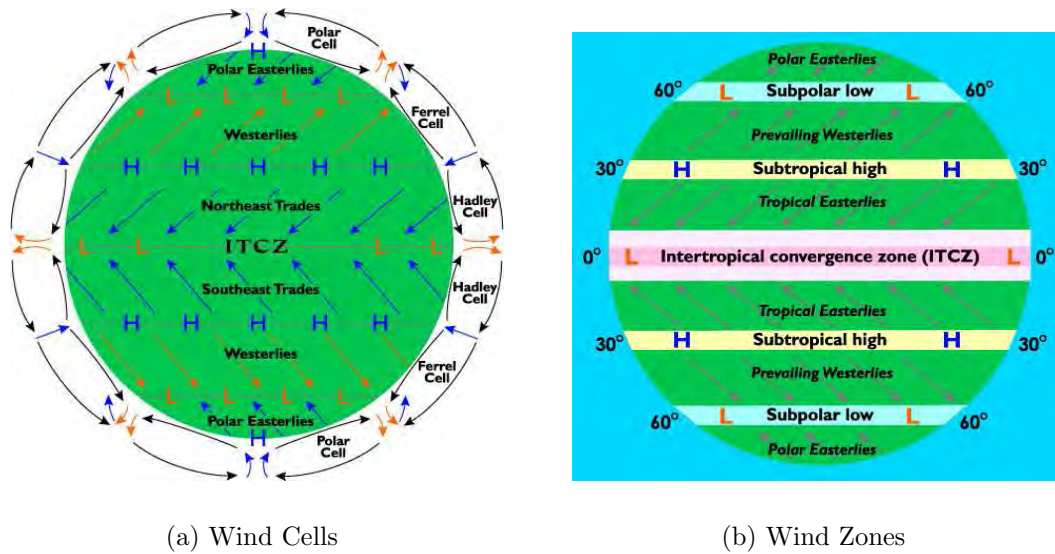

Figure 6.6: The Global Wind Systems (From <http://www.newmediastudio.org>)

At its  $12^{\circ}\text{S}$  latitude location, Rotuma is located within the Hadley cell area, and well clear of the ITCZ. Therefore, we expect Rotuma to be exposed to prevailing South East Trades.

### Ferrel and Polar Cells

The descending air of the Northern and Southern branch of the Hadley cell causes a narrow band of high air pressure, the subtropical high. In the subtropical high zone, the air flow splits up again and travels towards equator and poles. The pole-ward boundaries of the Ferrel cells are the equatorial bands of low pressure. The Westerly spin of the air is, once again, due to the Coriolis force from the earth's rotation. The same phenomena are responsible for the Polar cells, where air rises in the equatorial bands of low pressure and descends in the Polar Highs.

## 6.2.2 Global Wind Maps

Global wind maps were used as a starting point for wind prospecting on Rotuma. Detailed wind maps are available for some regions in the world but not for South Pacific Islands. Fig. 6.7 shows a wind map of the entire globe. Numbers on the map refer to the mean wind speed in  $m/s$  at  $10\text{m a.g.l.}$ <sup>1</sup> for the period 1976-95, according to the NCEP/NCAR reanalysis data set. The approximate position of Rotuma is highlighted on the map, suggesting that it lies in a  $6m/s$  average wind zone (Class 4).

<sup>1</sup>a.g.l. stands for above ground level.



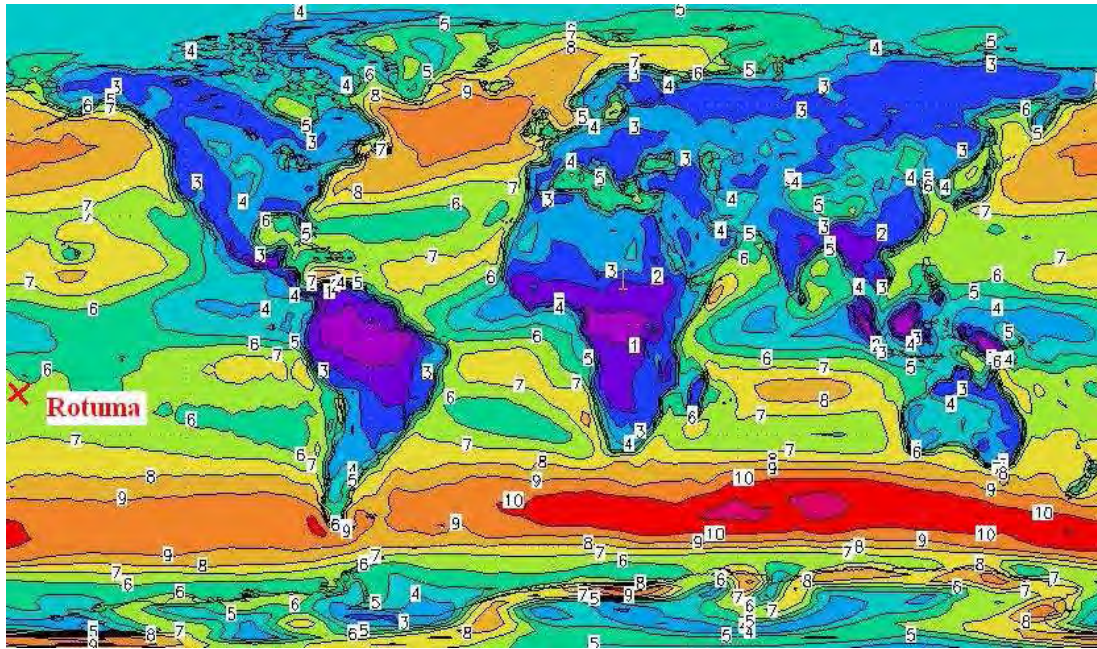

Figure 6.7: Global Wind Map (<http://www.windatlas.dk/World/Index.htm>)

A recent global wind map produced by Stanford University delivers contradictory results: The Stanford Wind mapping Program's map (Fig. 6.8 suggests class one wind resources for the Rotuma area. However, Stanford's wind map appears to be built upon questionable data. Archer's remark (2005): "Even though data were available from 490 soundings and 8071 surface locations, only stations with at least 20 valid readings in a year were utilized in this study" suggests that her station selection standards were low. It is likely that Stanford's wind map systematically underestimates average winds in the Pacific, because weather stations in the region are generally inadequately exposed. The US wind report reads:

Wind data from the Pacific Islands are sparse. Approximately half of the documented stations have questionable anemometer heights and exposures as a result of inadequate documentation. Wind power densities were available for some of the islands. Except for some of the small atolls, open-ocean wind power considerably exceeds island values. Apparently, well-exposed sites are rare in the Pacific Islands. Available site descriptions consistently mention adjacent stands of coconut palms. (Elliott et al. 1986)

The Stanford Wind mapping data is thus ignored for this study.

### 6.2.3 Rotuma Weather Station Data

There is one weather station on Rotuma, located within the Ahau Government Station. For this study, wind data was available for the years 1999 through



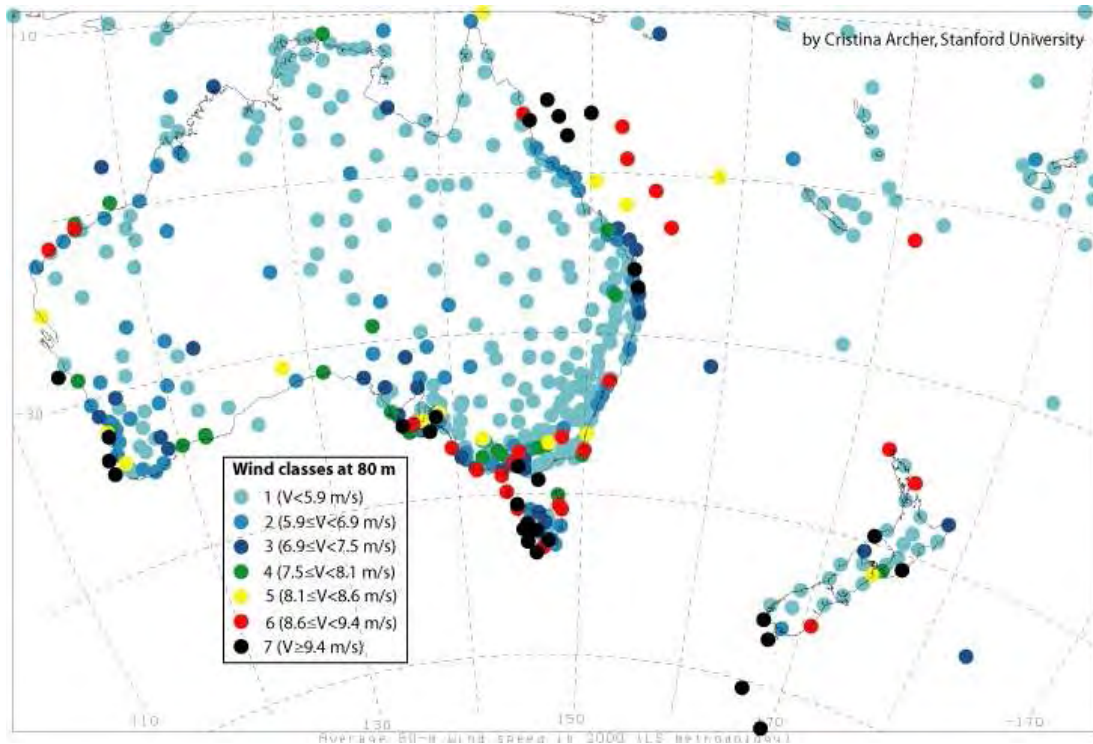

Figure 6.8: Stanford University Global Wind Map (Archer and Jacobson 2005)

Table 6.1: Classes of Wind Power Density at 10m and 50m (Vertical Extrapolation based on 1/7 power law)

Class	10m		50m	
	Density [ $W/m^2$ ]	Speed <sup>a</sup> [ $m/s$ ]	Density [ $W/m^2$ ]	Speed [ $m/s$ ]
1	to 100	to 4.4	to 200	to 5.6
2	to 150	to 5.1	to 300	to 6.4
3	to 200	to 5.6	to 400	to 7.0
4	to 250	to 6.0	to 500	to 7.5
5	to 300	to 6.4	to 600	to 8.0
6	to 400	to 7.0	to 800	to 8.8
7	to 1000	to 9.4	to 2000	to 11.9

Adapted from: (Elliott et al. 1986)

<sup>a</sup>Mean wind speed is based on Rayleigh speed distribution of equivalent mean wind power density. Wind speed is for standard sea-level conditions. To maintain the same power density, speed increases 3%/1000m elevation.

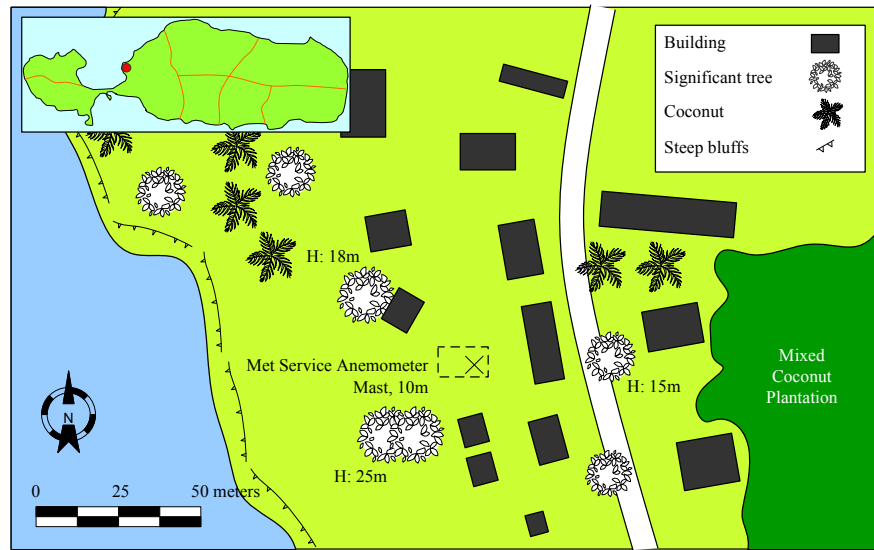

Figure 6.9: Position of Rotuma weather Station,

2005, as well as several months of 2006. However, at an average of 75%, data availability is fairly low. The data collection frequency of three hours is also low. The 10m anemometer mast is located on a flat area raised above the coastline through steep bluffs by about 25m above mean sea level. As illustrated in Figure 6.9 the mast is poorly exposed. Two large 25m mango trees shade the mast from the South-West, a 15 meter tree distorts winds from the East and an 18m tree blocks out the view to the North-West. All buildings in the map are less than 5 meters tall. Apart from poor local exposure, the station is located in a very bad position for capturing the prevailing winds in the area, the South East trades. The station is located in the wind shade of the tallest hills on the island, obstructing the entire sector from roughly East through South-East.

The available wind data from the Rotuma weather station (2000 through 2005) indicates an average wind speed of only 1.98m/s. This is in contrast with what would have been expected given the global wind map in Figure 6.7, which suggested a value closer to 6m/s. However, the sheltered location of Rotuma's weather station may explain the low values obtained. Generally, wind readings from Rotuma can be expected to be inaccurate. The data is manually read out by the weather station operator from a mechanical display. Wind directions have also been recorded, but no wind vane exists. Wind directions are estimated by the operator, and the accuracy of these data is believed to be no better than  $\pm 45^\circ$ . The weather station data are therefore not sufficient for assessing the wind power potential of Rotuma. However, the data are useful as long term observations for analyzing typical weather patterns. The wind rose of sectoral wind frequencies (Figure 6.10) confirms that the South East trades are dominating the local wind patterns. The seasonal wind distribution is shown in Figure 6.11.

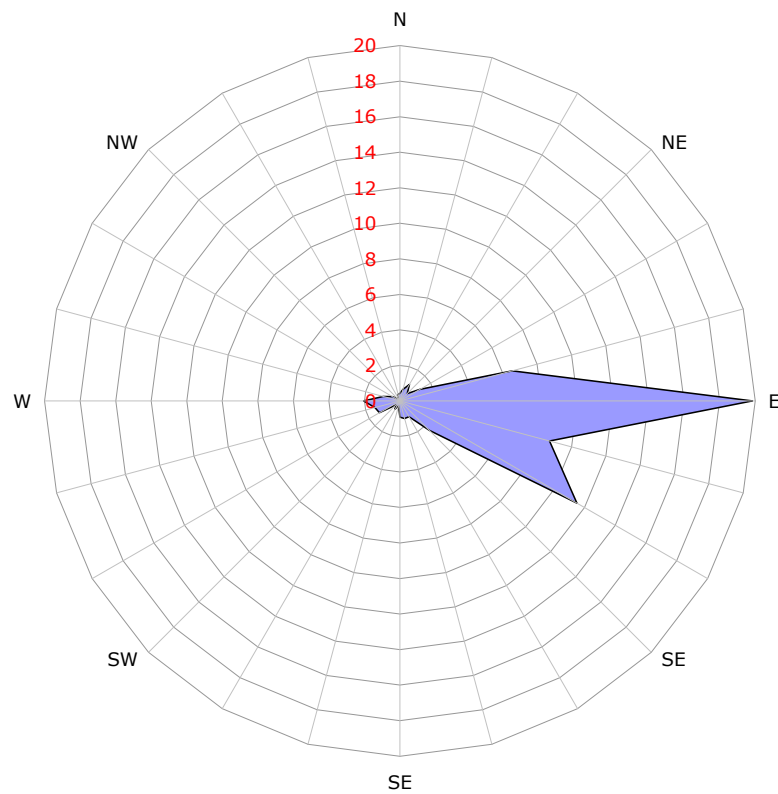

Figure 6.10: Wind frequency rose for Rotuma, based on data from the MetService weather station, 2000 to 2006. The axis shows frequency values in %, with values based on 24 angular sectors.

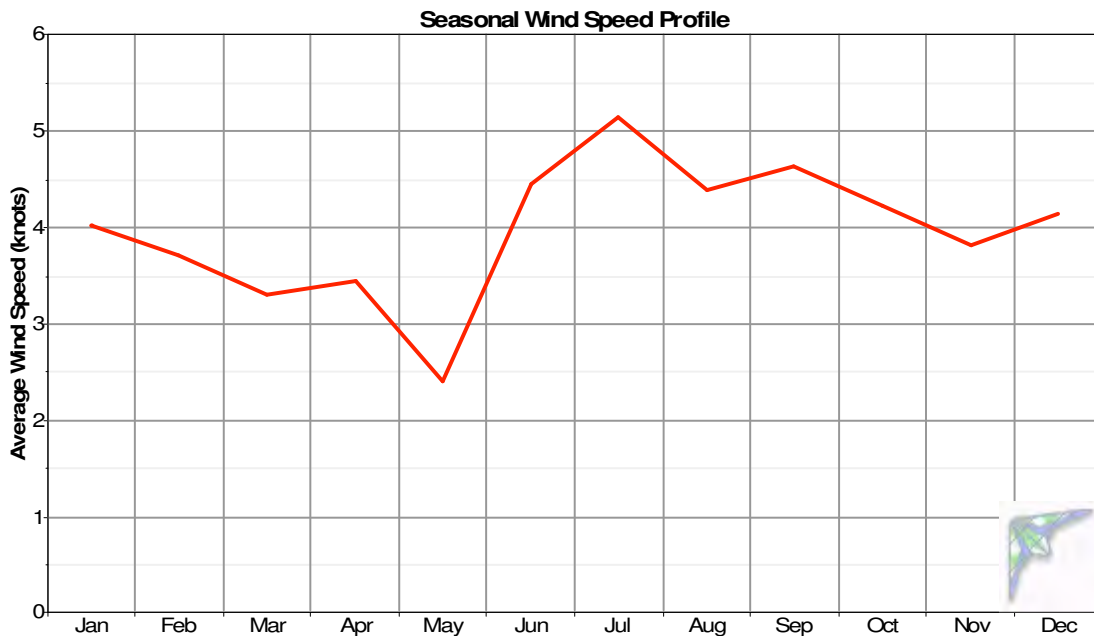

Figure 6.11: Seasonal wind profile on Rotuma, based on data from the MetService weather station, 2000 to 2006.

#### 6.2.4 Wind data Collection on Rotuma

Short term (30 days) of wind data were recorded on Rotuma within the scope of the 2006 field survey. Data were recorded using three ten meter masts in the locations shown in Figure 6.12. Photographs of the masts are shown in Figures 6.13(a) through 6.13(d). All data were recorded in ten minute increments. Hourly data were produced as hourly averages of the ten minute data.

All anemometer were calibrated prior to departure to Rotuma. The accuracy of the data was mainly limited by the positions of the masts. It was more difficult than expected to find suitable locations for the anemometer masts. Due to limits in mast heights, none of the masts was perfectly exposed in all directions.

The mast on Afgaha was installed less than 20 meters West of a cliff with an approximate 10 meter drop. It is possible that local effects influenced the data. The anemometer at Ahau was installed on the existing mast of the weather station (see Figure 6.13(b)). Problems with the poor position of this mast have been discussed in the previous section. The Motusa site was the only site on the island where a mast could be installed at sea level with minimal vegetation in the way. However, there was thick growth of taller coconut palms (roughly 20 meters tall) about 60 meters west of the mast. The mast was completely exposed in all other directions, from roughly WSW through WNW.

The limitations of mast positioning need to be taken in to account when evaluating the data.

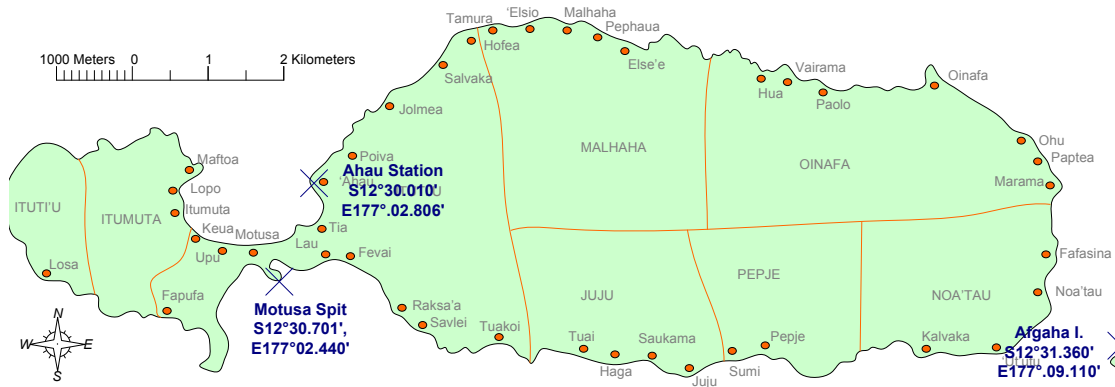

Figure 6.12: Positions of wind masts during field survey on Rotuma.

### 6.2.5 Modelling the Wind Resource

Wind data for modeling purposes were computer generated. The wind resource assessment combined two meteorological models to generate wind maps for Rotuma Island.

The Australian Commonwealth Scientific and Industrial Research Organisation's (CSIRO) TAPM model (The Air Pollution Model), a three-dimensional numerical mesoscale atmospheric model was used to simulate the airflow over Rotuma Island and an area within about 12 km of the island area at a resolution of 800m for 2003. From the six year data of the Rotuma station, 2003 was chosen as a representative year of the longer term wind climatology for this area. The model generated hourly wind data at 1,225 points. At this resolution, the model is able to account for large-scale topographic and surface roughness features, but only provides an overall picture of the wind regime in the region. From the model, hourly wind data was obtained for a virtual mast site at a location about 6 km south of Rotuma Island. This point was chosen to be far enough away from the island due to its effects on the wind regimes but close enough to represent the wind climate for this area.

The hourly wind data derived from it were then used in the high resolution Wind Atlas Analysis and Application Program (WAsP) model to generate detailed wind maps. The WAsP model is able to account for high resolution elevation contour data (for Rotuma given at a 15 m resolution). Surface cover was assumed to be constant throughout the island at a roughness length of 0.4m. Calculations of mean wind speed predictions from the high resolution model were at 50m resolution.

For Rotuma, maps were generated for 10m, 25m, and 50m anemometer heights, respectively. Windmaps are shown in Figures 6.15 through 6.15.

While a full validation of the modeled results was not possible within the scope of this study, mean wind speeds from the map were compared against mean wind speeds of observed data from the three masts in Afgaha, Ahau, and





(a) Ten meter mast on a hill on Afgaha Island.



(b) Ten meter mast at the Ahau government station. The equipment was mounted on top of the existing ten meter mast belonging to the weather station.



(c) Data download at Afgaha. Masts were inspected and data downloaded in two week intervals.



(d) Ten meter mast at the spit South of Motusa.

Figure 6.13: Wind mast installations on Rotuma.

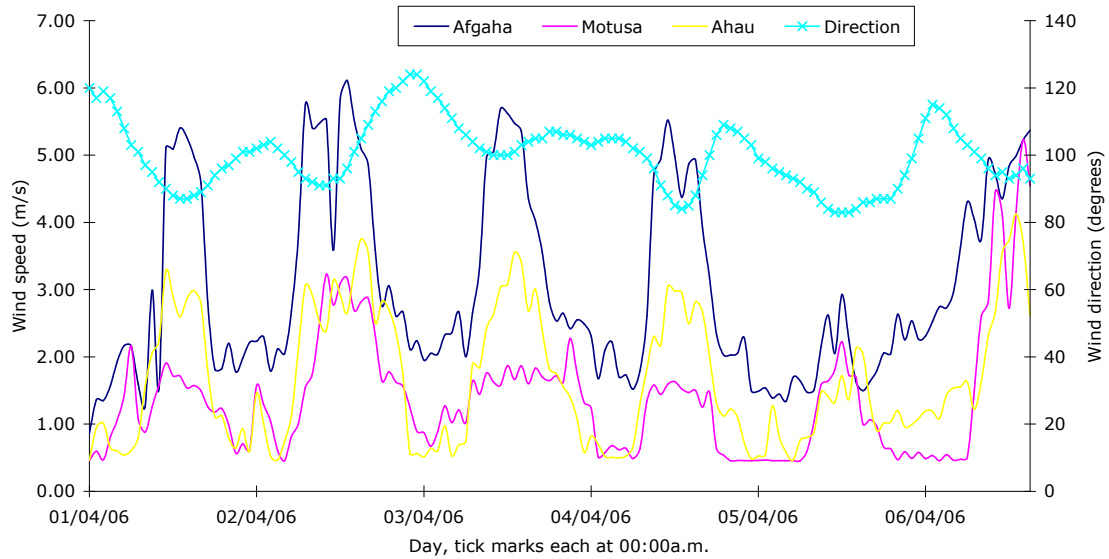

Figure 6.14: Sample of wind data recorded on Rotuma.

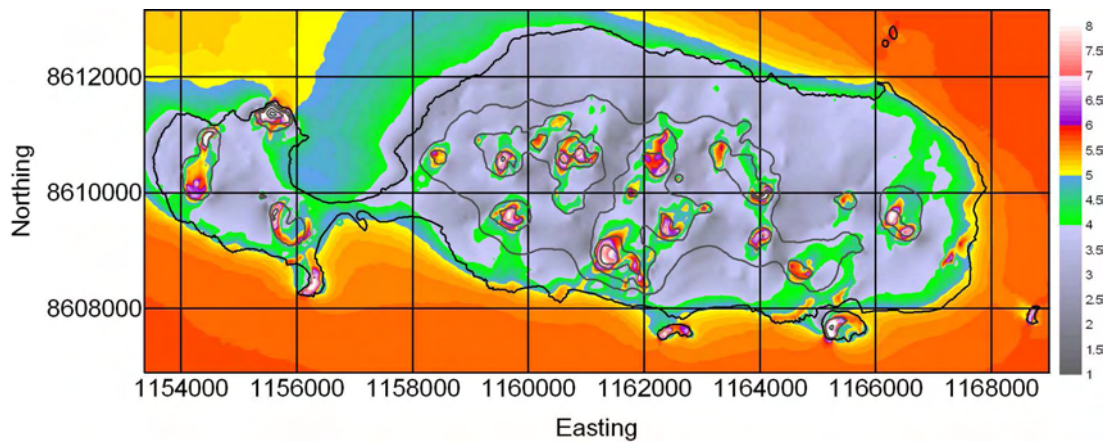

Figure 6.15: Windmap for 10m anemometer height. This wind map is based on data for the period from 19. April through 15. May 2006. This period showed wind values well below annual averages. Contour lines are added for 2 and 3m/s.

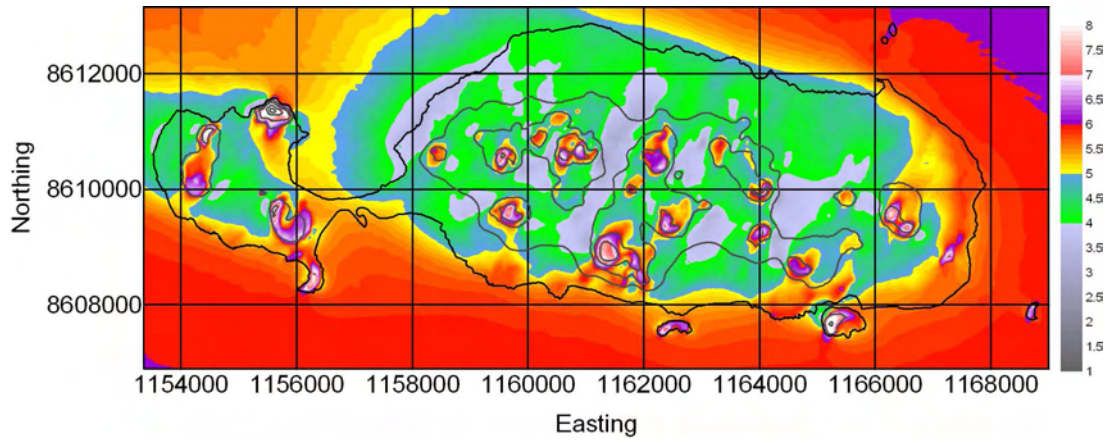

Figure 6.16: Windmap for 25m anemometer height. This wind map is based on data for all of 2003.

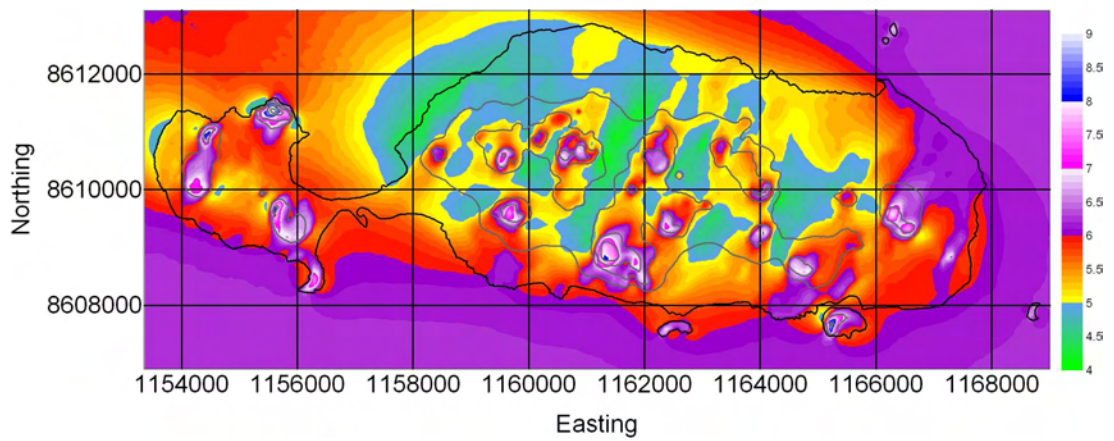

Figure 6.17: Windmap for 50m anemometer height. This wind map is based on data for all of 2003.



Table 6.2: Measured vs. modeled annual mean wind speeds.

	Model	Measured	Difference
Afgaha	3.2m/s	2.5m/s	10%
Motusa	4.2m/s	4.2m/s	7%
Ahau	2.3m/s	2.1m/s	6%

Motusa for an identical period of time. For this purpose, an additional windmap was generated for several weeks in 2006, the period of field wind measurements. Validation results are shown in Table 6.2. The table shows mean wind speeds for the measurement period from 19. April through 15. May 2006. The “model” values were taken from the windmap for this time, the “measured” values are average wind speeds as recorded during the same period. The values are indicative only due to the short data collection period, but increase confidence in the wind mapping results.

### Discussion of Wind Modelling Results

As Table 6.2 shows, the modelled values are in fairly close agreement with the measured wind speeds. While the field data is not sufficient to draw any definitive conclusions about the validity of the model, the model has been tested for various locations in New Zealand leading to very close correlations with long term field data there.

General limitations of the model include the accurate representation of peaks. The model tends to see steep peaks, such as many volcanic cones on Rotuma, as ridges (Bowen and Mortensen 1996). This would suggest that wind speeds in the wind maps are exaggerated for peaks. The model has also been found not to model channelling effects through valleys and ravines very well.

Taking the known limitations into account, the windmaps give a good understanding of wind patterns and the wind power potential on Rotuma.

The modelled data indicates that actual wind speeds in many locations on Rotuma are significantly higher than previously available data and data from the weather station suggested.

In the context of this thesis, the wind maps are used as a basis for simulating wind turbine performance. The baseline wind data file is the open-sea atlas file for 2003, and the same file is used for all modelled locations on the island. The wind maps are used in order to determine average wind speeds in locations of interest. These average wind speeds represent scaling factors for the simulation, i.e. the atlas file is scaled in order to the annual average in a particular location.

Table 6.3: Monthly average daily sunshine hours at Ahau, Rotuma.

	2000	2001	2002	2003	2004	2005
January	4.79	5.92	6.53	5.73	4.96	-
February	6.31	6.61	4.88	6.31	5.39	-
March	5.59	4.43	6.76	6.48	6.00	-
April	5.93	6.75	6.86	6.60	6.30	-
May	6.42	6.11	6.63	7.72	9.03	-
June	7.88	5.12	5.94	5.53	6.28	-
July	6.62	6.44	5.17	6.50	6.17	6.15
August	7.97	6.32	6.20	7.14	7.04	5.95
September	7.56	6.08	6.66	7.35	6.38	7.91
October	7.18	7.28	5.55	6.58	5.93	6.56
November	5.80	7.36	5.47	5.83	6.23	5.96
December	3.92	6.35	5.69	4.89	-	5.17

The table is based on sunshine records by the Department of Metereology, Fiji.

### 6.3 Solar Resources

The solar energy potential on Rotuma is estimated on the basis of sunshine hour data for the years 2000 to 2005. Data has been recorded at the weather station at Ahau using a Campbell Stokes sunshine recorder (Figure 6.19(a)). Monthly average daily sunshine hours,  $\bar{n}$ , are shown in Table 6.3. Monthly average irradiation,  $\bar{H}$ , has been estimated using Page's (1964) modified Angstrom type regression equation

$$\bar{H} = \bar{H}_0 \left( a + b \frac{\bar{n}}{\bar{N}} \right), \quad (6.1)$$

where  $\bar{H}_0$  is the radiation outside the atmosphere for the same location, averaged over the month in question,  $a$  and  $b$  are location constants, and  $\bar{N}$  the monthly average maximum possible daily hours of bright sunshine. Constants  $a$  and  $b$  are chosen according to Beckman (1980) for a tropical forest climate and broadleaf evergreen vegetation as  $a = 0.28$  and  $b = 0.39$ .  $\bar{H}_0$  is calculated as

$$\begin{aligned} \bar{H}_0 = & \frac{24 \cdot 3600 G_{sc}}{\pi} \left( 1 + 0.033 \cos \frac{360n}{365} \right) \\ & \cdot \left( \cos \phi \cos \delta \sin \omega + \frac{2\pi\omega_s}{360} \sin \phi \sin \delta \right), \end{aligned} \quad (6.2)$$

where  $n$  is the number of the average day of the month,  $\delta$  the declination for the mean day of the month,  $G_{sc}$  the solar constant of  $G_{sc} = 1353 W/m^2$ ,  $\phi$  the latitude of  $\phi = -12.3$  for Rotuma, and  $\omega_s$  the sunset hour angle. Values for  $\delta$  and

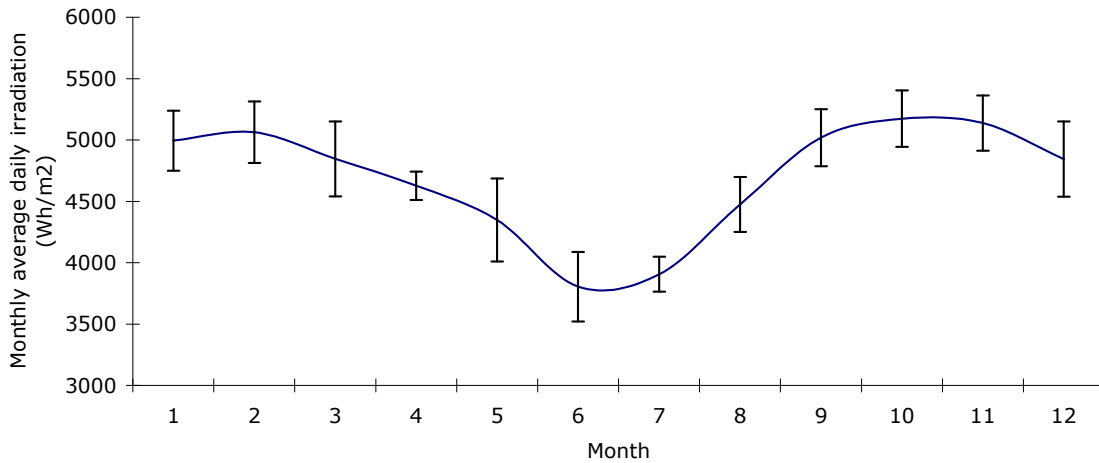

Figure 6.18: Monthly average daily solar irradiation; values are mean values of the years 2000 to 2005 with standard deviations.

$n$  are tabulated in Beckman (1980), and  $\omega_s$  is calculated as

$$\cos\omega_s = -\tan\phi \tan\delta.$$

The resulting monthly average solar irradiation values for the horizontal surface are shown in Figure 6.18.

The accuracy of the method strongly depends on the match of climate and vegetation constants (Beckman and Duffie 1980). However, 20-day irradiation records on the island in 2006, using a Licor LI-200SA pyranometer, were in close agreement with the estimated data. For the period of measurements, the pyranometer was mounted horizontally, in an unshaded position on top of the existing 10m mast of the Rotuman weather station (see Figure 6.19(b)). Data were recorded in 1min increments.

For the period from April 5, 2006 to April 25, 2006, the Rotuma weather station records averaged 8.4 hours per day. The irradiation records from the Licor pyranometer averaged  $5341Wh/m^2$  per day over the same period. The daily average irradiation, as calculated using the equations and constants above, resulted in  $5221Wh/m^2$ , a value 1.88% lower than the measured value. Unfortunately, the 20-day period in April is the only period that both, irradiation data and sunshine hour data was available for.

While 20 days worth of records are not sufficient for a global statement about the accuracy of the estimated data, it does increase confidence that the estimation is a close match. It needs to be noted that the estimates are based on six years of data. Longer term data needed to be consulted prior to the actual system design phase; several decades worth of sunshine hour data are commercially available from the Fiji Department of Meteorology.



(a) Campbell Stokes sunshine recorder at the weather station on Rotuma.



(b) Licor LI-200SA pyranometer, temporarily mounted on top of the Rotuma weather station's 10m anemometer mast, as part of the 2006 energy survey.

Figure 6.19: Instruments at the Rotuma weather station.

# Chapter 7

## Rotuma Case Study

This chapter applies the research method of Chapter 3 to the regional energy system of Rotuma. The initial step of the method, the energy survey was carried out as part of the field study on Rotuma. The results of this are presented in Chapters 4 through 6. This chapter follows the case study through the next four steps of the method, step two, three, four, and five. Sections 7.1 to 7.3 mark step two of the research method and describe four reference built environments in accordance with the four levels of aspiration identified in the survey. These sections attain three characteristic electricity load curves and six potential energy supply options. The result is 18 possible reference energy systems which proceed to modelling and analysis in the subsequent sections. Sections 7.4 through 7.7 set out the modelling approach, defining the modelling parameters as well as feasibility and risk analysis criteria and rankings. Analysis results, marking steps three, 4, and 5 of the research method are described in Sections 7.10 through 7.12. The chapter concludes with a summary of results in Section 7.13.

### 7.1 Reference Built Environments

This section introduces four ideal built environment concepts, herein referred to as reference built environments. The reference built environments frame the full spectrum of peoples' personal development aspirations. The peoples' aspirations were surveyed, and four distinct built environments identified and included in the survey form in Figure 5.3. These four reference built environments are the basis for subsequent energy systems analysis. This section details key aspects of the reference built environments of the survey form in five categories: The *transportation system, housing and lifestyle, the economy, energy and electricity* as well as *public utilities*. The descriptions are more illustrative than restrictive; the purpose is to draw a picture of ways of life. The below descriptions are used as a basis for determining characteristic electricity demands and load curves in subsequent sections.

### **7.1.1 Level A - Back to Tradition**

This concept represents the lowest level of energy service. Only a few low-cost, high utility gadgets are maintained on the island. Advances in energy service are reversed and people live in a way similar to their ancestors, perhaps one hundred years ago.

#### **Transportation**

Access to the island is limited to unscheduled ships calling onto Rotuma. There is no scheduled sea or air travel. It is possible that strategic trading missions are carried out by Rotumans using re-invented traditional sailing canoes.

The road infrastructure is no longer maintained and no motorized vehicles remain in use on the island. Transport of people and goods is by foot, by bicycle, by carts, and by traditional canoes.

#### **Housing and Lifestyle**

New houses are built in traditional ways, or in part-Western ways using only indigenous resources. People live a traditional lifestyle without most Western commodities. People are poor in monetary terms but rich culturally.

#### **Economy and Labor Market**

There is no cash economy. Negligible amounts of indigenous products are exported in exchange for useful imports such as knives, cooking pots, cordage, etc. Trade takes place on boats calling onto Rotuma or by Rotumans sailing to neighboring islands such as Fiji, or Futuna.

There is no labor market per se. According to traditional land rights, everyone has access to land and sea resources in order to provide for family and relatives. Special roles are taken by chiefs and church ministers, who are supported by the communities. Monetary salaries do not exist.

There is no organized tourism but yachts do occasionally call on the island.

#### **Energy and electricity**

Traditional energy uses are firewood for cooking and coconut oil for lighting. Firewood is plentiful on Rotuma; coconut husks are most conveniently used. Coconut oil for lighting is extracted from coconut cream and the water separated through evaporation. Traditional coconut lamps are made from giant-clam shells or coconut shells, with wicks made from processed coconut fibres.

There is no electricity infrastructure and electricity is generally not used.

## **Public Utilities**

A radio link is set up for communications between Rotuma and Fiji. The radio is set up in a central location on the island, the way it used to be before the telephone satellite link was established on Rotuma. There are no phones.

There is no running water supply and no sewage system on the island. Water is obtained from rain water collection, or scooped out of village wells.

The education system reverts to the traditional system of indigenous education. As an option, Western education can be attained by a few students a year, by the resident churches. There is a small nursing station on the island relying on supplies traded by passing ships, but most health problems are solved the indigenous way.

### **7.1.2 Level B - Present Service Level**

By and large, the built environment is the existing built environment. Improvements are allowed, where the service level remains the same. Reliability and other issues with the present situation are considered resolved in this reference built environment case. The most important features of the reference version of the current system are summarized below.

## **Transportation**

Transport to and from the island is by a scheduled monthly boat service to Fiji and by scheduled bi weekly passenger flights to Suva.

On-island transportation is by foot and bicycle, as well as by 3 public buses and private motorized vehicles. Some outboard boats provide local sea transport for fishing and access to outlying islands.

## **Housing and Lifestyle**

Houses are a number of simple concrete constructions as well as part-traditional houses.

Peoples are involved in a combination of subsistence farming and semi Western occupation. Western influences are apparent in the use of selected Western products, but not in cultural activities.

## **Economy and Labor Market**

A number of retail shops exist around the island, stocking groceries, fuels, as well as a small selection of basic household utensils.

Perhaps 10% of the adult populations find employment with various government entities. Few people are employed with the few local companies. Roughly 5% of families are involved in the out-of-the-window retail industry.

Other sources of income, mostly on demand, are copra cutting and the home-manufacture of crafts.

The largest portion of the cash flow comes through remittances or presents from overseas family members.

There is no organized tourism, but a small number of hostels exist.

### **Energy and Electricity**

The main energy use is in the transportation sector. Cooking fuel is done partly on wood fires and partly on kerosene or LPG stoves.

Electricity is available with limitations on allowable types of appliances. Mini grids are installed in 16 places around the island. Mini grids typically serve one or two adjacent villages, and provide electricity to an average of 30 households.

### **Public Utilities**

A telephone network with satellite link to Fiji is available to all households. Fax machines are operable, but the bandwidth is not sufficient for internet access.

A pumped water supply is maintained around the island. Three pumping stations in the interior lift water from the aquifer under Rotuma. Two pumping stations are in continuous operation, and the third station is on standby in case the other system fails. Running water is available for 24hrs/day.

Four primary schools and a high school provide for Western primary education with English language training of the Youth.

A small rural hospital including a dentist, provides for all health care needs on Rotuma.

## **7.1.3 Level C - Intermediate Service Level**

In this moderately developed concept for Rotuma, people live a Western way of life with constraints.

### **Transportation**

Transportation to Fiji is by scheduled bi-weekly boat services and two passenger flights a week.

Intra island transportation is by private motor vehicles and public transport. The main roads around the island are sealed. Several households have motorized outboard boats.

### **Housing and lifestyle**

People live in improved concrete houses. Traditional houses are used for special purposes, but not as principal living spaces. Houses are larger in size than at



present, with additional rooms and more privacy.

The lifestyle is Western, with a number of features from Rotuman culture. A broader, but still limited range of Western appliances is used.

### **Economy and labor market**

All families are involved in the cash economy. At least one person in every household has a permanent part or fulltime job. Some people still grow a lot of their food themselves. However, all foods are also available for sale. Primary economic products are handicrafts, and refined coconut derived goods. Small scale tourism plays a central role in the economy. Manufacturing is on a cottage industry scale.

### **Energy and electricity**

Electricity is available for 12 hours a day. The central electricity system is based on an 11kV grid which encompasses the whole island.

### **Public utilities**

A telephone network with satellite link to Fiji is available to all households. The bandwidth allows the use of fax machines and dial up internet access. Internet access may be realized by a central library.

A pumped water supply is maintained around the island. Three pumping stations in the interior lift water from the aquifer under Rotuma. Two pumping stations are in continuous operation, and the third station is on standby in case the other system fails. Running water is available for 24hrs/day.

Four primary schools and a high school provide for Western primary education with English language training of the youth.

The small rural hospital including dentist, as well as practices in the larger villages provide for the health care needs on Rotuma.

## **7.1.4 Level D - Western Energy Service Level**

Rotuma is fully developed in a Western sense, and people live a fully Westernized lifestyle. Rotuma's economy is focused on a few niche markets in order to compensate for inherent disadvantages due to isolation and small population. This concept might require independence from Fiji.

### **Transportation**

There are weekly boat services to the island; daily flights are available to Fiji, and perhaps nearby international destinations. The wharf widened and the airstrip sealed.

Domestic transport occurs by private vehicles, and public transport. Many people operate private recreational boats and most fishing is done by outboarders. Industrial fishing may be done by local trawlers. The main roads are sealed and offer two lanes. Roads are widened and parking lots are provided at the main work and shopping destinations.

### **Housing and lifestyle**

Modern houses are constructed in timber frames, concrete or other modern building materials. Some traditional style houses may be maintained for special functions.

Rotuma finds itself in a cash economy, almost everyone works a standard 40 hour week. Occasionally private vegetable gardens are maintained on a hobby basis for some food and minimal local supply to markets. However, the bulk of food is imported and acquired from supermarkets.

### **Economy and labor market**

Rotumans are fully engrained in a cash economy; at least one person per household has full time employment to earn money for the family.

Rotuma is exploiting niche markets, using local resources for maximum profits. The island produces highly-priced crops in plantations. A small portion of the diet is supplied by vegetable and local food production, sold on markets. Rotuma's rich marine resources are exploited by the local fishing industry. Rotuma is regulating its own Exclusive Economic Zone (EEZ). Tourism is provided with a special market focus on rich Western tourists; perhaps, the Marriott hotel project that is proposed by Fijian investors could be beneficial for Rotuma when fully developed. Other industries that take advantage of Rotuma's isolation or unique resources may, for example include the banking sector, the fishing and cosmetics industries.

### **Energy and electricity**

A central grid provides energy services as demanded by the economy. Electricity services include a standard range of modern appliances found in Western households. Full or part air conditioning is used by many households and at workplaces.

### **Public utilities**

A telephone network with cable link to Fiji is installed. The bandwidth allows for unlimited use of networking and internet access.

A pumped water supply is maintained around the island. Three pumping stations in the interior lift water from the aquifer under Rotuma. Two pumping

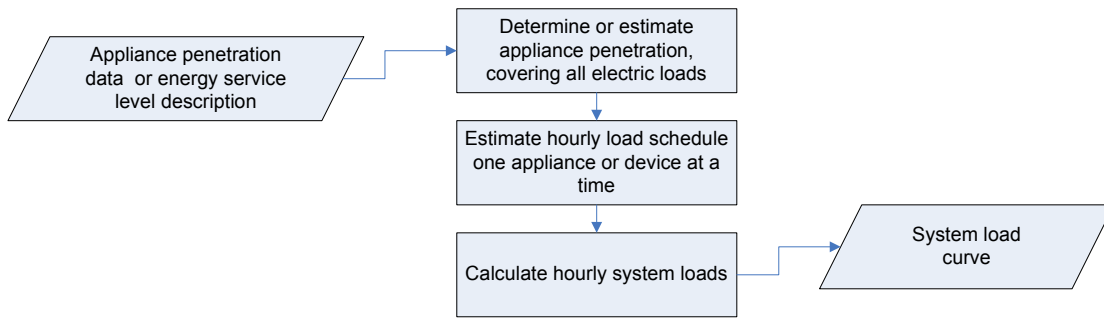

Figure 7.1: Method for determination of generic system load curves.

stations are in continuous operation, and the third station is on standby in case the other system fails. Running water is available for 24hrs/day.

Four primary schools and a high school provide education. The high school offers all levels up to qualification for university entrance. Kindergartens and daycare service are also installed.

A small hospital with modern equipment provides an advanced standard of health care services on Rotuma.

## 7.2 Reference Energy Demands

In this section reference energy demands are developed for each energy service level. The objective is to generate generic electricity load curves that can be used as input for modelling the performance of all energy system options. For the simulations, noise is later applied to these generic load curves. The method for calculating the load curves is overviewed in Figure 7.1. As mentioned above, there is no electricity use in the system A option, the traditional society. For level B actual appliance penetration data is used for computing the loadcurve. Appliance penetration data for levels C and D are estimated and attempt to represent the service level descriptions in Section 7.1. Hourly load schedules were independently determined for each appliance or subcategory of loads. To obtain the system load curve, all single appliance load schedules were added together. The electricity distribution efficiency is included in the load curves.

### 7.2.1 Level B

The electricity demand for energy service level B consists of the domestic village level grids. The energy demand is modelled for the village grids.

In the present system, the electricity demand varies from village to village. Mini-grids supply between ten (Losa) and fifty (Motusa) households. It is assumed that the grids remain as they are. For simplicity, a model village of average

Table 7.1: Option B; load schedule.

Appliance	Schedule $x_h$			
	18:00	19:00	20:00	21:00
Lights	0.70	0.90	0.90	0.85
Washing machines	0.30	0.50	0.33	0.00
Clothes irons	0.05	0.08	0.05	0.02
Freezers	1.00	1.00	1.00	1.00
Radios	0.55	0.88	0.88	0.50
TVs with DVD players	0.40	0.50	0.54	0.54

size is taken as basis for modelling. Whole system conclusions are drawn by multiplying the model data by 18, i.e. the number of individual grids. The average village has a population of 140, living in 27 households. The appliance penetration pattern is identified in Table 7.2. The hourly system load per appliance ( $P_{s,u,h}$ ) is calculated from appliance penetration ( $x_{ap}$ ), the load schedule is expressed by means of the fraction of appliances in use at any particular hour  $x_h$ , and the load per unit  $P_u$ :

$$P_{s,u,h} = x_{ap} x_h n_{hh} P_u , \quad (7.1)$$

where  $n_{hh}$  is the number of entities (e.g. households) per village. The load schedule for the level B energy system is shown in Table 7.1.

The total hourly system load ( $P_{s,h}$ ) is calculated by summing up the hourly contributions of all appliances:

$$P_{s,h} = \frac{\sum_{i=1}^n P_{s,h,u}}{\eta_d} , \quad (7.2)$$

where  $n$  is the total number of different appliances, and  $\eta_d$  is the distribution efficiency. Electricity is, in this case, available for four hours per day. The resulting reference hourly load curve is shown in Figure 7.2. The modelled load level is comparable to recorded current system loads on the island (see Chapter 5).

## 7.2.2 Level C

Energy level C marks the leap from separate village mini-grids to a central electricity grid for the whole island. The central grid is an 11kV system, with the current feeder pillar installations being upgraded to transformer stations. Transformer stations supply single phase 240V connections for two to ten households per station. The grid serves domestic, commercial, and government loads. Electricity is made available in two blocks for a total 12 hours per day, from 8am until

Table 7.2: Option B; domestic reference appliance penetration.

Appliance	Penetration $x_{ap}$	Power <sup>a</sup> $P_u$
Lights	3.0	18W
Washing machines	0.15	150W
Clothes irons	0.4	1000W
Freezers	0.1	150W
Radios	0.6	18W
TVs with DVD players	0.2	90W

<sup>a</sup>per unit

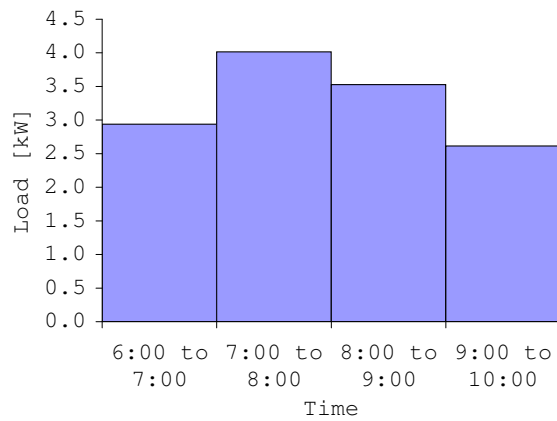

Figure 7.2: Option B; domestic reference load curve of average village of 27 households.

Table 7.3: Electricity consumer entities as in service level C.

Entity	Quantity
Households	480
Retail outlets	60
Cottage industry businesses	80
Commercial farms	20
Schools	4
Hospital	1
Pumping stations <sup>a</sup>	3
Government station	1

---

<sup>a</sup>Public water supply

3pm, and from 6pm through 11pm. The number of units for each load entity is given in Table 7.3.

Domestic and commercial appliances penetrations and respective power consumptions are given in Table 7.4. For simplification, commercial appliances and devices of similar functions are grouped into categories. For instance “small industrial machines” is one category which includes a large variety of machines and is assigned an average power consumption value. Government loads are treated in a similar way by treating different government entities as cumulative single loads. Government loads are listed in Table 7.5.

Appliance penetration is significantly increased compared to service level B. However, appliance penetration still reflects the limited 12-hours electricity supply and is low by Western standards. Air conditioning is not used in this scheme.

The load curve (see Figure 7.3) is calculated from appliance penetration data combined with the load schedule. Hourly load schedules for the total 12 hours supply, Monday through Friday, are determined from equations 7.1 and 7.2 (see 7.6).

Table 7.4: Domestic and commercial appliance penetration basis for service level C.

Appliance (domestic)	Penetration $x_{ap}$	Power <sup>a</sup> $P_u$
Lights	2.0	36W
Washing machines	0.7	200W
Clothes irons	1.0	1000W
Fans	0.8	90W
Refrigerators	0.4	120W
Freezers	0.3	102W
Radios	0.9	20W
TVs with DVD players	0.8	90W
Appliance (commercial)	Penetration $x_{ap}$	Power $P_u$
Lights	4.0	36W
Freezers	0.1	120W
Power tools	1.2	500W
Small industrial machines	0.8	1000W
Welders	0.25	3000W

---

<sup>a</sup>per unit

Table 7.5: Level C - government loads.

Entity	Maximum system load <sup>a</sup> $P_u$
Schools (total)	12.7kW <sup>b</sup>
Hospital	11.0kW <sup>c</sup>
Pumping stations <sup>d</sup>	2 × 3.0kW <sup>e</sup>
Government station	35.0kW <sup>f</sup>

<sup>a</sup>Theoretical load if all devices were running at the same time.

<sup>b</sup>This value is composed of power use for lighting, administration, and HVAC for the high-school and four primary schools.

<sup>c</sup>This value assumes a 40% increase in energy consumption over the current consumption as surveyed.

<sup>d</sup>Public water supply

<sup>e</sup>The 3kW value is an average value for pumping power. The total water pumped is 90l per day per household which is equal to 2/3 of the recent water consumption of Suva (Dawe 2001).

<sup>f</sup>This value represents a 43% increase in power consumption over the level B value.

Table 7.6: Level C; load schedule.

Equipment	Schedule $x_h$												
	8:00	9:00	10:00	11:00	12:00	13:00	14:00	...	18:00	19:00	20:00	21:00	22:00
Domestic													
Refrigerators	1.00	1.00	1.00	1.00	1.00	0.95	0.90		1.00	1.00	0.95	0.90	0.80
Freezers	1.00	1.00	1.00	1.00	1.00	0.95	0.90		1.00	1.00	0.95	0.90	0.80
Lights	0.40	0.30	0.10	0.08	0.04	0.02	0.02		0.40	0.80	0.85	0.80	0.70
TVs&DVDs	0.10	0.10	0.08	0.08	0.08	0.08	0.07		0.15	0.30	0.60	0.60	0.40
Radios	0.40	0.40	0.35	0.35	0.30	0.30	0.30		0.30	0.20	0.10	0.05	0.05
Washers	0.20	0.25	0.20	0.15	0.10	0.05	0.02		0.10	0.05	0.01	0.00	0.00
Clothes irons	0.01	0.01	0.04	0.04	0.03	0.01	0.00		0.04	0.14	0.08	0.02	0.01
Fans	0.10	0.20	0.40	0.40	0.40	0.40	0.50		0.50	0.40	0.20	0.10	0.10
Commercial													
Freezers	1.00	1.00	1.00	1.00	1.00	0.95	0.90		1.00	1.00	0.95	0.90	0.80
El. hand tools	0.10	0.12	0.11	0.10	0.05	0.01	0.01		0.01	0.00	0.00	0.00	0.00
Welder	0.04	0.10	0.10	0.08	0.08	0.03	0.02		0.02	0.00	0.00	0.00	0.00
Machines	0.05	0.14	0.14	0.14	0.14	0.07	0.03		0.02	0.01	0.01	0.01	0.01
Lights	0.15	0.15	0.15	0.14	0.14	0.10	0.10		0.08	0.08	0.06	0.06	0.06
Municipal													
Gov. station	0.60	0.70	0.70	0.70	0.70	0.55	0.10		0.50	0.60	0.50	0.30	0.25
Water supply	1.00	1.00	1.00	1.00	1.00	1.00	1.00		1.00	1.00	1.00	0.00	0.00
Hospital	0.30	0.31	0.31	0.30	0.30	0.25	0.25		0.26	0.24	0.24	0.20	0.17
Schools	0.10	0.10	0.10	0.10	0.10	0.10	0.08		0.02	0.02	0.02	0.02	0.02



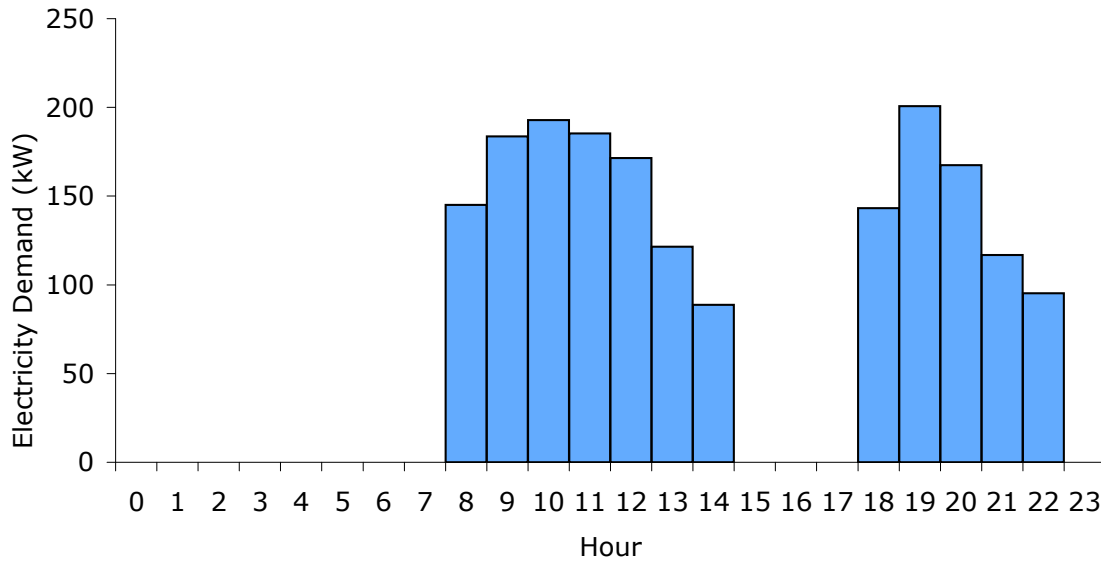

Figure 7.3: Option C; system load curve (weekdays).

### 7.2.3 Level D

Energy service level D uses the same electricity grid as described in the previous section for level C. However, consumption is significantly higher, and electricity is available for 24 hours per day. The number of units for each load entity are the same as for level C and given in Table 7.3.

Domestic and commercial appliances penetrations and respective power consumptions are given in Table 7.7. As before, commercial appliances and devices are treated in categories. Government loads are listed in Table 7.8. Appliance penetration should reflect appliance use patterns in a fully developed Western country of comparable climate.

As in the previous section, the load curve (see Figure 7.4) is calculated from appliance penetration data combined with hourly load schedules (see Table 7.9), according to equations 7.1 and 7.2.

Table 7.7: Domestic and commercial appliance penetration basis for service level D.

Appliance (domestic)	Penetration $x_{ap}$	Power <sup>a</sup> $P_u$ (W)
Lights	6	36
Refrigerators	1	120
Freezers	1	120
TVs&DVDs	0.8	90
Radios	0.9	20
Washers	0.8	100
Tumble dryers	0.3	140
Dish washers	0.4	100
Irons	1	1000
Fans	0.8	90
AirCon	0.7	2000
Kettles	1	2000
Electric stoves	0.1	3000
Vacuum cleaners	0.5	1200
Appliance (commercial)	Penetration $x_{ap}$	Power $P_u$ (W)
Freezers	0.3	120
El. handtools	1.2	500
Welders	0.4	3000
Machines	0.85	4000
Lights	4	36

<sup>a</sup>per unit

Table 7.8: Level D - government loads.

Entity	Maximum system load <sup>a</sup> $P_u$ (kW)
Schools (total)	20.9 <sup>b</sup>
Hospital	55.5 <sup>c</sup>
Pumping stations <sup>d</sup>	$2 \times 3.0^e$
Government station	59.9 <sup>f</sup>

<sup>a</sup>Theoretical load if all devices were running at the same time.

<sup>b</sup>This value is composed of power use for lighting, administration, and HVAC for the high-school and four primary schools.

<sup>c</sup>This value assumes a 40% increase in energy consumption over the current consumption as surveyed.

<sup>d</sup>Public water supply

<sup>e</sup>The 3kW value is an average value for pumping power. The total water pumped is 135l per day per household which is equal to the recent water consumption of Suva (Dawe 2001).

<sup>f</sup>This value represents a 67% increase in power consumption over the level B value.

Table 7.9: Level D; load schedule.

Equipment	Load schedule $x_h$											
	0:00	1:00	2:00	3:00	4:00	5:00	6:00	7:00	8:00	9:00	10:00	11:00
Domestic												
Refrigerators	0.60	0.60	0.60	0.60	0.60	0.60	0.60	0.60	0.60	0.60	0.60	0.60
Freezers	0.60	0.60	0.60	0.60	0.60	0.60	0.60	0.60	0.60	0.60	0.60	0.60
Lights	0.12	0.05	0.05	0.05	0.12	0.24	0.12	0.10	0.10	0.10	0.10	0.10
TVs&DVDs	0.04	0.04	0.03	0.02	0.01	0.02	0.03	0.03	0.06	0.10	0.12	0.12
Radios	0.01	0.01	0.01	0.01	0.01	0.01	0.15	0.20	0.23	0.23	0.23	0.23
Washers	0.00	0.00	0.00	0.00	0.00	0.05	0.10	0.20	0.20	0.18	0.14	0.12
Tumble dryers	0.00	0.00	0.00	0.00	0.00	0.01	0.05	0.05	0.06	0.06	0.07	0.06
Dish washers	0.00	0.00	0.00	0.00	0.00	0.01	0.02	0.04	0.04	0.04	0.03	0.03
Irons	0.00	0.00	0.00	0.00	0.02	0.02	0.03	0.04	0.02	0.02	0.02	0.02
Fans	0.10	0.10	0.10	0.10	0.10	0.10	0.10	0.20	0.30	0.40	0.50	0.50
AirCon	0.10	0.10	0.10	0.10	0.10	0.10	0.10	0.20	0.30	0.30	0.30	0.30
Kettles	0.00	0.00	0.00	0.00	0.00	0.00	0.00	0.00	0.00	0.00	0.00	0.00
Electric stoves	0.00	0.00	0.00	0.00	0.00	0.00	0.01	0.20	0.15	0.01	0.01	0.20
Vac. cleaners	0.00	0.00	0.00	0.00	0.00	0.00	0.01	0.02	0.08	0.09	0.08	0.07
Commercial												
Freezers	0.60	0.60	0.60	0.60	0.60	0.60	0.60	0.60	0.60	0.60	0.60	0.60
El. hand tools	0	0	0	0	0	0	0.02	0.02	0.03	0.03	0.03	0.03
Welders	0	0	0	0	0	0	0.01	0.01	0.01	0.02	0.02	0.02
Machines	0	0	0	0	0	0	0.04	0.04	0.04	0.08	0.08	0.08
Lights	0.1	0.1	0.1	0.1	0.1	0.1	0.1	0.4	0.4	0.4	0.4	0.4
Governmental												
Gov. station	0.05	0.05	0.05	0.05	0.05	0.05	0.05	0.05	0.35	0.35	0.35	0.5
Water supply	1	1	1	1	1	1	1	1	1	1	0	0
Hospital	0.08	0.08	0.08	0.08	0.08	0.08	0.15	0.3	0.45	0.45	0.45	0.5
Schools	0.02	0.02	0.02	0.02	0.02	0.02	0.05	0.09	0.45	0.4	0.4	0.3

Table 7.10: Level D; load schedule - continued

Equipment	Load schedule $x_h$											
	12:00	13:00	14:00	15:00	16:00	17:00	18:00	19:00	20:00	21:00	22:00	23:00
Domestic												
Refrigerators	0.60	0.60	0.60	0.60	0.60	0.60	0.60	0.60	0.60	0.60	0.60	0.60
Freezers	0.60	0.60	0.60	0.60	0.60	0.60	0.60	0.60	0.60	0.60	0.60	0.60
Lights	0.10	0.10	0.10	0.10	0.10	0.10	0.28	0.45	0.45	0.45	0.40	0.35
TVs&DVDs	0.12	0.10	0.10	0.12	0.12	0.12	0.23	0.40	0.45	0.46	0.34	0.28
Radios	0.20	0.15	0.15	0.16	0.20	0.24	0.23	0.14	0.10	0.08	0.06	0.06
Washers	0.08	0.06	0.05	0.04	0.03	0.02	0.01	0.00	0.00	0.00	0.00	0.00
Tumble dryers	0.06	0.04	0.03	0.03	0.03	0.02	0.01	0.01	0.01	0.01	0.00	0.00
Dish washers	0.03	0.03	0.03	0.01	0.01	0.03	0.03	0.05	0.06	0.04	0.03	0.02
Irons	0.01	0.00	0.00	0.01	0.02	0.02	0.09	0.12	0.10	0.04	0.01	0.00
Fans	0.50	0.60	0.60	0.55	0.50	0.45	0.35	0.30	0.20	0.20	0.20	0.10
AirCon	0.30	0.35	0.40	0.40	0.40	0.40	0.40	0.30	0.25	0.20	0.20	0.15
Kettles	0.00	0.00	0.00	0.00	0.00	0.00	0.00	0.00	0.00	0.00	0.00	0.00
Electric stoves	0.50	0.10	0.02	0.04	0.04	0.06	0.20	0.25	0.01	0.01	0.00	0.00
Vac. cleaners	0.06	0.00	0.00	0.00	0.00	0.00	0.00	0.01	0.03	0.00	0.00	0.00
Commercial <sup>a</sup>												
Freezers	0.60	0.60	0.60	0.60	0.60	0.60	0.60	0.60	0.60	0.60	0.60	0.60
El. hand tools	0.01	0	0.02	0.03	0.03	0.03	0.01	0	0	0	0	0
Welders	0.01	0	0.02	0.02	0.02	0.02	0.01	0	0	0	0	0
Machines	0.04	0	0.08	0.08	0.08	0.08	0.04	0	0	0	0	0
Lights	0.4	0.4	0.4	0.4	0.4	0.4	0.2	0.1	0.1	0.1	0.1	0.1
Governmental <sup>b</sup>												
Gov. station	0.5	0.4	0.35	0.36	0.35	0.35	0.1	0.05	0.05	0.05	0.05	0.05
Water supply	0	0	0	0	0	0	0	1	1	1	1	1
Hospital	0.4	0.4	0.5	0.5	0.55	0.5	0.4	0.16	0.16	0.14	0.12	0.1
Schools	0.3	0.3	0.4	0.4	0.4	0.45	0.1	0.02	0.02	0.02	0.02	0.02

<sup>a</sup>These loads are for weekdays. For simplicity, weekend loads are assumed to be 15% of weekdays loads.<sup>b</sup>These loads are for weekdays. For simplicity, weekend loads are assumed to be 10% of weekdays loads.

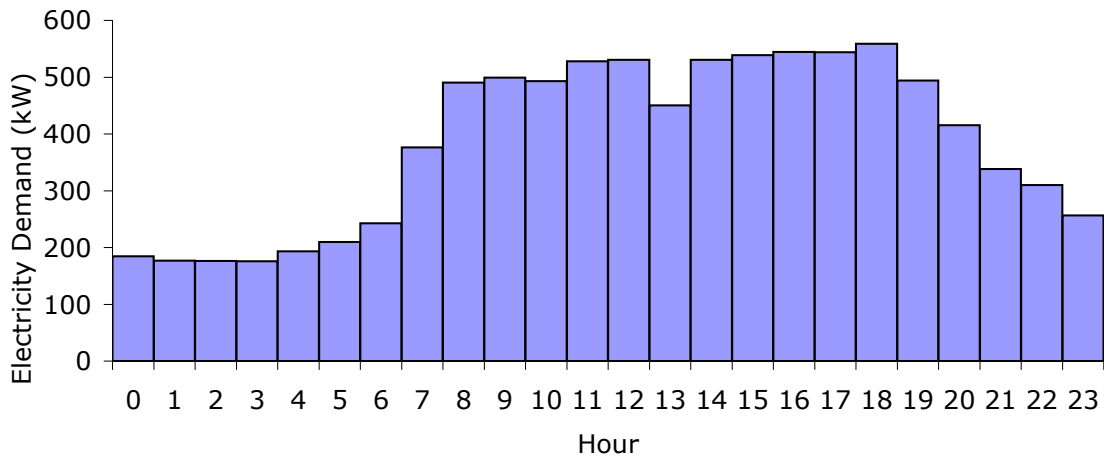

Figure 7.4: Option D; system load curve.

## 7.2.4 Electricity Loads Summary

This chapter led through the process of deriving reference load curves from appliance penetration data, to fit the different built environment options. Level A was left out since there is no electricity. Energy demand data of levels B through D are summarized in Table 7.11.

Table 7.11: Overview table of electrical load characteristics from energy service level B through D.

Parameter	Level B <sup>a</sup>	Level C	Level D
Service hours	4hrs/d	12hrs/d	24hrs/d
Average daily load <sup>b</sup>	13kWh <sub>el</sub> /d	1691kWh <sub>el</sub> /d	8700kWh <sub>el</sub> /d
Peak load <sup>c</sup>	6.8kW <sub>el</sub>	357kW <sub>el</sub>	949kW <sub>el</sub>
	Load modelling parameters		
Daily noise <sup>d</sup>	15%	15%	15%
Hourly noise	15%	15%	20%

<sup>a</sup>Values for level B are for an average village system, not for the whole island.

<sup>b</sup>Values for daily load and peak load already include the transmission efficiency.

<sup>c</sup>The peak load is calculated with the HOMER load curve generator function; inputs are the generic loadcurves and the values for hourly and daily noise as given in this table.

<sup>d</sup>Values for daily and hourly noise are expressed as standard variations

## 7.3 Energy Supply Options

Energy supply options considered are imported Diesel fuel or local resources available on the island. In chapter 6, three renewable energy resources have been identified as promising candidates for implementation on Rotuma: wind, solar, and coconut oil. In order to evaluate the suitability of different energy sources to supply Rotuma's electric loads, these three renewable sources are modelled as well as the non renewable Diesel option. Additionally, two hybrid systems are modelled: combinations of Diesel generation with solar or wind power respectively. In general, hybrid systems are particularly advantageous in energy systems with high solar or wind energy penetration where energy storage is difficult. Thus a total of six energy supply options are modelled. The options are summarized in Table 7.12.

Table 7.12: The energy supply system options used for analysis.

Supply option	Resource	Comments
1	Diesel	-
2	Coconut oil	Shall be produced from local copra
3	Wind	-
4	Wind hybrid	Wind energy penetration $\geq 50\%$
5	Solar PV	-
6	Solar hybrid	Solar energy penetration $\geq 50\%$

While in Diesel and coconut oil generation systems energy is stored in the fuel, external energy storage is essential for wind and solar-PV energy systems. Hybrid wind-diesel and solar-diesel systems of course require no or only minimal energy storage. Pure wind or solar installations can have substantial energy storage requirements. The only proven energy storage for medium and larger size systems is pumped hydro storage, while energy storage for small power systems is usually done by batteries. Exotic options include fly wheels and hydrogen. But fly wheels do not store large amounts of energy and hydrogen technology is not commercially available. Energy storage is generally expensive. For Rotuma the only two options are batteries and pumped storage, however, these incur particular environmental problems.

Batteries contain toxic substances which can be problematic during shipment, installation, and particularly after end-of-life. Pumped hydro storage requires fresh water which is pumped from wells in the interior of the island. Seawater storage might perfectly suit Rotuma but has not been considered as an option because, with only one pilot project realized so far, there are some unknowns and technical issues yet to be solved. Possible leakage of seawater from the upper reservoir into Rotuma's ground water lens would have potentially disastrous

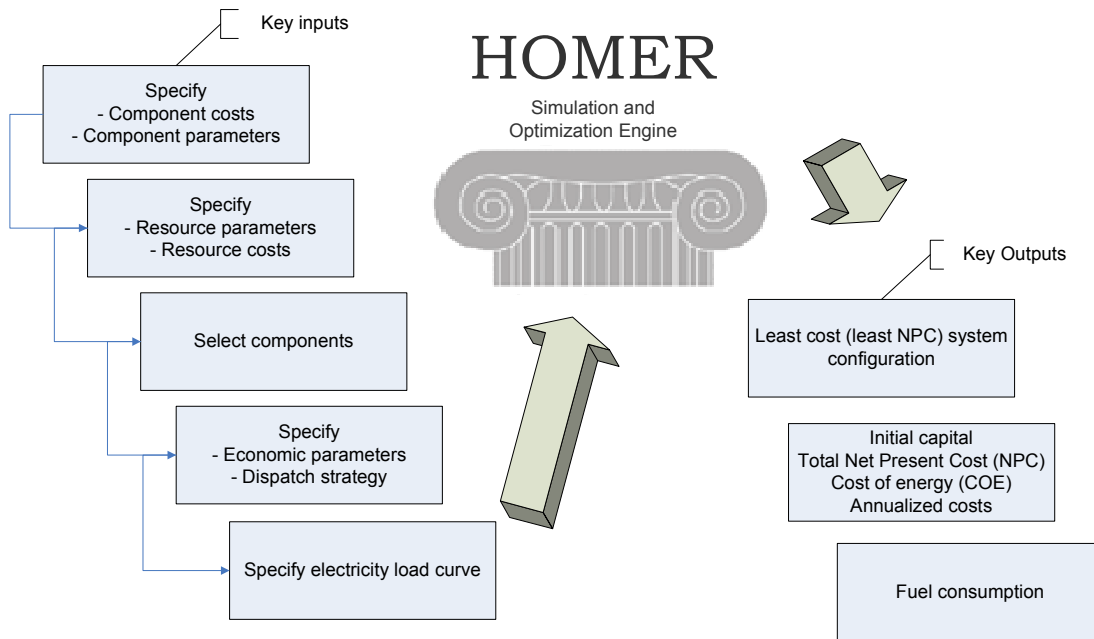

Figure 7.5: Overview of key in and outputs of the HOMER model.

consequences.

## 7.4 Energy Modelling Methodology

The previous sections identified four energy service levels and six energy supply options. Since service level A dispenses with electricity, only levels B, C, and D need be modelled (a total of 18 energy systems). The energy systems are modelled and optimized using the HOMER modelling platform. Key modelling in- and outputs are shown in Figure 7.5. In order to assure consistency in modelling across the range of concepts, the modelling parameters and cost assumptions are established in advance, and specified in the next section. The same assumptions are used for all models.

HOMER's simulation outputs include various costs, fuel consumption, and energy production data. The optimization output is a list of the least cost system configurations for all feasible technology combinations that were selected to be considered. The optimization parameter is the system's net present cost (NPC), and in HOMER all feasible energy systems are ranked by this value. The NPC is defined as:

$$C_{NPC} = \frac{C_{a,tot}}{CRF}, \quad (7.3)$$

where  $C_{a,tot}$  stands for the total annualized cost and  $k_{CRF}$  is the capital recovery



factor:

$$k_{CRF} = \frac{i(1+i)^n}{(1+i)^n - 1}, \quad (7.4)$$

where  $i$  is the real interest rate (the interest rate minus inflation rate), and  $n$  the project life in years. The project life has been set to 25 years in the context of this study. For financial analysis, the general assumption is that all capital investments and component replacement costs are debt funded. The interest rate was set to 8.5%. With an inflation rate of 2.5%, the real interest rate is  $i = 6.0\%$  which is the value used for modelling. The total annualized cost ( $C_{a,tot}$ ) is the sum of annualized capital cost, annualized replacement cost, annual O&M cost and annual fuel cost.

Additional costs used for comparison of the concepts are the cost of energy (COE) and domestic energy cost (DEC). The COE is the average cost per kWh of electrical load served  $E_s$ .

$$C_{COE} = \frac{C_{a,tot}}{E_s}. \quad (7.5)$$

The DEC is the average monthly energy cost to an average household, defined as

$$C_{DEC} = k \frac{C_{a,tot}}{12 n_{hh}}, \quad (7.6)$$

where  $n_{hh}$  is the number of households connected to the grid, and  $k$  the ratio of electric load served to households over the total electric load served (households, municipal loads, and business loads).

## 7.5 Modelling Parameters

This section specifies all parameters needed for modelling the 18 reference energy systems. Components include electricity grid extensions and all power supply system components. System component costs are either constant or size-dependent. If costs are not constant, costs for two or three sizes are put in. Costs for in-between sizes are interpolated by the software. The numbers given below are used as direct inputs for the HOMER models.

### 7.5.1 Electricity Grid

Almost all villages on Rotuma have mini-grid installations in working order; all are 240V grids. These mini-grids are used for low voltage end user distribution in all concepts, and it is assumed that no investment is required to make these useable. Thus the capital cost for installing the grid is zero for all B-level concepts. C- and D-level concepts require an additional new island wide grid.

Table 7.13: Breakdown of electricity grid costs.

	Qty.	Unit cost	Total
Grid, installed cost	32 (km)	F\$50,000	F\$1,600,000
Energy meters, domestic and commercial	530	F\$100	F\$53,000
Step up transformer	1	F\$50,000	F\$50,000
Domestic step down transformers <sup>a</sup>	54	F\$2000	F\$108,000
Commercial step down transformers	15	F\$4500	F\$67,500
Total			F\$1,878,500

<sup>a</sup>Three per village.

The grid shall be a standard 11kV grid, which ties into the substations of the existing village grids via three step down transformers per village. Grid costs including all supplies, labor and shipping are assumed to amount to F\$50,000 per kilometer, based on an estimate by energy consultants in Fiji, documented in (BURGEAP 2006). A total length of 32km is sufficient to connect all villages and the three pumping stations. Additional allowances were made for transformers and end user meters. The analysis uses a fixed capital cost of F\$1,878,500 and an annual operation and maintenance cost of F\$15,000. Costs are broken down in Table 7.13.

### 7.5.2 Diesel Generator Sets

Diesel generator costs were estimated on the basis of quotes by two different New Zealand suppliers. Installed costs are given in Table 7.14. For operation and maintenance (O&M) costs, it was assumed that 5kW and 10kW units are operated by untrained villagers, but 100kW units and above are operated and maintained by trained mechanics. Generator costs for units of 100kW and larger include costs for expensive power control and synchronization equipment. In the model, all generators have an expected lifetime of 50,000 hours, and operate with a minimum load ratio of 20%. It is also assumed that all generators have the same fuel efficiency curve, with an interception coefficient of  $0.08l/hr/kW_{rated}$  and a slope of  $0.25l/hr/kW_{output}$ . These values translate into a fuel efficiency of 32% at peak load. While this is a realistic assumption for larger generators, many smaller generators show somewhat lower fuel efficiencies. Nevertheless, for the modelling purposes at hand the above fuel efficiency curves are sufficiently accurate. In case coconut oil is used as generator fuel, some modifications to the generator

Table 7.14: Generator cost parameters.

Size	Installed cost	O&M
5kW	F\$5266.00	0.20F\$/h
10kW	F\$13,044.00	0.30F\$/h
100kW	F\$70,598.00	10.00F\$/h
600kW	F\$233,925.00	20.00F\$/h

are required. As a simplification it is assumed that these modifications add 10% to the generator capital costs and increase O&M costs by 100% . These values are conservative estimates because afflicted with uncertainty; real costs are hard to determine, because engine conversions are not currently standardized. The 100% increase in O&M costs was chosen on the basis of discussions with energy planners from SOPAC.

### 7.5.3 Generator fuels

Two generator fuels are modelled, standard Diesel fuel and coconut oil. At the time of the survey, the price of Diesel fuel on Rotuma was F\$1.85/l. This fuel price is used for modelling all systems. It certainly may be possible that a larger utility company, such as for level D could negotiate lower fuel prices, however, at this stage this would be speculation and has been disregarded in the models.

Precondition for the use of coconut oil is that it be produced on the island. The cost of coconut oil is comprised of two parts: the cost of the raw material and production cost. Dried copra (coconut flesh) is currently exported by Sister's Enterprises of Rotuma for F\$0.4/kg. At an oil yield of  $0.6l/kg_{dry}$ , the raw material portion of the coconut oil cost becomes F\$0.67/l. Production costs are evaluated at concept level and are summarized in Table 7.15. For modelling purposes it is assumed that a coconut processing plant with all incurred costs is part of the power plant operation. The total capital and O&M cost shown in Table 7.15 is added to fixed power plant cost in HOMER.

Table 7.15: Costs of copra processing plants.

Level >		B		C		D	
Capacity	Annual	40,000l		250000l		1250000l	
	Daily	154l		962l		4808l	
	Item	Capital Cost	O&M	Capital cost	O&M	Capital cost	O&M
Equipment	Facilities	F\$15,000	F\$ 120	F\$ 150,000	F\$ 1,000	F\$ 400,000	F\$ 1,600
	Nut shredder	F\$ 8,000	F\$ 500	F\$ 40,000	F\$ 1,000	F\$ 90,000	F\$ 2,000
	Screw press	F\$24,000	F\$ 200	F\$ 120,000	F\$ 1,400	F\$ 280,000	F\$ 2,500
	Filtering equipment	F\$ 8,000	F\$ 1,500	F\$ 35,000	F\$ 3,000	F\$ 89,000	F\$ 5,000
	Lab equip-ment	F\$ 800	F\$ 200	F\$ 4,000	F\$ 400	F\$ 6,000	F\$ 600
Labor	Qualified operators	-	-	(1 person)	F\$ 35,000	(1 person)	F\$ 35,000
	Semiskilled operators	(1 person)	F\$11,000	(3 persons)	F\$ 33,000	(6 persons)	F\$ 66,000
Totals		F\$55,800	F\$13,520	F\$ 349,000	F\$ 74,800	F\$ 865,000	F\$ 112,700

### 7.5.4 Photovoltaic Systems

Cost estimates for solar photovoltaic (PV) systems are based on quotes by Clay Engineering of Fiji and by Gaiam<sup>®</sup> Real Goods. Installed system costs as used for modelling are shown in table 7.16. These values include PV panels, maximum power point tracker (MPPT) controls, mounting hardware, wiring, and installation. The PV system lifetime is assumed to be 15 years, with a PV derating

Table 7.16: Photovoltaic systems cost parameters

Size	Installed cost	O&M
1kW	F\$18,440.00	1000.00F\$/a
10kW	F\$164,400.00	6000.00F\$/a
100kW	F\$1,440,000.00	40,000F\$/ha

factor of 90%. No tracking systems are employed. All panels are installed with an azimuth angle of 180°. Ground reflectance is assumed to be 20%.

### 7.5.5 Wind Turbines

Wind turbine prices were modelled on the basis of list prices of commercially available turbines. Costs include costs for turbine, tower, turbine controls, wiring, shipping, and installation. Transport and installation costs need be considered as crude estimates, for real transport and installation costs strongly depend on final location and specific turbine. Factors such as terrain and accessibility can shift installation costs by orders of magnitude. The largest turbines considered are 500kW. Turbines larger than this could not be delivered to Rotuma without major upgrades of wharf and road infrastructure at hand. Turbines are modelled as generic turbines with scaled performance curves of exemplary (real) turbines. Turbine costs are modelled on the basis of F\$/kW of rated capacity. Costs used in this model are given in Table 7.17. Costs for smaller turbines reflect an average cost of turbines in this size range, specifically turbines produced by ‘Southwest Windpower’, ‘Bergey’, and ‘Proven’. The installed cost of large turbines is based on the New Zealand ‘Windflow’ turbine of 500kW rated capacity.

Table 7.17: Wind turbine systems cost parameters.

Size	Installed cost	O&M
1 to 20kW	8,820.00F\$/kW	200.00F\$/kW/a
21 to 500kW	3,587.00F\$/kW	100.00F\$/kW/a

For simplification, hub heights are assumed to be 25m for small turbines (1 to 20kW), and 45m for all larger turbines (21 to 500kW). Expected turbine

Table 7.18: Converter systems cost parameters.

Size	Installed cost	O&M
1kW	F\$4,900.00	F\$5/a
10kW	F\$29,400.00	F\$20/a
100kW	F\$245,000.00	F\$100/a

lifetimes are 15 years for small turbines and 20 years for larger ones. This is a reasonable value considering Rotuma's highly corrosive environmental conditions and frequency of hurricanes.

### 7.5.6 Power converters

Solar PV, small wind turbines and battery banks all work with DC electricity. In order to be useable for the island grids, it needs to be converted to AC power by inverters. For this purpose, all inverters must be of the intertwiner type, i.e. be capable of frequency synchronization. Inverters also include rectifier (AC/DC) capability. Costs for inverters (see Table 7.18) are assumed to include costs for transport and installation, and also controlled dump loads. Converter systems are modelled with a constant efficiency of 90% and a system lifetime of 15 years.

### 7.5.7 Battery Systems

All battery banks are assumed to be based on the Trojan, T105 deep cycle batteries. These batteries are available in Fiji at an installed cost of roughly F\$367 per battery<sup>1</sup>. Price reductions resulting from ordering large quantities are assumed to be offset by the cost of constructing dedicated battery housing facilities. The battery lifetime is expressed in lifetime power throughput, and is modelled to be 845kWh. Battery maintenance costs are set to F\$2/a per cell.

### 7.5.8 Pumped Storage

Pumped storage is modelled as a way of storing electricity for larger systems (level D). Due to the lack of any fresh water lakes or rivers on Rotuma, two reservoirs would have to be constructed, at the top and bottom of the plant. A seawater based system has been considered but was discounted for several reasons: the technology is in its infancy, only one pilot project has been completed (Okinawa, Japan). Thus, the proposed way of using pumped storage is the use of two reservoirs and two pump turbines. A volcanic crater can be used as a top reservoir, if lined with non-permeable materials, because the existing rock on Rotuma

<sup>1</sup>Clay Engineering, Suva, Fiji, sells these batteries for F\$352, exclusive any additional costs.

Table 7.19: Pumped storage cost parameters.

Size	Installed cost	O&M
50kW	F\$2,200,000.00	F\$2000/a
100kW	F\$3,800,000.00	F\$3000/a
1000kW	F\$17,800,000.00	F\$9000/a

is extremely porous (Woodhall 1987). The bottom reservoir would have to be constructed with limited use of natural features. Construction costs would be a multiple of other projects with similar power capacities, but exact costs cannot be determined without an in-depth study. As a basis for preliminary costing, costs of different hydro power installations on Fiji are used. Costs of previous projects in Fiji and other Pacific Islands are discussed in (World-Bank 1992) and (Johnston et al. 2004). In this study it is assumed that project costs for a pumped storage plant with two sealed reservoirs is four times the cost of a sole hydro power plant (without lower reservoir and pump) in similar geologies (see Table 7.19). The plant life is set to 25 years.

## 7.6 Risk Assessment Methodology

This section poses preliminary considerations to the risk assessment in context of this study, it sets the ranking scales to be used, and it defines the criteria that are employed for comparing the 18 energy system concepts. Understandably every energy system concept reveals its own set of specific risks. Risks are development issues with no or unpredictable solutions at this point in time. Risks with no solutions are known as development obstacles. If obstacles arise for any concept, this concept is discarded. Perhaps the most common obstacle is economic infeasibility.

First it is important to restate the purpose of this risk assessment; as set out in Chapter 3, the goal of this study is to find regional energy system solutions that are viable in the context of anthropogenic continuity. Most generally speaking the entity at stake is anthropogenic continuity of Rotuma's people. The agency giving rise to this risk is the regional energy system. The context of this study is not a project risk management problem. Thus the main focus is not on finding ways to mitigate risks, but on understanding the risks that are given rise to by different regional energy systems, and to evaluate and compare these one below the other.

A practical way to structure the risk analysis is by some distinctive factors which all contribute to the prospect of anthropogenic continuity. These are: general feasibility, cultural resource security, environmental problems, and cultural dilution.

The ensuing subsections explain these four factors and provide the particular

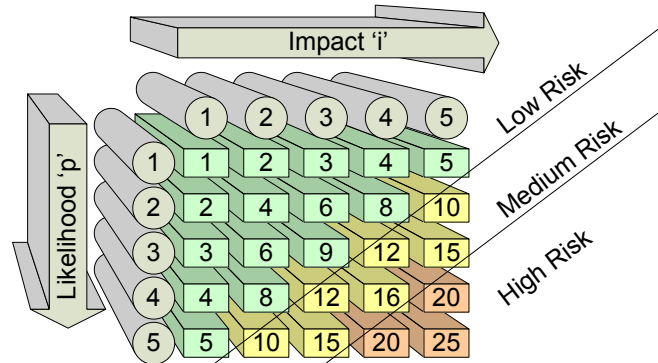

Figure 7.6: Risk matrix, adapted from (Elms 1998).

scales for ranking the risks therein. The risk assessment being qualitative in nature, the scales outlined below are to be understood merely as guidelines. All risks ( $R$ ) are expressed in terms of likelihood ( $p$ ) and impact ( $i$ ) as

$$R = p \times i . \quad (7.7)$$

All ranking scales herein contain five chance and consequence levels. Three risk levels are identified as shown in Figure 7.6. While ranking scales for impacts are different for the different categories of risks and are detailed in the subsequent sections, the scale used for ranking likelihoods of occurrence ( $p$ ) is the same for all categories:

Likelihood of occurrence ( $p$ )	Ranking
Most unlikely	1
Rather unlikely	2
Equally likely & unlikely	3
Rather likely	4
Most likely	5

### 7.6.1 General Feasibility

General feasibility describes a group of risks to fundamental and technical realization of the energy system concepts. General feasibility is broken down into several subheadings:

- **Feasibility issues** refer to issues with the fundamental feasibility of the concept. The system's feasibility is at risk if the need for the product is not clearly recognizable.
- **Fundamental issues** are problems given rise to by the fundamental laws of sciences such as chemistry or the laws of thermodynamics.
- **Technical issues** describe technical problems in architecture, design and manufacture, or technical problems during system operation and controls.



- **Application issues** are problems that may arise from integration into the existing technical and social system.
- **Cost issues** are the most common concept obstacles. If systems are economically viable, the costs become part of the standard risk assessment. Cost criteria used herein are given below.

Risks that arise from feasibility issues are evaluated according to their impacts on the functionality of the energy supply system using the following ranking on a scale from one to five:

Description of impact (i)	Ranking
Minor energy system disturbances, e.g. minor power quality issues or brownouts	1
Minor energy system disruptions, e.g. short blackouts	2
Severe energy system disruptions, e.g. several days of blackouts, financial losses up to 5% of investment, and/or permanent loss of 0 to 20% of energy services	3
Major energy system disruptions, e.g. several days of blackouts, financial losses up to 20% of investment, and/or permanent loss of 20 to 75% of energy services	4
Severe disruptions and system damage, e.g. several days of blackouts, financial losses more than 20% of investment, and/or permanent loss of more than 75% of energy services	5

### 7.6.2 Resource Security

Resource security is evaluated by means of events with potential to disrupt supply chains. Resource security is not only limited to energy resources to drive the power plants, but also involves the supply of system components and materials. As previously stated, the project lifetime is 25 years, and the likelihood of events challenging resource security shall be the likelihood of these occurring within the project life. Below is a list of considered events with their potential of impairing resource security and the likelihoods of these occurring within the project life:

- Doubling of fuel prices, 50% irreversible reduction in fossil fuel supply and as a consequence also 50% reduction of boat trips to the island. The probability of this occurring within the next 25 years is considered most likely (5) (Dantas et al. 2006).
- A major hurricane strikes Rotuma within the project life, a rather likely event (4). Here considered is the event of a class two hurricane with sustained winds of up to 85kn. (See Section 6.1)
- A year with extended periods of intertropical convergence with no power winds for a period of two months or more. The likelihood of this occurring

is set to low (1), although this is an assumption and long term wind data to support this is not available. However, local observations (John Bennett, personal communication) and an expert opinion of a climatologist from the Fiji Meteorological Department (Waisiki Tabua, personal communication) suggest that there is an observable trend towards a Southwards shift of the zone of intertropical convergence. This shift would translate to longer periods without trade winds.

The impacts of resource security risks are evaluated on the same scale as feasibility risks in the previous section.

### 7.6.3 Environmental Damage

The potential impacts of environmental damage is rated on the following scale:

Description of impact (i)	Ranking
Adversely affects well being of present population	1
Adversely affects well being, minor short term health effects on population or minor decline in essential resources	2
Significant short term health effects or minor long term health effects, or significant decline in essential resources	3
Major long term health effects or major decline of essential resources, or some premature deaths	4
Major long term health effects or major decline of essential resources, causing many premature deaths or render Rotuma uninhabitable	5

### 7.6.4 Cultural Dilution

While the three preceding factors obviously affect anthropogenic continuity, the addition of cultural dilution as a factor may need justification. While cultural dilution receives comparably little attention in the subsequent analysis, it is realized that cultural dilution impacts on anthropogenic continuity in two ways: First, a loss of culture results in a loss of indigenous knowledge and therefore compromises the reversibility of extensive development if necessary. Secondly and more importantly, the loss of culture would likely incur a loss of the social structures and social security systems that are ingrained in Rotuma's tradition. For example, at present Rotuma still has an effective redistribution system. If somewhat catches fish, he would be expected to share the catch with people of the village, and particularly those who are not, themselves, able to go fishing. However, in personal interviews some people explained how the introduction of refrigerators caused people to share less and keep their catch for themselves.

Description of impact (i)	Ranking
No modifications to present state of Rotuman culture required	1
Rotuman culture compromised in some aspects of day to day life	2
Rotuman lifestyle is practised by some people, but is not essential	3
Rotuman culture plays insignificant role in day to day life	4
The Rotuman culture plays no role in day to day life	5

## 7.7 Individual Risk Assessment Criteria

The following summary lists all risks that have been identified for any system concept. Some risks apply to most, others only apply to single concepts. General risks that apply to all concepts within a respective energy service level are listed in Table 7.20, and all concept-specific risks are listed in Table 7.21.

### 7.7.1 Concept Independent Risks

Table 7.20: Evaluation criteria for risk assessment - risks common to service level. Likelihoods of occurrence and impacts are listed as “p” and “i”.

Risk description	Evaluation criteria
Service level development opposed by population	p $f$ (Percentage of population opposed); as defined in Section 5.2.5 i Set to “5” for all systems
<i>Fundamental issues</i>	
High cost of supply of goods due to isolation combined with low population	p Set to “4” for all systems i $f$ (Dependence on demand for non-indigenous goods and services)
<i>Environmental issues</i>	
Soil/groundwater contamination through accumulation of old appliance rubbish	p $f$ (No. of appliances, service level); a higher service level is assumed to incur more appropriate rubbish disposal i $f$ (No. of appliances)
<i>Cultural dilution</i>	
Reduction/gradual loss of redistribution custom	p $f$ (No. of freezers, Percentage of imported vs. local foods) i Set to “4” for all systems
Reduction/gradual loss of mutual reciprocity of services	p $f$ (No. of labor substituting appliances) i Set to “5” for all systems

– continued on next page

Table 7.20 – continued from previous page

Risk description	Evaluation criteria	
Reduction/gradual loss of functionality of traditional leadership	p	$f$ (Percentage of imported vs. local goods); imported goods create independence of Rotuman goods and services
	i	Set to “4” for all systems
Reduction/gradual loss of planting and gardening skills	p	$f$ (No. of freezers, Percentage of imported vs. local foods)
	i	Set to “5” for all systems

### 7.7.2 Concept Level Risks

Table 7.21: Evaluation criteria for risk assessment - individual system concepts.

Risk description	Evaluation criteria	
<i>Fundamental issues</i>		
Engine problems due to coconut oil caused corrosion	p	$f$ (Potential fuel quality issues); fuel quality is likely to increase with system size
	i	Set to “3” for all systems
Premature turbine failure due to corrosion in marine environment	p	$f$ (Total exposed equipment, durability), durability assumed to be higher for large commercial turbines
	i	Set to “3” for all systems
Premature PV panel failure due to corrosive marine environment	p	$f$ (Total exposed solar PV areas)
	i	Set to “3” for all systems
<i>Technical issues</i>		
Failure of coconut oil conversion equipment due to non standardization of equipment	p	Set to “3” for all systems
	i	$f$ (No. of plants, service level); problems are harder to track on many small systems and a higher service level means more professional operators
Power quality problems due to high wind penetration	p	$f$ (system capacity); a higher capacity system is assumed to have better power electronics to mitigate quality problems
	i	Set to “1” for all systems
<i>Application issues</i>		
Repair delays due to long turnaround times	p	$f$ (No. of boat trips to the island)

– continued on next page

Table 7.21 – continued from previous page

Risk description	Evaluation criteria
	i $f$ (Energy system complexity, service level); a higher service level means professional plant operators
Damage to plant due to improper use	p $f$ (Plant robustness, service level) i Set to “3” for all systems
<i>Cost issues</i>	
Continuous financing problems	p $f$ (Domestic energy cost); i.e. the cost per household per month; see Sec. 7.7.3 for the relevant cost table i Set to “4” for all systems
Difficulties finding lender due to high initial investment	p $f$ (Initial investment); see Sec. 7.7.3 for the relevant cost table i Set to “5” for all systems
<i>Resource security</i>	
System disruptions by 50% petroleum reduction of petroleum product imports	p Set to “5” for all systems; i.e. the likelihood of peak oil occurrence within project life i $f$ (Petroleum fuel use, system flexibility)
Plant repair difficulties due to 50% reduction of access trips to the island due to peak oil	p $f$ (No. of boat trips to the island) i $f$ (Energy system complexity, service level); a higher service level means professional plant operators
Damage to plant due to hurricane strike	p Set to “3” for all systems; i.e. the likelihood of a hurricane occurring within project life i $f$ (Hurricane robustness of exposed equipment)
Local supply problems due to dramatic rise in world coconut oil price	p Set to “2” for all systems; i.e. the likelihood of a significant increase in world coconut oil price i $f$ (Required copra volumes/tot. copra production); it is assumed that copra would still be provided to the plant at low cost, if volume is small fraction of copra exports
Supply shortage due to hurricane strike	p Set to “3” for all systems; i.e. the likelihood of a hurricane occurring within project life

– continued on next page

Table 7.21 – continued from previous page

Risk description	Evaluation criteria	
	i	$f$ (Required copra volumes/tot. copra production); if req. volumes are low, production outfall can be deducted from copra exports
Wind resource problems due to two months period of missing power winds	p	Set to “3” for all systems; i.e. the estimated likelihood of extended calm periods
	i	$f$ (system flexibility, storage capacity)
Solar resource problems due to three weeks period of no sun	p	Set to “3” for all systems; i.e. the likelihood of extended low sunshine periods
	i	$f$ (system flexibility, storage capacity)
<i>Environmental problems</i>		
Accumulation of old machinery, excl. batteries	p	$f$ (Required amount of equipment)
	i	$f$ (toxicity)
Large scale contamination of soil/groundwater by waste engine oil	p	$f$ (System capacities, system dispersion); smaller distributed systems are assumed cause relatively more problems
	i	Set to “3” for all systems
Soil/groundwater contamination due to petroleum fuel spills on land	p	$f$ (System capacities, system dispersion); smaller distributed systems are assumed cause relatively more problems
	i	Set to “3” for all systems
Sea contamination due to petroleum fuel spills during delivery	p	$f$ (No. of trips, tot. petr. Fuel requirements)
	i	Set to “4” for all systems
Local air pollution due to engine exhausts	p	$f$ (No. of people living near generators); higher for distributed generators than central systems
	i	$f$ (system capacity)
Noise pollution due to plant operation	p	$f$ (Type and size of equipment, plant dispersity); distruted systems affect a greater no. of people
	i	Set to “1” for all systems
Habitat destruction due to land requirements	p	$f$ (Plant space requirements)
	i	Set to “3” for all systems

– continued on next page

Table 7.21 – continued from previous page

Risk description	Evaluation criteria	
Soil/groundwater contamination due to battery spillages	p	$f$ (No. of required batteries, plant dispersion, service level); distributed systems cause greater problems; higher service level is assumed to mean professional operators and thus more appropriate handling
	i	Set to “4” for all systems
Soil/groundwater contamination due to battery dumping	p	$f$ (No. of required batteries, plant dispersion, service level); distributed systems cause greater problems; higher service level is assumed to mean professional operators and thus more appropriate handling
	i	Set to “4” for all systems
Decimation of bird populations due to large wind turbines	p	$f$ (No. and rotor diameter of turbines)
	i	Set to “2” for all systems

### 7.7.3 Economic Viability

The risk to financial feasibility of any concept requires special consideration. It is not uncommon that energy system concepts, while perhaps otherwise attainable are economically not viable due to prohibitive costs. In the Rotuma context, thresholds of prohibitive costs were evaluated on the basis of domestic energy cost (DEC) (see Section 7.4) and set to these values:

	Prohibitive cost
Service level B	$DEC \geq \text{F\$}45$
Service level C	$DEC \geq \text{F\$}100$
Service level D	$DEC \geq \text{F\$}160$

It is assumed that, in the context of the respective energy service levels, monthly electricity fees in excess of the values above would be unmaintainable.

For system concepts with no prohibitive costs, a likelihood of financial problems is evaluated by two factors: DEC and the initial capital investment ( $C_{cap}$ ).

With reference to the list in the previous section, high DEC give rise to the risk titled ‘Continuous financing problems’. Likelihoods of this risk as a function of the energy service level and DEC are suggested as such:

Likelihood	Level B	Level C	Level D
5	$DEC \geq \text{F\$30}$	$DEC \geq \text{F\$120}$	$DEC \geq \text{F\$150}$
4	$DEC < \text{F\$30}$	$DEC < \text{F\$120}$	$DEC < \text{F\$150}$
3	$DEC < \text{F\$20}$	$DEC < \text{F\$80}$	$DEC < \text{F\$125}$
2	$DEC < \text{F\$15}$	$DEC < \text{F\$70}$	$DEC < \text{F\$100}$
1	$DEC < \text{F\$10}$	$DEC < \text{F\$50}$	$DEC < \text{F\$75}$

In the same way and in reference to the same list, the likelihood of the risk 'Difficulties finding lender due to high initial investment' is evaluated in line with the these values:

Likelihood	Level B	Level C	Level D
5	$C_{cap} \geq \text{F\$1m}$	$C_{cap} \geq \text{F\$8m}$	$C_{cap} \geq \text{F\$15m}$
4	$C_{cap} < \text{F\$1m}$	$C_{cap} < \text{F\$8m}$	$C_{cap} < \text{F\$15m}$
3	$C_{cap} < \text{F\$0.5m}$	$C_{cap} < \text{F\$4m}$	$C_{cap} < \text{F\$8m}$
2	$C_{cap} < \text{F\$250k}$	$C_{cap} < \text{F\$2m}$	$C_{cap} < \text{F\$4m}$
1	$C_{cap} < \text{F\$100k}$	$C_{cap} < \text{F\$1m}$	$C_{cap} < \text{F\$2m}$



## 7.8 Risk Analysis Case Example

Previous sections explained the risk assessment method and introduced common ranking scales to be used as guidelines in order to warrant comparability. Before presenting the risk assessment results in the following sections, this section gives a case example of how the risk assessment was performed. This section is to illustrate the methodology more clearly for one case than this is possible for every case. A side effect of this section is to document the way of thinking when the assessment guidelines from before are applied.

The case example is for a B service level configuration (described as no change from present system) with a wind power supply system.

1. In a first step, Table 7.7 all risk factors that apply to the wind supply case are identified. In this case, the applicable risk factors are:

### **Feasibility Risks**

- Premature turbine failure...
- Repair delays...
- Damage to plant due to improper use.
- Continuous financing problems.
- Difficulties finding initial lender...

### **Resource Security Risks**

- Plant repair difficulties...
- Damage to plant due to hurricane strike.
- Wind resource problems...

### **Environmental Risks**

- Accumulation of old machinery.
- Soil/groundwater contamination due to battery spillages.
- Soil/groundwater contamination due to battery spillages.
- Habitat destruction due to land requirements.
- Noise pollution due to plant operation.

2. As second step, the risk items are ranked in terms of impact and likelihood of occurrence. Guidelines for the rankings are in Section 7.7. Scales for evaluating probabilities are tabulated in Section 7.6.

3. After all risks are scored according to impact and likelihood, total risk scores are calculated for each item by multiplying the two scores together. Concepts that involve up to one 'high' risk factor are considered development opportunities.

The scoring of the risk factors is illustrated factor by factor:

### Feasibility Risks

*MB3.1: Premature turbine failure due to corrosion in marine environment.*

As defined in Section 7.6 the impact for this event is 3 in all cases. The likelihood is considered a function of the amount of exposed equipment involved. The durability of equipment is lower for small turbines than for larger ones which could be custom adapted to cope with the highly corrosive environment. However, because the short turbine design life of 15 years already accounts for corrosion, and therefore the probability of premature failure is set to a value of 2.

*AB3.1 Repair delays due to long turnaround times.*

The impact of this event occurring was set to 2, which corresponds to the ranking guideline 'minor energy system disruptions, e.g. short blackouts'. The risk was identified on the basis of personal observations on the island. Any technologies on Rotuma are inflicted with this issue, and even if everything was well planned and spare parts kept in stock on the island, long turn around times inevitably impact on a systems' performance. The probability for this event was set to 4, reflecting the reality of having one boat service per month.

*AB3.2 Damage to plant due to improper use.*

The impact of this event was defined to be a constant 3 for all cases considered. the probability depends on the robustness of the system on one hand and the expertise of operators. The latter can be assumed to be fairly low in a service level 3 concept because there would not be sufficient capital to employ professional operators. Considering the level of problems Rotuman generator operators currently experience with diesel generators, and the relatively higher vulnerability of the more complex wind generator system led to assume a high probability factor, 4.

*CB3.1 Continuous financing problems.*

As specified, this risk factor considers continuous financing problems as a result of high capital and operating costs. The impact of this risk was specified in Section 7.6 as 4. The probability is a function of average household energy costs. At \$53 per household per month, the energy cost is more than double the present Rotuman average. During interviews on the island the author learned that raising the funds for running the generators was a true challenge, and some villages failed here. As defined in Section 7.7.3, the probability of serious financing problems arising is set to 5 if the household energy cost is above \$30 per household

per month.

*CB3.2 Difficulties finding initial lender due to high initial investment.*

It can be very difficult for people on Rotuma to find capital lenders for community projects such as electrification. Most electrification projects in Fiji territories are supported by the Department of Energy. However, the Department of Energy only funds projects that fit into their set programs, and past projects carried out on their behalf on Rotuma were simply mis-designed and faultily installed. The impact of this risk was set to 5 in all cases, because if the the risk was to materialize the project would not go ahead. The probability is a function of the level of initial capital outlay, and critical cost levels are specified in Section 7.7.3. The required capital outlay of \$2.5 million thus corresponds to a probability of 5.

### Resource Security Risks

*RB3.1: Plant repair difficulties due to 50% reduction of access trips to the island due to peak oil* As argued above, it is assumed that peak oil will occur within the 25 year design project life. It is impossible to predict consequences of peak oil on Rotuma. As an optimistic case, it is assumed that peak oil would incur a 50% reduction of boat trips to the island. The impact of this risk was set to 2 and reflects the relatively low dependence on boat trips as compared with diesel generators and also the relatively low impact of energy outages on the functioning of Rotuma at the low service level. The probability for this event is set to 5, reflecting the high likelihood of repair difficulties occurring in the case of further reduction of boat trips to the island.

*RB3.2: Damage of plant due to hurricane strike*

In accordance with Section 7.6, the impact if this event is primarily a function of the hurricane robustness of exposed equipment. Assuming that all turbines are chosen to withstand minor hurricanes, the expected level of damage from a mayor hurricane is expected to be moderate. The probability for this event was determined to be 3 for all cases. This number reflects the probability of a mayor hurricane hitting the island in project life, based on the frequency of past hurricane strikes.

*RB3.3: Wind resource problems due to two months period of missing power winds*

The impact factor of an extended calm period event is a function of the system flexibility and storage capacity. Since storage is one of the most expensive system components, it is hardly possible to plan for unusual wind events by adding storage. Hybrid systems are more flexible because a diesel generator can be run an capacity if no wind is available. The system at hand has limited capacity to cope with calm periods and the likely impact would be temporary system outages. The risk impact factor is therefore evaluated to 3. The probability of this risk has been specified to be 3 in section 7.6. This number is an estimate because there is no long term historic data which would be required for this type of assessment. It is, however, taken into account that personal observations of

some Rotumans (John Bennett, personal communication) showed that periods of intertropical convergence tend to be increasing, which directly translates to extended calm periods.

### **Environmental Risks**

#### *EB3.1: Accumulation of old machinery, excl. batteries*

According to Section 7.6 the impact of this event is evaluated as a function of toxicity of equipment. The technology equipment for small wind turbines is considered unproblematic. Note that batteries are treated separately below. The impact factor is set to 1. The probability is a function of the amount of technology equipment involved. Again, this is comparatively low for the small wind concept and rated as 1.

#### *EB3.2: Soil/groundwater contamination due to battery spillages*

This risk event treats batteries in particular. The impact of this risk is evaluated as 4 across all systems. The probability is seen as a function of the number of batteries required, of the spread of battery installation across the island and the service level. A higher service level would mean professional plant operators and thus a reduced risk of accidental spillages. Overall, the probability of spillages occurring in this system configuration was evaluated as 4.

*EB3.3: Soil/groundwater contamination due to battery dumping* As above, the impact of battery dumping is evaluated as 4 for all systems. The probability of this occurring at a serious level was set to 5, the same considerations as in the previous case applying. From personal observations, battery dumping on Rotuma is a very serious problem. At present, there are only very few lead acid batteries on Rotuma, because of the low number of trucks and cars. Yet, it batteries are seen frequently all around the island. The author saw chickens picking on the corroded lead plates of a decomposing battery. People use batteries for various purposes around places where food is prepared, for example for fencing a cooking fire.

#### *EB3.4: Habitat destruction due to land requirements*

The impact factor for this risk is assumed to be 3 in all cases. The probability is assumed a function of the space requirements of the plant. Space requirements of the present plant are low and the probability is thus given the lowest factor of 1.

#### *EB3.5: Noise pollution due to plant operation*

The impact factor of noise pollution is consistently set to 1 for all concepts, because, while it might be annoying, noise pollution has a relatively low impact on life. The probability is set to 5, because, while small, a small wind turbine is generally installed close to the place of use, i.e. within the village area. Noise would thus, almost certainly impact on a significant portion of the village population.

## 7.9 Risk Results of Concept Independent Risks

This section investigates those risks that depend on the energy service level, but not on any particular energy supply option. In the subsequent sections, these risks are analyzed one energy service level at a time.

### 7.9.1 Level A

#### Feasibility Risks

Ident.	Description	I	P	R
Feasibility issues				
FA.1	Service level opposed by population	5	4	20

### 7.9.2 Level B

#### Feasibility Risks

Ident.	Description	I	P	R
Feasibility issues				
FB.1	Service level with consequences opposed by population	5	2	10
Fundamental issues				
MB.1	High cost of supply of goods due to isolation combined with low population	1	4	4

#### Cultural Dilution

Ident.	Description	I	P	R
UB.1	Reduction/gradual loss of redistribution custom	4	2	8
UB.2	Reduction/gradual loss of mutual reciprocity of services	5	2	10
UB.3	Reduction/gradual loss of functionality of traditional leadership	4	3	12
UB.4	Reduction/gradual loss of planting and gardening skills	5	1	5

#### Environmental Problem Risks

Ident.	Description	I	P	R
EB.1	Soil/groundwater contamination through accumulation of old appliance rubbish	3	3	9

### 7.9.3 Level C

#### Feasibility Risks

Ident.	Description	I	P	R
Feasibility issues				
FB.1	Service level with consequences opposed by population	5	3	15
Fundamental issues				
MB.1	High cost of supply of goods due to isolation combined with low population	2	4	8

#### Cultural Dilution

Ident.	Description	I	P	R
UB.1	Reduction/gradual loss of redistribution custom	4	3	12
UB.2	Reduction/gradual loss of mutual reciprocity of services	5	4	20
UB.3	Reduction/gradual loss of functionality of traditional leadership	4	4	16
UB.4	Reduction/gradual loss of planting and gardening skills	5	2	10

#### Environmental Problem Risks

Environmental risks:

Ident.	Description	I	P	R
EB.1	Soil/groundwater contamination through accumulation of old appliance rubbish	4	4	16

### 7.9.4 Level D

#### Feasibility Risks

Ident.	Description	I	P	R
Feasibility issues				
FB.1	Service level with consequences opposed by population	5	5	25
Fundamental issues				
MB.1	High cost of supply of goods due to isolation combined with low population	4	4	16

**Cultural Dilution**

Ident.	Description	I	P	R
UB.1	Reduction/gradual loss of redistribution custom	4	5	20
UB.2	Reduction/gradual loss of mutual reciprocity of services	5	5	25
UB.3	Reduction/gradual loss of functionality of traditional leadership	4	5	20
UB.4	Reduction/gradual loss of planting and gardening skills	5	4	20

**Environmental Problem Risks**

Ident.	Description	I	P	R
EB.1	Soil/groundwater contamination through accumulation of old appliance rubbish	5	4	20

## 7.10 Modelling and Risk Results of B-Level Systems

As explained previously, the level B model is based on an average sized village (27 households). The modelled data are then multiplied by the number of existing mini-grids (18) to obtain total figures for Rotuma.

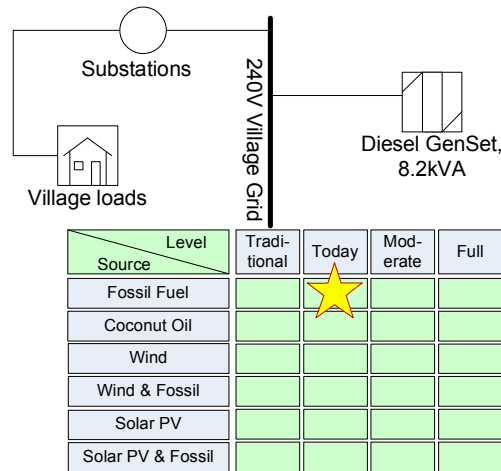

Figure 7.7: Diesel Generation Scheme

Table 7.22: Modelling results - Level B - Diesel

Initial Capital <sup>a</sup>	Total NPV <sup>ab</sup>	COE <sup>c</sup>	DEC <sup>d</sup>	Diesel
F\$136,782	F\$1,037,538	0.94F\$/kWh	12.53F\$/month	35,910l/a

<sup>a</sup>Value for the sum of 18 village systems

<sup>b</sup>NPV stands for Net Present Value.

<sup>c</sup>COE stands for Cost of Energy and refers to the levelized electricity cost per kWh.

<sup>d</sup>DEC stands for Domestic Energy Cost, and refers to the levelized electricity cost per household per month.

### 7.10.1 Fossil Fuel Supply

The reference energy system for this option is simply an “improved” version of the present system. Design flaws in the present system are corrected. All three-phase village generators are replaced by two-phase units. Over-capacity generators are replaced with appropriately sized units. The system configuration is shown in Figure 7.7. An 8.2kVA generator is suitable for the average village on Rotuma. System cost, summarized in Table 7.22, include costs for immediate replacement of all existing generators with appropriately sized units. Even though the monthly domestic energy costs include all system capital costs, domestic energy costs are none-the-less on the lower end of the scale of present day energy bills (Note that at present, energy bills include only fuel costs while capital was raised through fundraising activity). This is possible because of fuel savings due to an appropriately sized generator. The diesel fuel consumption for the whole island is 36,910 l per year.



**Feasibility Risks**

Ident.	Description	I	P	R
Application issues				
AB1.1	Repair delays due to long turnaround times	2	4	8
AB1.2	Damage to plant due to improper use	3	2	6
Cost issues				
CB1.1	Continuous financing problems	4	2	8
CB1.2	Difficulties finding initial lender due to high initial investment	5	2	10

**Resource Security Risks**

Ident.	Description	I	P	R
RB1.1	System disruptions by 50% petroleum reduction of petroleum product imports	4	5	20
RB1.2	Plant repair difficulties due to 50% reduction of access trips to the island due to peak oil	2	5	10
RB1.3	Damage of plant due to hurricane strike	1	3	3

**Environmental Problem Risks**

Ident.	Description	I	P	R
EB1.1	Accumulation of old machinery, excl. batteries	1	1	1
EB1.2	Large scale contamination of soil/groundwater by waste engine oil	3	1	3
EB1.3	Soil/groundwater contamination due to petroleum fuel spills on land	4	2	8
EB1.4	Sea contamination due to petroleum fuel spills during delivery	4	1	4
EB1.5	Local air pollution due to engine exhausts	2	2	4
EB1.6	Noise pollution due to plant operation	1	5	5

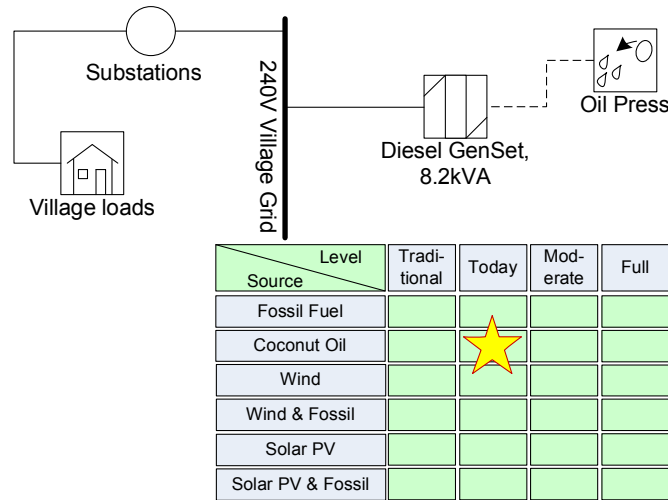

Figure 7.8: Level B: Coconut Generation Scheme

Table 7.23: Modelling results - Level B - Coconut oil

Initial Capital <sup>a</sup>	Total NPV <sup>b</sup>	COE <sup>c</sup>	DEC <sup>d</sup>	Diesel
F\$206,280	F\$886,254	0.78F\$/kWh	10.41F\$/month	39,474l/a

<sup>a</sup>All values are for the sum of 18 village systems

<sup>b</sup>NPV stands for Net Present Value.

<sup>c</sup>COE stands for Cost of Energy and refers to the levelized electricity cost per kWh.

<sup>d</sup>DEC stands for Domestic Energy Cost, and refers to the levelized electricity cost per household per month.

## 7.10.2 Coconut Oil Supply

In this system, coconut oil is produced on the island from local copra resources. In this case, the diesel generators are of the same size as in the diesel generation case, but modified for the use of coconut oil. Modifications accommodate for preheating the fuel. Cost parameters for this option, shown in Figure 7.23, include investments for a small copra processing plant under 'initial capital'. The copra resource required is 66t of dried copra per year, or roughly 30% of the present production. In the case of intensive cultivation, this amount of copra could be produced from a land area of 13ha, i.e. 0.3% of Rotuma's land area.

Annual dried copra requirements for producing  $39 \times 10^3$ l of coconut oil are 66t.

**Feasibility Risks**

Ident.	Description	I	P	R
Fundamental issues				
MB2.1	Engine problems due to coconut oil caused corrosion	3	4	12
Technical issues				
TB2.1	Failure of coconut oil conversion equipment due to non-standardization of equipment	4	3	12
Application issues				
AB2.1	Repair delays due to long turnaround times	3	4	12
AB2.2	Damage to plant due to improper use	3	4	12
Cost issues				
CB2.1	Continuous financing problems	4	2	8
CB2.2	Difficulties finding initial lender due to high initial investment	5	2	10

**Resource Security Risks**

Ident.	Description	I	P	R
RB2.1	System disruptions by 50% petroleum reduction of petroleum product imports	4	5	20
RB2.2	Plant repair difficulties due to 50% reduction of access trips to the island due to peak oil	2	4	8
RB2.3	Damage of plant due to hurricane strike	0	3	0

**Environmental Problem Risks**

Ident.	Description	I	P	R
EB2.1	Accumulation of old machinery, excl. batteries	1	2	2
EB2.2	Large scale contamination of soil/groundwater by waste engine oil	3	1	3
EB2.3	Soil/groundwater contamination due to petroleum fuel spills on land	3	1	3
EB2.4	Sea contamination due to petroleum fuel spills during delivery	3	1	3
EB2.5	Local air pollution due to engine exhausts	1	1	1
EB2.6	Noise pollution due to plant operation	1	1	1

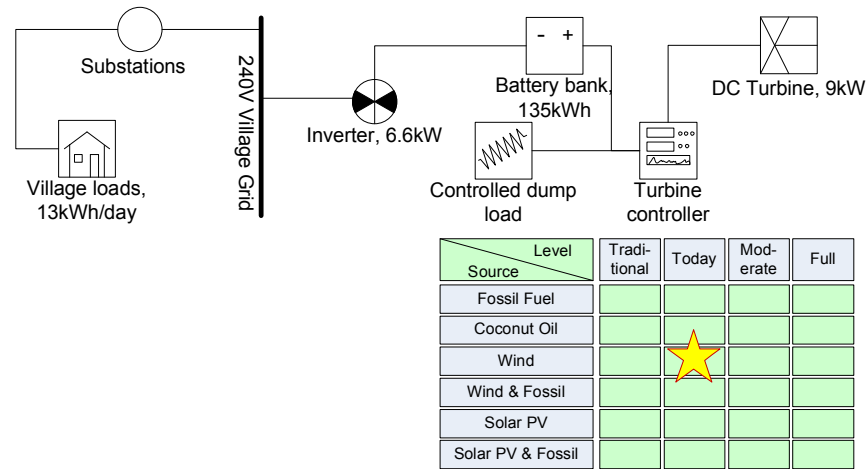

Figure 7.9: Level B: Wind generation scheme.

### 7.10.3 Wind Supply

The third energy supply option for a level B service level are separate wind energy systems for each village grid. Energy storage is by means of battery banks. Available wind power varies from village to village. For the sake of modelling, the windiest spots within 300m radii from the respective village areas were selected. Wind speeds at these 18 different village sites were determined from the wind map (25m) and the mean of these used as modelling input. The mean wind speed at 25m anemometer height is 5.15m/s with a standard deviation of 0.63 from village to village. The range is from 3.8m/s to 6m/s with a median wind speed of 5.2m/s. Using the mean wind speed for modelling all places is a simplifying assumption but seems appropriate for an initial feasibility. In reality, the six villages with wind speeds below 5m/s would need larger turbines if they were to go ahead with wind power. However, this would not significantly change the cost situation for the whole island. HOMER was used to optimize the ratio of energy storage vs. wind power at the technology costs given in Section 7.5. As shown in Figure 7.9, the optimized village system is based on one 9kW wind generator, and a 135kWh battery bank, i.e. 100 single deep cycle batteries (3.4t per village or 61t island wide). System costs for the whole system (18 village systems) are shown in Table 7.24.

Table 7.24: Modelling results - Level B - Wind

Initial Capital <sup>a</sup>	Total NPV <sup>ab</sup>	COE <sup>c</sup>	DEC <sup>d</sup>
F\$2,480,832	F\$4,352,832	3.96F\$/kWh	52.55F\$/month

<sup>a</sup>Value for the sum of 18 village systems

<sup>b</sup>NPV stands for Net Present Value.

<sup>c</sup>COE stands for Cost of Energy and refers to the levelized electricity cost per kWh.

<sup>d</sup>DEC stands for Domestic Energy Cost, and refers to the levelized electricity cost per household per month.

### Feasibility Risks

Ident.	Description	I	P	R
Fundamental issues				
MB3.1	Premature turbine failure due to corrosion in marine environment	3	2	6
Application issues				
AB3.1	Repair delays due to long turnaround times	2	4	8
AB3.2	Damage to plant due to improper use	3	3	9
Cost issues				
CB3.1	Continuous financing problems	4	5	20
CB3.2	Difficulties finding initial lender due to high initial investment	5	5	25

### Resource Security Risks

Ident.	Description	I	P	R
RB3.1	Plant repair difficulties due to 50% reduction of access trips to the island due to peak oil	2	5	10
RB3.2	Damage of plant due to hurricane strike	3	3	9
RB3.3	Wind resource problems due to two months period of missing power winds	3	3	9

### Environmental Risks

Ident.	Description	I	P	R
EB3.1	Accumulation of old machinery, excl. batteries	1	1	1
EB3.2	Soil/groundwater contamination due to battery spillages	4	4	16
EB3.3	Soil/groundwater contamination due to battery dumping	5	4	20
EB3.4	Habitat destruction due to land requirements	3	1	3
EB3.5	Noise pollution due to plant operation	1	5	5

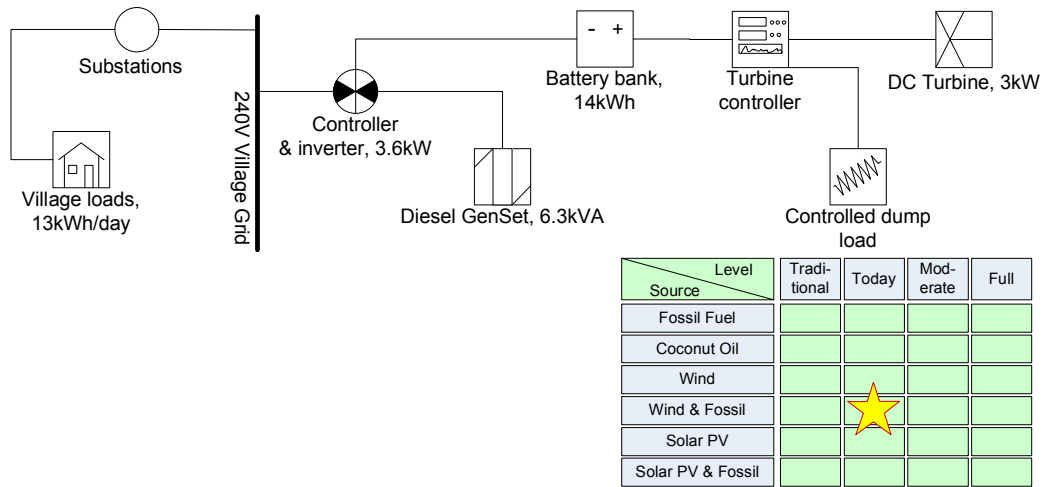

Figure 7.10: Level B: Wind diesel hybrid generation scheme.

Table 7.25: Modelling results - Level B - Wind Diesel.

Initial Capital <sup>a</sup>	Total NPV <sup>a,b</sup>	COE <sup>c</sup>	DEC <sup>d</sup>	Diesel
F\$850,050	F\$1.964,286	1.79F\$/kWh	23.71F\$/month	23,256l/a

<sup>a</sup>Value for the sum of 18 village systems

<sup>b</sup>NPV stands for Net Present Value.

<sup>c</sup>COE stands for Cost of Energy and refers to the levelized electricity cost per kWh.

<sup>d</sup>DEC stands for Domestic Energy Cost, and refers to the levelized electricity cost per household per month.

### 7.10.4 Wind-Diesel Hybrid supply

As a variation of the pure wind power supply system, the wind-diesel hybrid system reduces the need for energy storage. Precondition for this system was a minimum renewability factor of 50% (see Figure 7.10). A small number of batteries (14kWh, or 6.3t island wide) had to be added for short term energy storage (approx. one day) and to mitigate fluctuations due to high wind penetration as well as storing incoming wind energy throughout the day for use during the four hours of demand. System costs are shown in Table 7.31. Diesel savings compared to the diesel-only system are 35%.

**Feasibility Risks**

Ident.	Description	I	P	R
Fundamental issues				
MB4.1	Premature turbine failure due to corrosion in marine environment	3	2	6
Application issues				
AB4.1	Repair delays due to long turnaround times	2	4	8
AB4.2	Damage to plant due to improper use	3	4	12
Cost issues				
CB4.1	Continuous financing problems	4	4	16
CB4.2	Difficulties finding initial lender due to high initial investment	5	4	20

**Resource Security Risks**

Ident.	Description	I	P	R
RB4.1	System disruptions by 50% petroleum reduction of petroleum product imports	3	5	15
RB4.2	Plant repair difficulties due to 50% reduction of access trips to the island due to peak oil	2	5	10
RB4.3	Damage of plant due to hurricane strike	3	3	9
RB4.4	Wind resource problems due to two months period of missing power winds	2	3	6

**Environmental Problem Risks**

Ident.	Description	I	P	R
EB4.1	Accumulation of old machinery, excl. batteries	1	2	2
EB4.2	Large scale contamination of soil/groundwater by waste engine oil	3	1	3
EB4.3	Soil/groundwater contamination due to petroleum fuel spills on land	4	1	4
EB4.4	Sea contamination due to petroleum fuel spills during delivery	4	1	4
EB4.5	Soil/groundwater contamination due to battery spillages	4	3	12
EB4.6	Soil/groundwater contamination due to battery dumping	5	3	15
EB4.7	Habitat destruction due to land requirements	3	1	3
EB4.8	Local air pollution due to engine exhausts	1	2	2
EB4.9	Noise pollution due to plant operation	1	5	5

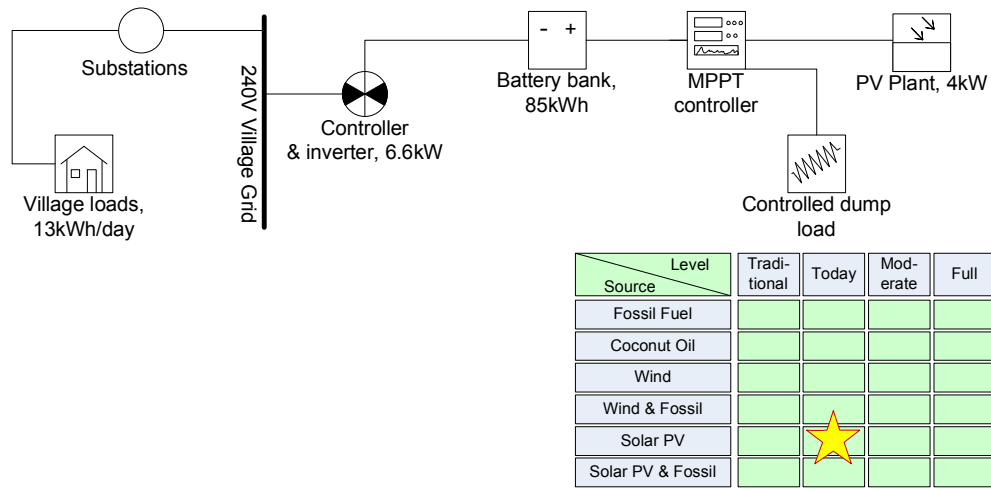

Figure 7.11: Level B: Solar PV generation scheme.

Table 7.26: Modelling results - Level B - Solar PV

Initial Capital <sup>a</sup>	Total NPV <sup>ab</sup>	COE <sup>c</sup>	DEC <sup>d</sup>
F\$1,969,452	F\$3,622,248	3.29F\$/kWh	43.73F\$/month

<sup>a</sup>Value for the sum of 18 village systems

<sup>b</sup>NPV stands for Net Present Value.

<sup>c</sup>COE stands for Cost of Energy and refers to the levelized electricity cost per kWh.

<sup>d</sup>DEC stands for Domestic Energy Cost, and refers to the levelized electricity cost per household per month.

### 7.10.5 Solar PV supply

The solar PV supply system (in Figure 7.11) involved energy storage in battery banks. The size of the solar PV panels per village covers roughly  $56m^2$  of land area. The 85kWh battery bank without cabling amounts to 1.8t of battery weight per village (34t island wide).



**Feasibility Risks**

Ident.	Description	I	P	R
Fundamental issues				
MB5.1	Premature PV panel failure due to corrosive marine environment	3	2	6
Application issues				
AB5.1	Repair delays due to long turnaround times	4	4	16
AB5.2	Damage to plant due to improper use	3	3	9
Cost issues				
CB5.1	Continuous financing problems	4	5	20
CB5.2	Difficulties finding initial lender due to high initial investment	5	5	25

**Resource Security Risks**

Ident.	Description	I	P	R
RB5.1	Plant repair difficulties due to 50% reduction of access trips to the island due to peak oil	4	5	20
RB5.2	Damage of plant due to hurricane strike	4	3	12
RB5.3	Solar resource problems due to three weeks period of no sun	4	3	12

**Environmental Problem Risks**

Ident.	Description	I	P	R
EB5.1	Accumulation of old machinery, excl. batteries	2	3	6
EB5.2	Soil/groundwater contamination due to battery spillages	4	4	16
EB5.3	Soil/groundwater contamination due to battery dumping	5	4	20
EB5.4	Habitat destruction due to land requirements	3	1	3

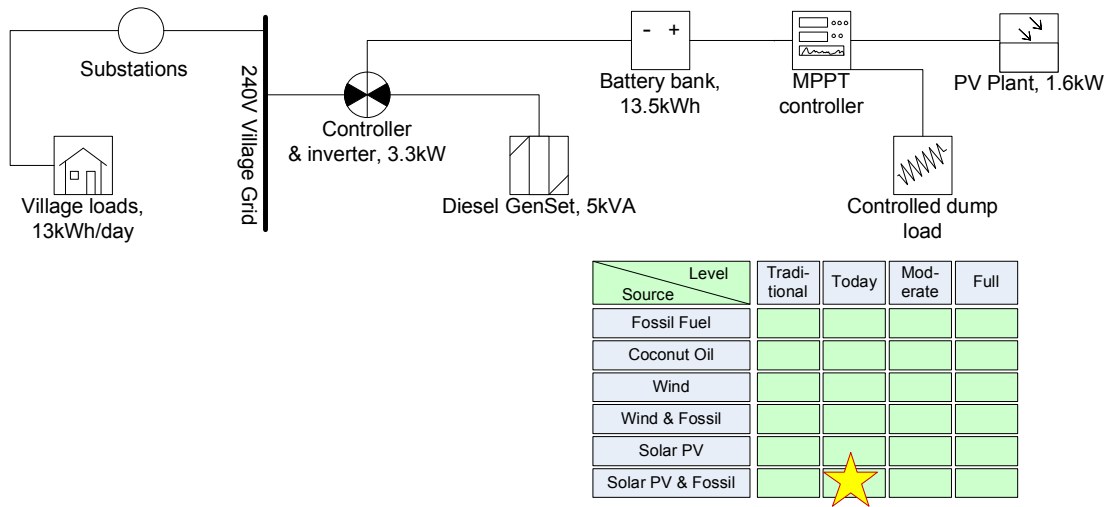

Figure 7.12: Level B: Solar PV Diesel Hybrid generation scheme.

Table 7.27: Modelling results - Level B - Solar PV–Diesel hybrid system.

Initial Capital <sup>a</sup>	Total NPV <sup>ab</sup>	COE <sup>c</sup>	DEC <sup>d</sup>	Diesel
F\$838,134	F\$2,114,784	1.92F\$/kWh	25.53F\$/month	20,124/a

<sup>a</sup>Value for the sum of 18 village systems

<sup>b</sup>NPV stands for Net Present Value.

<sup>c</sup>COE stands for Cost of Energy and refers to the levelized electricity cost per kWh.

<sup>d</sup>DEC stands for Domestic Energy Cost, and refers to the levelized electricity cost per household per month.

### 7.10.6 Solar PV-Diesel Hybrid supply

This scheme uses a PV plant combined with diesel generation (see Figure 7.12). The PV plant is reduced to a rated capacity of 1.6kW or 23m<sup>2</sup> of solar panel area per village. A 5kVA diesel generator supplies power during periods of insufficient sunshine. Some battery storage is still required in this concept because times of energy demand and solar energy supply do not overlap. The battery bank was sized as small as possible but able to store at least one day’s worth of solar energy at less than 50% depth of discharge on the battery side. Compared to the pure diesel based system, the solar hybrid system reduces the diesel demand by 44%.

**Feasibility Risks**

Ident.	Description	I	P	R
Fundamental issues				
MB6.1	Premature PV panel failure due to corrosive marine environment	3	2	6
Application issues				
AB6.1	Repair delays due to long turnaround times	3	4	12
AB6.2	Damage to plant due to improper use	3	3	9
Cost issues				
CB6.1	Continuous financing problems	4	4	16
CB6.2	Difficulties finding initial lender due to high initial investment	5	4	20

**Resource Security Risks**

Ident.	Description	I	P	R
RB56.1	System disruptions by 50% petroleum reduction of petroleum product imports	3	5	15
RB6.2	Plant repair difficulties due to 50% reduction of access trips to the island due to peak oil	3	5	15
RB6.3	Damage of plant due to hurricane strike	2	3	6
RB6.4	Solar resource problems due to three weeks period of no sun	2	3	6

**Environmental Problem Risks**

Environmental risks:

Ident.	Description	I	P	R
EB6.1	Accumulation of old machinery, excl. batteries	1	2	2
EB6.2	Large scale contamination of soil/groundwater by waste engine oil	3	1	3
EB6.3	Soil/groundwater contamination due to petroleum fuel spills on land	4	1	4
EB6.4	Sea contamination due to petroleum fuel spills during delivery	4	1	4
EB6.5	Soil/groundwater contamination due to battery spillages	4	3	12
EB6.6	Soil/groundwater contamination due to battery dumping	5	3	15
EB6.7	Habitat destruction due to land requirements	3	1	3
EB6.8	Local air pollution due to engine exhausts	1	2	2
EB6.9	Noise pollution due to plant operation	1	5	5

## **7.11 Modelling and Risk Results of C–Level Systems**

All energy models for energy service level C are based on a central energy system and an island-wide grid. The grid is an 11kVA grid which feeds into the existing village level grids at the existing substations. Costs of the grid are included in the initial investment and operation and maintenance costs of the overall systems. The ideal location of the power plant varies from option to option.

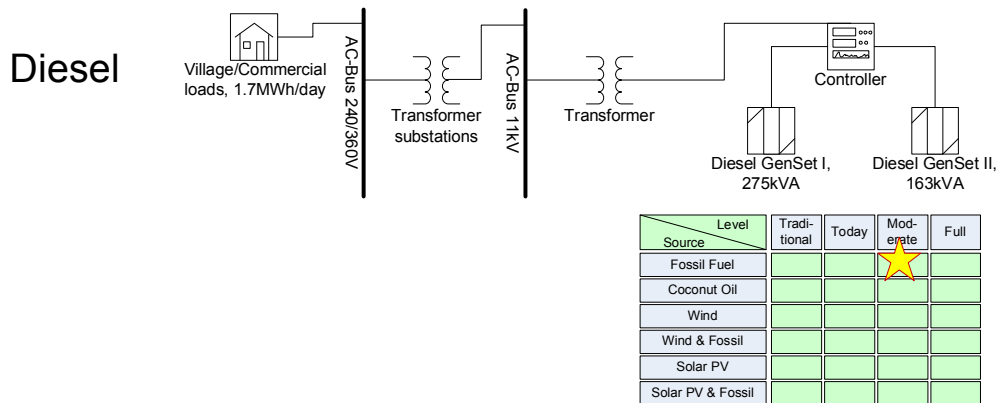

Figure 7.13: Level C: Diesel Generation Scheme.

Table 7.28: Modelling results - Level C - Diesel

Initial Capital	Total NPV <sup>a</sup>	COE <sup>b</sup>	DEC <sup>c</sup>	Diesel
F\$2,068,694	F\$8,376,832	1.06F\$/kWh	91.83F\$/month	226×10 <sup>3</sup> l/a

<sup>a</sup>NPV stands for Net Present Value.

<sup>b</sup>COE stands for Cost of Energy and refers to the levelized electricity cost per kWh.

<sup>c</sup>DEC stands for Domestic Energy Cost, and refers to the levelized electricity cost per household per month.

### 7.11.1 Fossil Fuel Supply

The first power supply option for energy service level C is a standard diesel generation system. The system configuration is shown in Figure 7.13. The power is supplied by two synchronized diesel generators. The optimum configuration was found to be with one generator of 275kVA and one with 163kVA. System costs are shown in Table 7.28.

### Feasibility Risks

Ident.	Description	I	P	R
Application issues				
AC1.1	Repair delays due to long turnaround times	2	3	6
AC1.2	Damage to plant due to improper use	3	1	3
Cost issues				
CC1.1	Continuous financing problems	4	4	16
CC1.2	Difficulties finding initial lender due to high initial investment	5	3	15

**Resource Security Risks**

Ident.	Description	I	P	R
RC1.1	System disruptions by 50% petroleum reduction of petroleum product imports	4	5	20
RC1.2	Plant repair difficulties due to 50% reduction of access trips to the island due to peak oil	2	4	8
RC1.3	Damage of plant due to hurricane strike	1	3	3

**Environmental Problem Risks**

Environmental risks:

Ident.	Description	I	P	R
EC1.1	Accumulation of old machinery, excl. batteries	1	2	2
EC1.2	Large scale contamination of soil/groundwater by waste engine oil	3	1	3
EC1.3	Soil/groundwater contamination due to petroleum fuel spills on land	4	1	4
EC1.4	Sea contamination due to petroleum fuel spills during delivery	4	2	8
EC1.5	Local air pollution due to engine exhausts	1	1	1
EC1.6	Noise pollution due to plant operation	1	1	1

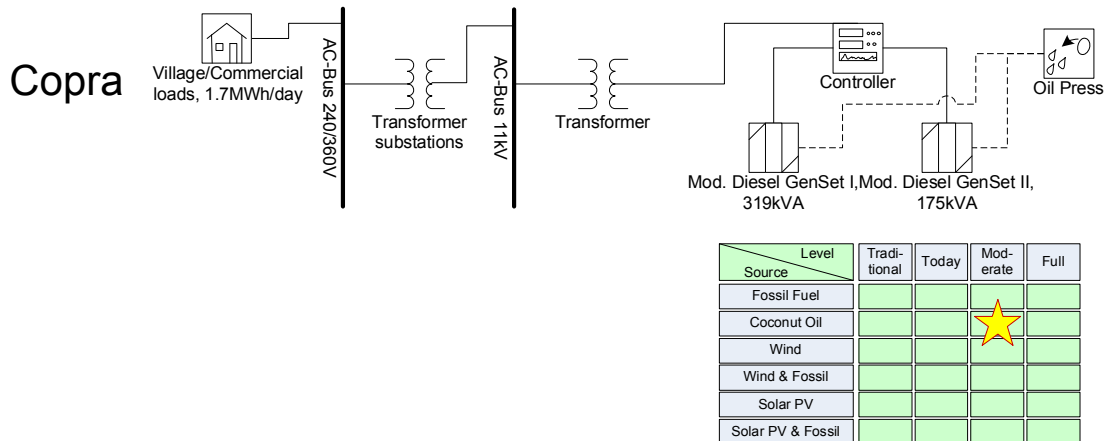

Figure 7.14: Level C: Coconut Generation Scheme

Table 7.29: Modelling results - Level C - Coconut oil

Initial Capital	Total NPV <sup>a</sup>	COE <sup>b</sup>	DEC <sup>c</sup>	Coconut oil
F\$2,452,382	F\$7,051,504	0.89F\$/kWh	77.30F\$/month	234×10 <sup>3</sup> l/a

<sup>a</sup>NPV stands for Net Present Value.

<sup>b</sup>COE stands for Cost of Energy and refers to the levelized electricity cost per kWh.

<sup>c</sup>DEC stands for Domestic Energy Cost, and refers to the levelized electricity cost per household per month.

### 7.11.2 Coconut Oil Supply

With modified diesel generators, the system described in the previous section is fuelled by coconut oil. The coconut oil power system concept is shown in Figure 7.14. Due to different generator and fuel costs as well as slightly different generator performance when run with coconut oil, the optimum generator capacities are slightly shifted when compared with the conventional diesel system. System costs including all coconut oil production costs are summarized in Table 7.29. Dried copra requirements for this concept are at least 390t per year. As shown in Chapter 6, this production could be easily covered with existing trees. However, the present copra production would have to double. For reference, in intensive cultivation this amount of copra could be produced from a land area of 98ha or 2% of Rotuma's land area.

**Feasibility Risks**

Ident.	Description	I	P	R
Fundamental issues				
MC2.1	Engine problems due to coconut oil caused corrosion	3	3	9
Technical issues				
TC2.1	Failure of coconut oil conversion equipment due to non-standardization of equipment	3	3	9
Application issues				
ABC2.1	Repair delays due to long turnaround times	3	3	9
AC2.2	Damage to plant due to improper use	3	2	6
Cost issues				
CC2.1	Continuous financing problems	4	3	12
CC2.2	Difficulties finding initial lender due to high initial investment	5	3	15

**Resource Security Risks**

Ident.	Description	I	P	R
RC2.1	Plant repair difficulties due to 50% reduction of access trips to the island due to peak oil	3	4	12
RC2.2	Local supply problems due to dramatic rise in world coconut oil price	4	2	8
RC2.3	Supply shortage due to hurricane strike	2	3	6

**Environmental Problem Risks**

Environmental risks:				
Ident.	Description	I	P	R
EC2.1	Accumulation of old machinery, excl. batteries	1	2	2
EC2.2	Large scale contamination of soil/groundwater by waste engine oil	3	1	3
EC2.3	Habitat destruction due to land requirements	3	1	3
EC2.4	Local air pollution due to engine exhausts	1	1	1
EC2.5	Noise pollution due to plant operation	1	1	1



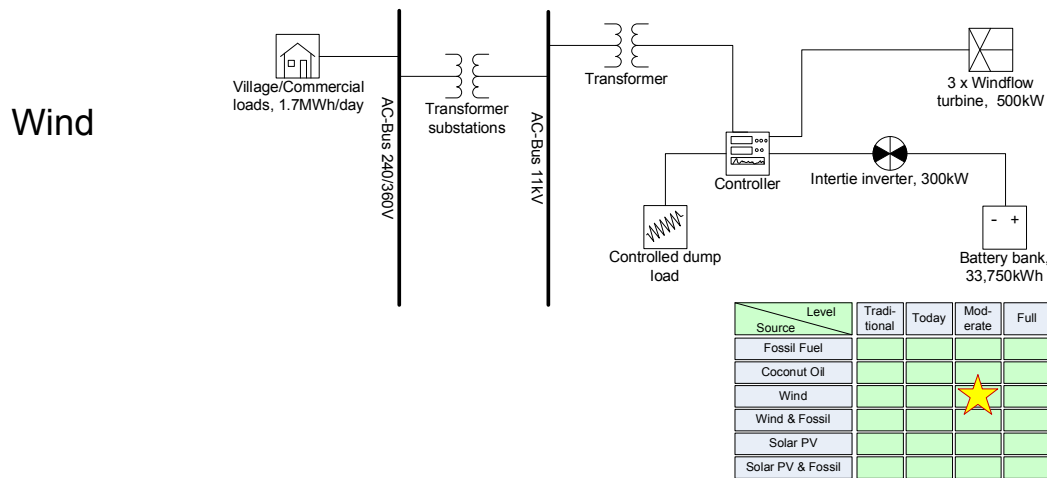

Figure 7.15: Level C: Wind generation scheme.

Table 7.30: Modelling results - Level C - Wind

Initial Capital	Total NPV <sup>a</sup>	COE <sup>b</sup>	DEC <sup>c</sup>
F\$17,158,112	F\$28,108,476	3.56F\$/kWh	308.13F\$/month

<sup>a</sup>NPV stands for Net Present Value.

<sup>b</sup>COE stands for Cost of Energy and refers to the levelized electricity cost per kWh.

<sup>c</sup>DEC stands for Domestic Energy Cost, and refers to the levelized electricity cost per household per month.

### 7.11.3 Wind Power

The wind supply option for level C (see Figure 7.15) uses three Windflow 500 turbines, and a battery bank provides energy storage. Pumped storage was considered but discarded because of high costs<sup>2</sup>. At a battery weight of 844t, the proposed 33,750kWh battery bank is large and would require a separate building.

#### Feasibility Risk

At a domestic energy cost of F\$308 per month the concept is not financially feasible. The high cost is largely due to expensive energy storage; the battery bank alone makes up 59% of the total annualized costs, with 28% of annualized costs attributable to the wind turbines.

<sup>2</sup>A pumped storage system was modelled in Section 7.12.3. Estimated costs for such a system are very high and a smaller system would be expected to have higher relative costs.

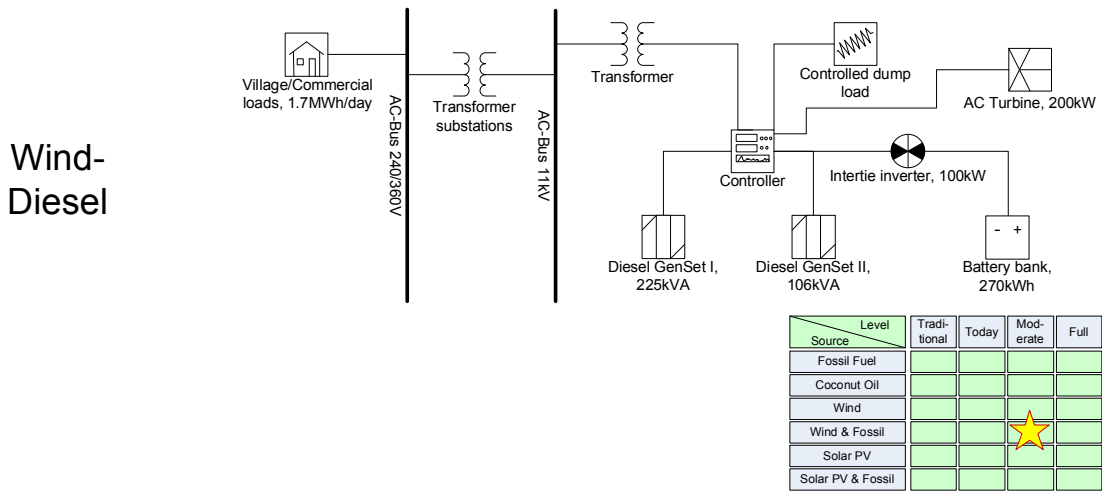

Figure 7.16: Level C: Wind diesel hybrid generation scheme.

Table 7.31: Modelling results - Level C - Wind Diesel

Initial Capital	Total NPV <sup>a</sup>	COE <sup>b</sup>	DEC <sup>c</sup>	Diesel
F\$3,072,036	F\$593,137	0.96F\$/kWh	83.12F\$/month	136 × 10 <sup>3</sup> l/a

<sup>a</sup>NPV stands for Net Present Value.

<sup>b</sup>COE stands for Cost of Energy and refers to the levelized electricity cost per kWh.

<sup>c</sup>DEC stands for Domestic Energy Cost, and refers to the levelized electricity cost per household per month.

### 7.11.4 Wind Diesel Hybrid System

High energy storage costs are mitigated by using the hybrid wind diesel system. This concept uses a 200kW wind turbine, i.e. 87% less wind capacity while still satisfying the 50% wind penetration requirement. This is mainly because in the pure wind concept it is cheaper to install a vast wind overcapacity than adding more very expensive storage. This concept incurs 40% of diesel savings compared with the pure diesel concept.

**Feasibility Risks**

Ident.	Description	I	P	R
Fundamental issues				
MC4.1	Premature turbine failure due to corrosion in marine environment	3	1	3
Application issues				
TC4.1	Power quality problems due to high wind penetration	1	4	4
Application issues				
AC4.1	Repair delays due to long turnaround times	2	3	6
AC4.2	Damage to plant due to improper use	3	2	6
Cost issues				
CC4.1	Continuous financing problems	4	4	16
CC4.2	Difficulties finding initial lender due to high initial investment	5	3	15

**Resource Security Risks**

Ident.	Description	I	P	R
RC4.1	System disruptions by 50% petroleum reduction of petroleum product imports	3	5	15
RC4.2	Plant repair difficulties due to 50% reduction of access trips to the island due to peak oil	2	4	8
RC4.3	Damage of plant due to hurricane strike	3	3	9
RC4.4	Wind resource problems due to two months period of missing power winds	2	3	6

**Environmental Problem Risks**

Ident.	Description	I	P	R
EC4.1	Accumulation of old machinery, excl. batteries	1	3	3
EC4.2	Large scale contamination of soil/groundwater by waste engine oil	3	1	3
EC4.3	Soil/groundwater contamination due to petroleum fuel spills on land	4	1	4
EC4.4	Sea contamination due to petroleum fuel spills during delivery	4	1	4
EC4.5	Soil/groundwater contamination due to battery spillages	4	3	12
EC4.6	Soil/groundwater contamination due to battery dumping	5	3	15
EC4.7	Decimation of bird populations due to large wind turbines	2	2	4
EC4.8	Habitat destruction due to land requirements	3	1	3
EC4.9	Local air pollution due to engine exhausts	1	1	1
EC4.10	Noise pollution due to plant operation	1	3	3

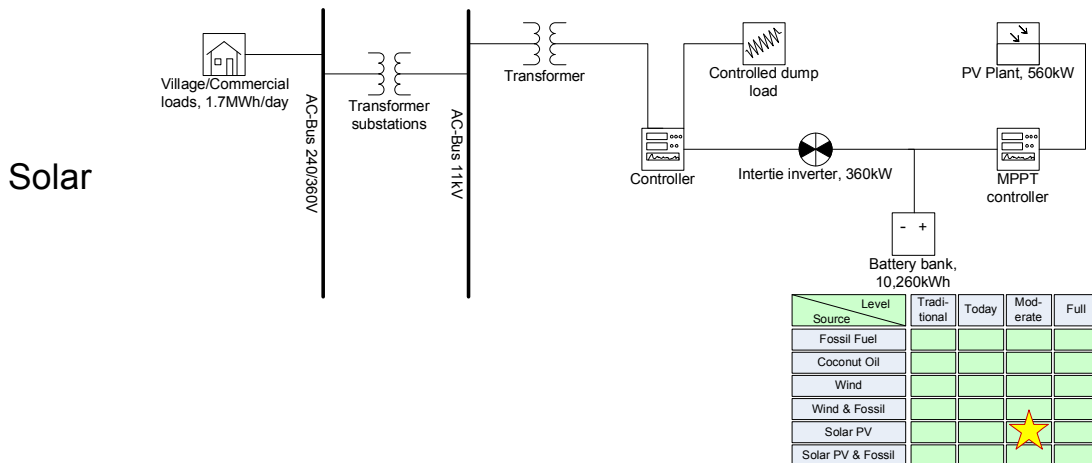

Figure 7.17: Level C: Solar PV generation scheme.

Table 7.32: Modelling results - Level C - Solar PV

Initial Capital	Total NPV <sup>a</sup>	COE <sup>b</sup>	DEC <sup>c</sup>
F\$13,495,278	F\$22,077,796	2.80F\$/kWh	242.02F\$/month

<sup>a</sup>NPV stands for Net Present Value.

<sup>b</sup>COE stands for Cost of Energy and refers to the levelized electricity cost per kWh.

<sup>c</sup>DEC stands for Domestic Energy Cost, and refers to the levelized electricity cost per household per month.

### 7.11.5 Solar PV

This concept uses a 560kW solar PV plant with battery storage (see Figure 7.17). The plant requires a PV panel array of  $7350m^2$ , roughly the area of a soccer field. The battery bank has a capacity of 10,260kWh amounting to roughly 257t. Costs are presented in Table 7.32.

#### Feasibility Risk

High domestic energy costs render this concept financially unfeasible. Of domestic energy costs, 61% are vested in the PV panel array with 23% of costs sunk into the battery storage system.

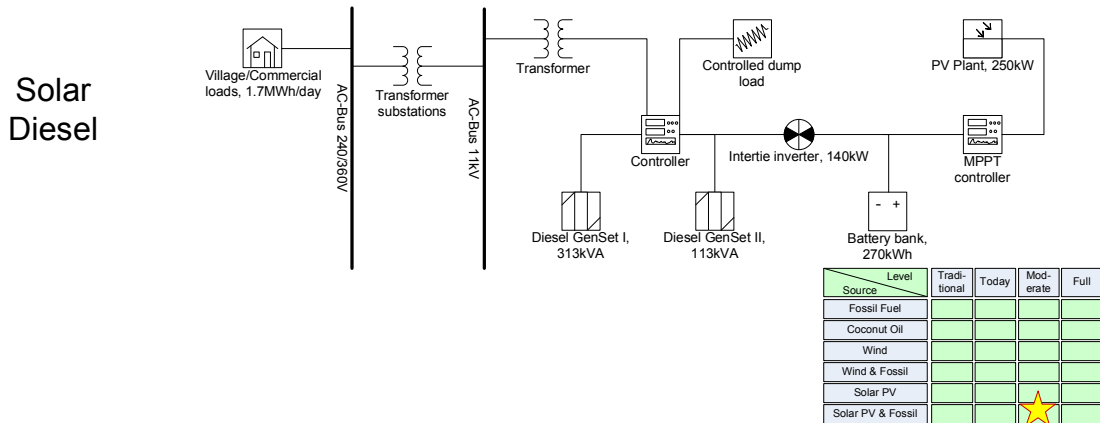

Figure 7.18: Level C: Solar PV Diesel Hybrid generation scheme.

Table 7.33: Modelling results - Level C - Solar PV Diesel.

Initial Capital	Total NPV <sup>a</sup>	COE <sup>b</sup>	DEC <sup>c</sup>	Diesel
F\$6,016,389	F\$12.759,934	1.62F\$/kWh	139.88F\$/month	135 × 10 <sup>3</sup> l/a

<sup>a</sup>NPV stands for Net Present Value.

<sup>b</sup>COE stands for Cost of Energy and refers to the levelized electricity cost per kWh.

<sup>c</sup>DEC stands for Domestic Energy Cost, and refers to the levelized electricity cost per household per month.

### 7.11.6 Solar PV-Diesel Hybrid System

The hybrid version of the level C solar system (see Figure 7.18 requires a 250kW (3,525m<sup>2</sup>) PV array. Short term battery storage of 270kWh (7t) greatly reduces generator run time. Two generators of 313kVA and 113kVA provide power during low sunshine periods. Diesel fuel savings compared to the diesel-only variant amount to 40%.

### Feasibility Risk

High domestic energy costs make this option financially unfeasible. Of the domestic energy costs, 47% are for the PV panel array, 30% for both generators including the diesel fuel, and 20% for other components including grid, batteries and converters.

## **7.12 Modelling and Risk Results of D-Level Systems**

As for level C systems, level D system concepts are based on an island wide electricity grid. All six supply concepts are discussed in the subsequent sections.

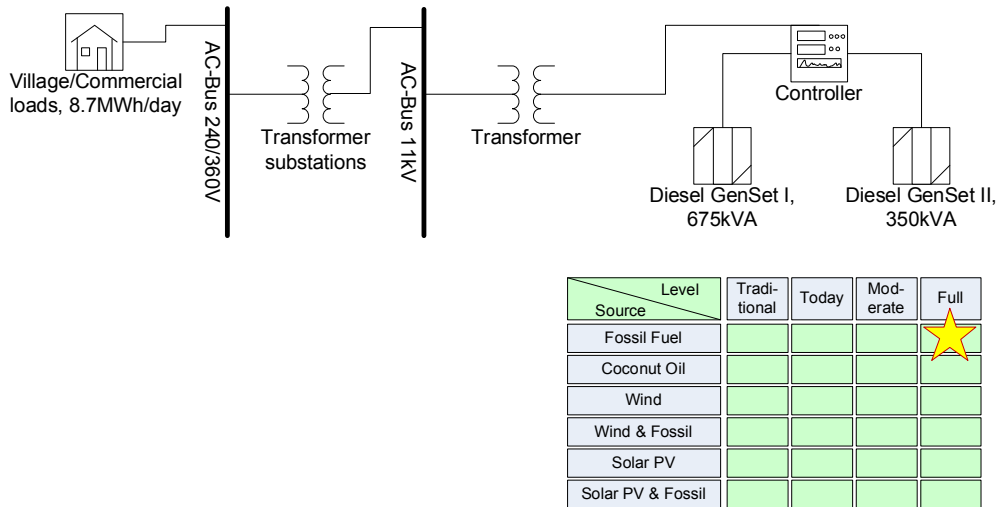

Figure 7.19: Level D: Diesel Generation Scheme.

Table 7.34: Modelling results - Level D - Diesel.

Initial Capital	Total NPV <sup>a</sup>	COE <sup>b</sup>	DEC <sup>c</sup>	Diesel
F\$2,222,222	F\$32,435,054	0.80F\$/kWh	196.80F\$/month	1160 × 10 <sup>3</sup> l/a

<sup>a</sup>NPV stands for Net Present Value.

<sup>b</sup>COE stands for Cost of Energy and refers to the levelized electricity cost per kWh.

<sup>c</sup>DEC stands for Domestic Energy Cost, and refers to the levelized electricity cost per household per month.

### 7.12.1 Fossil Fuel Supply

The fossil fuel option for level D is based on two generator sets of 675kVA and 350kVA. The annual diesel consumption is 1.2m *l/year*.

#### Feasibility Risk

At the present cost of diesel fuel on Rotuma, this option is not financially feasible. Diesel fuel alone accounts for 85% of the domestic energy costs.



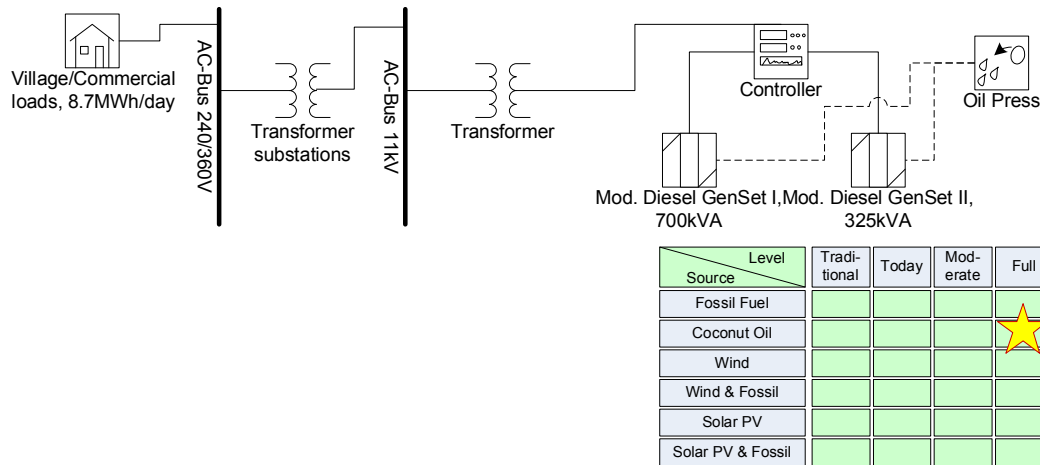

Figure 7.20: Level D: Coconut Generation Scheme.

Table 7.35: Modelling results - Level D - Coconut oil.

Initial Capital	Total NPV <sup>a</sup>	COE <sup>b</sup>	DEC <sup>c</sup>	Coconut oil
F\$3,121,094	F\$19,860,700	0.49F\$/kWh	120.50F\$/month	1198×10 <sup>3</sup> l/a

<sup>a</sup>NPV stands for Net Present Value.

<sup>b</sup>COE stands for Cost of Energy and refers to the levelized electricity cost per kWh.

<sup>c</sup>DEC stands for Domestic Energy Cost, and refers to the levelized electricity cost per household per month.

### 7.12.2 Coconut Oil Supply

The two-generator coconut oil system concept in Figure 7.20 supplies a D-level load using an average daily 3300l of coconut oil. This amount of coconut oil requires 1997t of dried copra per year. In the case of intensive coconut cultivation, this amount of copra could be produced from a land area of 400ha which is 9% of Rotuma's entire land area. Chapter 6 showed that if the resource was fully utilized, Rotuma could currently produce 1500t of dried copra per annum without new planting. Thus, a moderately scaled tree planting project would have to be initiated before such an energy system could be realized.

**Feasibility Risks**

Ident.	Description	I	P	R
Fundamental issues				
MD2.1	Engine problems due to coconut oil caused corrosion	3	2	6
Technical issues				
TD2.1	Failure of coconut oil conversion equipment due to non-standardization of equipment	3	3	9
Application issues				
ADC2.1	Repair delays due to long turnaround times	3	3	9
AD2.2	Damage to plant due to improper use	3	2	6
Cost issues				
CD2.1	Continuous financing problems	4	3	12
CD2.2	Difficulties finding initial lender due to high initial investment	5	2	10

**Resource Security Risks**

Ident.	Description	I	P	R
RD2.1	Plant repair difficulties due to 50% reduction of access trips to the island due to peak oil	3	4	12
RD2.2	Local supply problems due to dramatic rise in world coconut oil price	5	2	10
RD2.3	Supply shortage due to hurricane strike	4	3	12

**Environmental Problem Risks**

Ident.	Description	I	P	R
ED2.1	Accumulation of old machinery, excl. batteries	1	3	3
ED2.2	Large scale contamination of soil/groundwater by waste engine oil	3	1	3
ED2.3	Habitat destruction due to land requirements	3	2	6
ED2.4	Local air pollution due to engine exhausts	1	1	1
ED2.5	Noise pollution due to plant operation	1	1	1

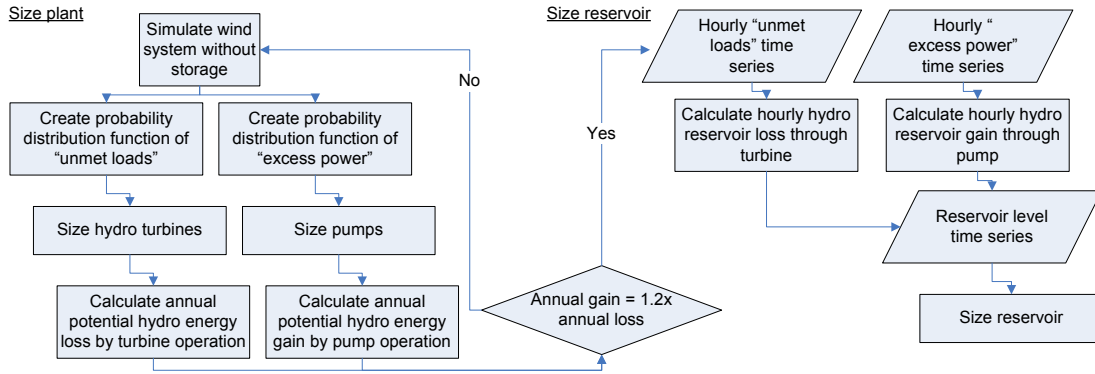

Figure 7.21: Method for modelling of wind power system with pumped storage.

### 7.12.3 Wind Power

Supplying a service level D load with wind power would be difficult because of the large number of batteries that would be required to store energy for extended periods without wind. Instead, a small pumped storage plant is proposed here. Since pumped storage cannot be directly simulated in HOMER, the system was modelled in two stages as illustrated in Figure 7.21: a hypothetical wind system is simulated in HOMER with no storage, and probability distributions exported. From probability distributions, pumps and turbines are sized. For turbines, the objective is to cover most of the range of power requirements, in this case from 75kW to 800kW. A single Ossberger type turbine can cover this range without significant drop in efficiency in part load mode. The pump is sized for utilizing the maximum amount of excess wind energy with a minimum specified operating range for the pumps. If the pumps cover a range of 350kW to 2100kW, 88% of all excess wind generation is useable by the pumps. Unmet load and excess generation distributions are shown in Figures 7.22(a) and 7.22(b). The annual cumulative reservoir gains  $E_{gain,a}$  and losses  $E_{loss,a}$  are calculated in terms of stored hydro energy to:

$$E_{gain,a} = \sum_{i=1}^n E_{excess,el,i} \cdot \eta_{pump} \cdot \eta_{penstock}, \quad (7.8)$$

and

$$E_{loss,a} = \sum_{i=1}^k \frac{E_{unmet,el,i}}{\eta_{turbine} \cdot \eta_{penstock}}, \quad (7.9)$$

where  $n$  and  $k$  signify the number of power level bins,  $\eta_{pump}$ ,  $\eta_{turbine}$ , and  $\eta_{penstock}$  pump, turbine, and penstock efficiencies. All friction losses in the penstock are summarized in this single efficiency value instead of attributing these to an increased or decreased net head. Efficiencies are assumed to be  $\eta_{pump} = \eta_{turbine} = 78\%$ , and  $\eta_{penstock} = 85\%$ . If  $E_{gain}$  is greater than  $E_{loss,a}$  by a reserve of roughly 20%, the system is assumed feasible. In order to size the reservoir, an hourly

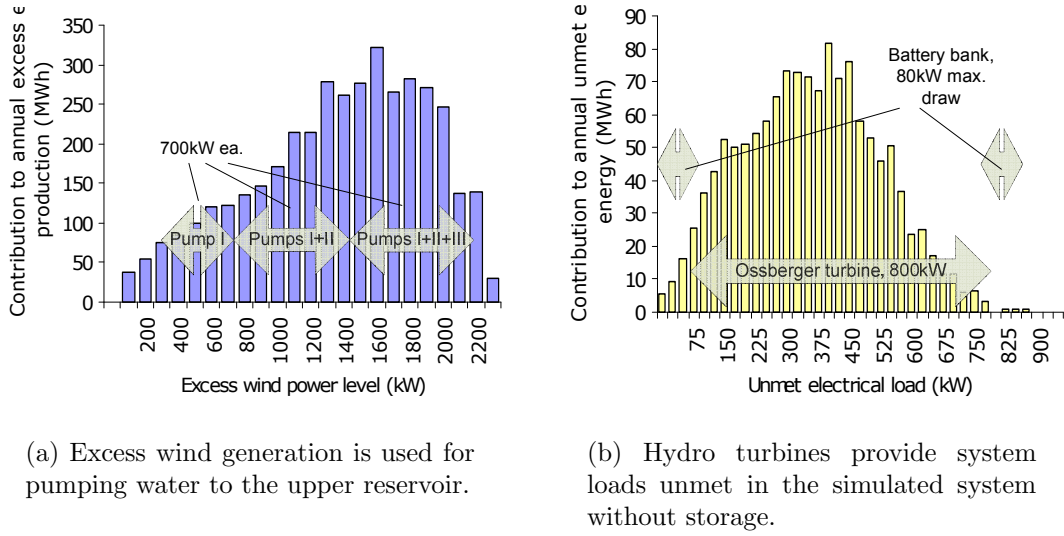

Figure 7.22: Distribution functions of excess wind generation, and unmet electric loads.

“unmet load” ( $P_{unmet}$ ) and “excess generation” ( $P_{excess}$ ) time series are exported from Homer, and converted to changes in the reservoir water level  $V_R$  in Matlab<sup>®</sup>, according to:

$$V_{R,j} = V_{R,j-1} + \frac{P_{excess,j} \cdot \eta_{pump} \cdot \eta_{penstock} \cdot 1h}{g\rho H} - \frac{P_{unmet,j} \cdot 1h}{\eta_{turbine} \cdot \eta_{penstock} \cdot g\rho H}, \quad (7.10)$$

where  $g$  is the acceleration of the earth,  $\rho$  the density of water, and  $H$  the gross head. The index  $j$  refers to the number of hour of the year, i.e. a value between 1 and 8760. Reservoir gains and losses in Equation 7.10 occur only if  $P_{excess,j}$  and  $P_{unmet,j}$  are greater than the minimum capacities of the pump or turbine as specified above, otherwise the respective terms become zero. Low power requirements are handled by the battery system. The required volume of the reservoirs  $V_{R,design}$  is the difference between the minimum and maximum water levels  $V_{R,max}$  and  $V$  plus a reserve  $R$ , expressed as a percentage over capacity:

$$V_{R,design} = (V_{R,max} - V_{R,max})(1 + R). \quad (7.11)$$

In this case, with a reserve of 20%,  $V_{R,design}$  has been calculated to  $6.85 \times 10^6 m^3$ . If the reservoir was to have a cylindrical shape and a constant depth of 35m, the storage volume would require a reservoir of 500m in diameter.

A diagram of the complete energy system with pumped storage is shown in Figure 7.23. Costs for the pumped storage plant are based on costs discussed in Section 7.5.8, for a 2100kW capacity plant. While turbine power is only 800kW, penstocks still have to be laid out for the maximum achievable water flows. Costs are summarized in Table 7.36.

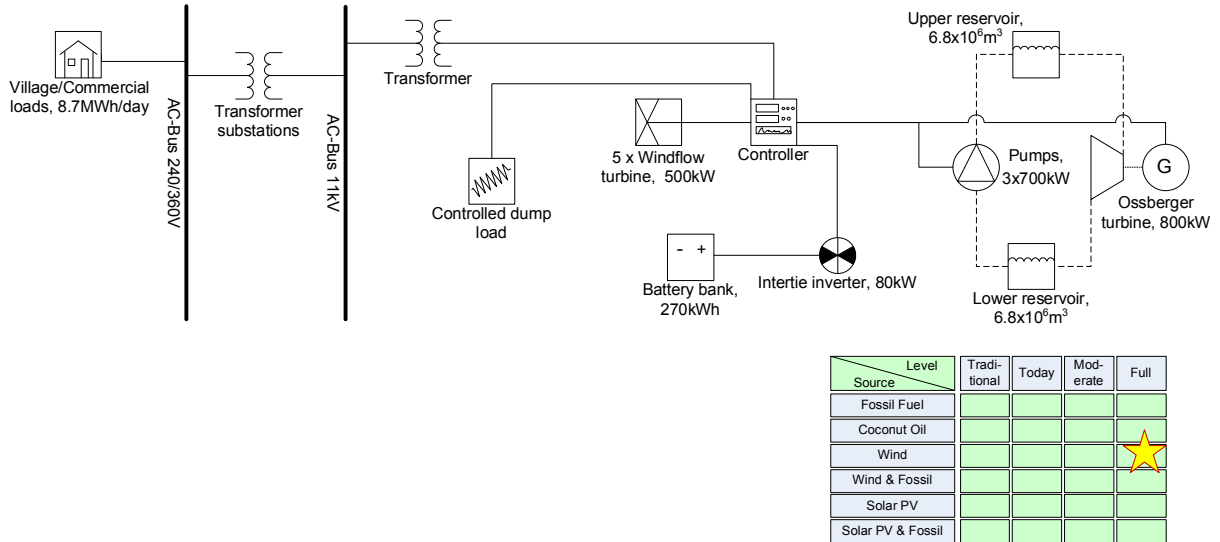

Figure 7.23: Level D: Wind generation scheme.

Table 7.36: Modelling results - Level D - Wind

Initial Capital	Total NPV <sup>a</sup>	COE <sup>b</sup>	DEC <sup>c</sup>
F\$84.34m	F\$91.64m	2.25F\$/kWh	556F\$/month

<sup>a</sup>NPV stands for Net Present Value.

<sup>b</sup>COE stands for Cost of Energy and refers to the levelized electricity cost per kWh.

<sup>c</sup>DEC stands for Domestic Energy Cost, and refers to the levelized electricity cost per household per month.

As the above analysis shows, a pumped storage system for Rotuma would be a fairly ambitious project. Trying to simplify this concept, a variation of this system was considered where high solidity mechanical wind pumps replace pumps and wind turbines. The major problem with this option is that wind pumps are not available in large diameters. The largest wind pumps available reach approximately 30m in rotor diameter. Roughly 1000 of such wind pumps would be required to supply the water requirements at the given head and the available wind speeds. Based on a quote by Aureka, an Indian wind pump manufacturer<sup>3</sup>, the installed cost of a wind pump park (exclusive penstock and plumbing costs) of this size would be in the order of F\$95,000. Even if this cost could be significantly reduced because of the high order volume, the large number of wind pumps would present a plethora of technical, environmental, and land issues.

### **Feasibility Risk**

High costs make this concept financially unfeasible. Tentatively a battery storage option was simulated, but total annualized costs were another 35% higher than for the option considered. The pumped storage plant alone accounts for 85% of the domestic energy costs with another 14% attributable to the wind turbines.

---

<sup>3</sup>The 2007 quote was for a single Aureka wind pump including 23m mast, shipped to Fiji. Total costs were extrapolated to the required no. of wind pumps.

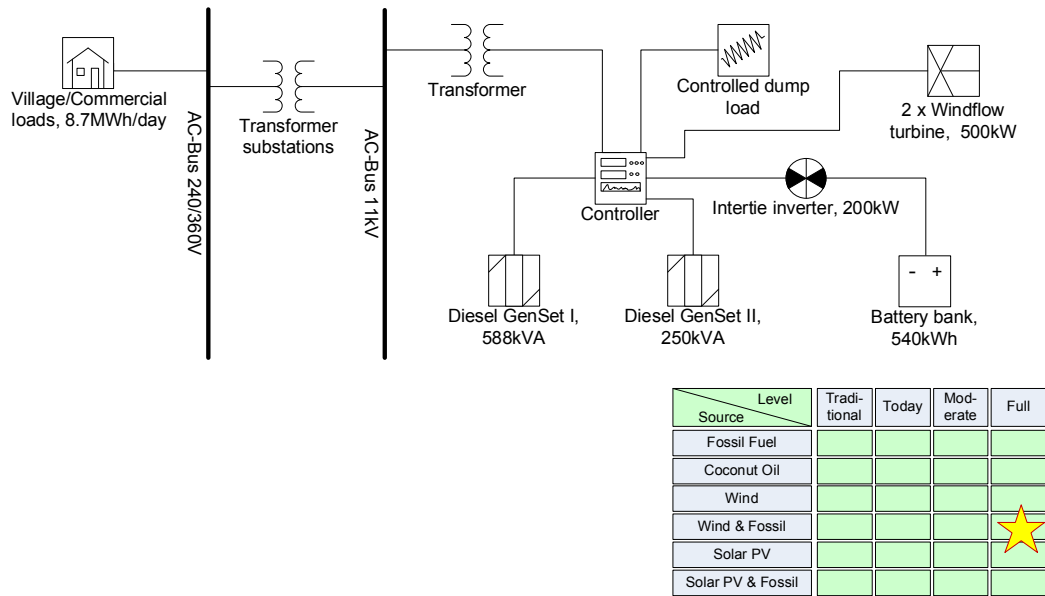

Figure 7.24: Level D: Wind diesel hybrid generation scheme.

Table 7.37: Modelling results - Level D - Wind Diesel

Initial Capital	Total NPV <sup>a</sup>	COE <sup>b</sup>	DEC <sup>c</sup>	Diesel
F\$6,391,579	F\$25,187,144	0.62F\$/kWh	152.82F\$/month	637 × 10 <sup>3</sup> l/a

<sup>a</sup>NPV stands for Net Present Value.

<sup>b</sup>COE stands for Cost of Energy and refers to the levelized electricity cost per kWh.

<sup>c</sup>DEC stands for Domestic Energy Cost, and refers to the levelized electricity cost per household per month.

### 7.12.4 Wind-Diesel Hybrid System

This concept combines two Windflow 500 wind turbines with two diesel generator sets of 588kVA and 250kVA (see Figure 7.24). A small 540kW (14t) battery bank adds power stability and short term storage. Diesel fuel savings compared to the pure diesel system are 45%. Costs are shown in Table 7.37.

**Feasibility Risks**

Ident.	Description	I	P	R
Fundamental issues				
MD4.1	Premature turbine failure due to corrosion in marine environment	3	1	3
Application issues				
TD4.1	Power quality problems due to high wind penetration	1	3	3
Application issues				
AD4.1	Repair delays due to long turnaround times	2	3	6
AD4.2	Damage to plant due to improper use	3	2	6
Cost issues				
CD4.1	Continuous financing problems	4	5	20
CD4.2	Difficulties finding initial lender due to high initial investment	5	3	15

**Resource Security Risks**

Ident.	Description	I	P	R
RD4.1	System disruptions by 50% petroleum reduction of petroleum product imports	3	5	15
RD4.2	Plant repair difficulties due to 50% reduction of access trips to the island due to peak oil	2	4	8
RD4.3	Damage of plant due to hurricane strike	3	3	9
RD4.4	Wind resource problems due to two months period of missing power winds	2	3	6



**Environmental Problem Risks**

Ident.	Description	I	P	R
ED4.1	Accumulation of old machinery, excl. batteries	1	3	3
ED4.2	Large scale contamination of soil/groundwater by waste engine oil	3	1	3
ED4.3	Soil/groundwater contamination due to petroleum fuel spills on land	4	1	4
ED4.4	Sea contamination due to petroleum fuel spills during delivery	4	2	8
ED4.5	Soil/groundwater contamination due to battery spillages	4	3	12
ED4.6	Soil/groundwater contamination due to battery dumping	5	3	15
ED4.7	Decimation of bird populations due to large wind turbines	2	3	6
ED4.8	Habitat destruction due to land requirements	3	1	3
ED4.9	Local air pollution due to engine exhausts	1	1	1
ED4.10	Noise pollution due to plant operation	1	3	3

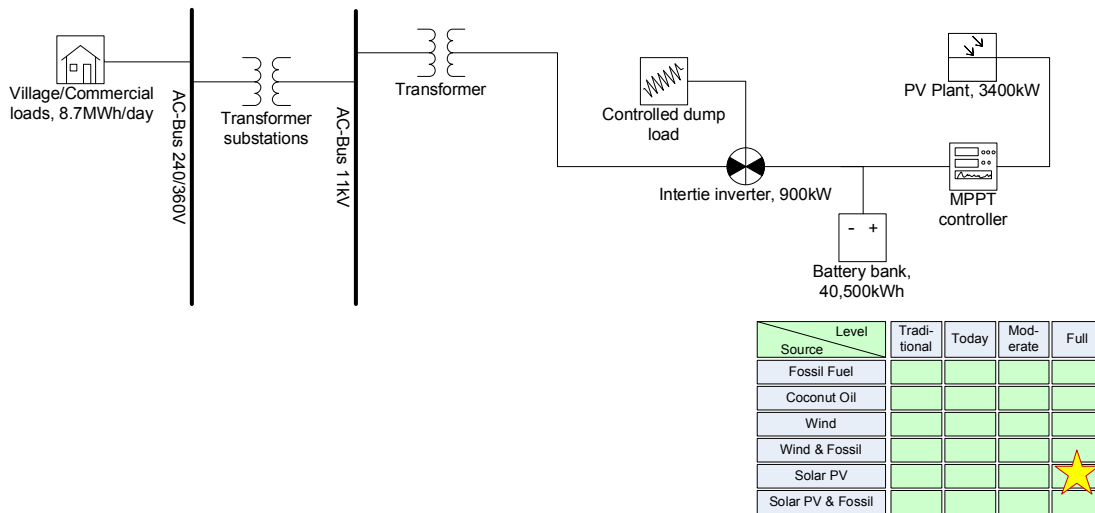

Figure 7.25: Level D: Solar PV generation scheme.

Table 7.38: Modelling results - Level D - Solar PV

Initial Capital	Total NPV <sup>a</sup>	COE <sup>b</sup>	DEC <sup>c</sup>
F\$63.26m	F\$106.98m	2.63F\$/kWh	649.10F\$/month

<sup>a</sup>NPV stands for Net Present Value.

<sup>b</sup>COE stands for Cost of Energy and refers to the levelized electricity cost per kWh.

<sup>c</sup>DEC stands for Domestic Energy Cost, and refers to the levelized electricity cost per household per month.

### 7.12.5 Solar PV

The solar PV variant of a D level energy supply system uses a 3400kW PV panel array combined with a 41MWh battery bank. The PV array requires a land area of 4.8ha, the equivalent of seven soccer fields. The battery bank weighs one million tons. While a battery bank of this size might not be technically viable, Section 7.12.3 already illustrated the difficulties and high costs with potential alternative storage systems. A pumped storage system for this concept would further increase the costs by a large margin.

#### Feasibility Risk

Very high costs render this option financially unfeasible. The high domestic energy costs are comprised mainly of the solar PV array with a contribution of 75%, and the battery bank accounting for 19% of domestic energy costs.

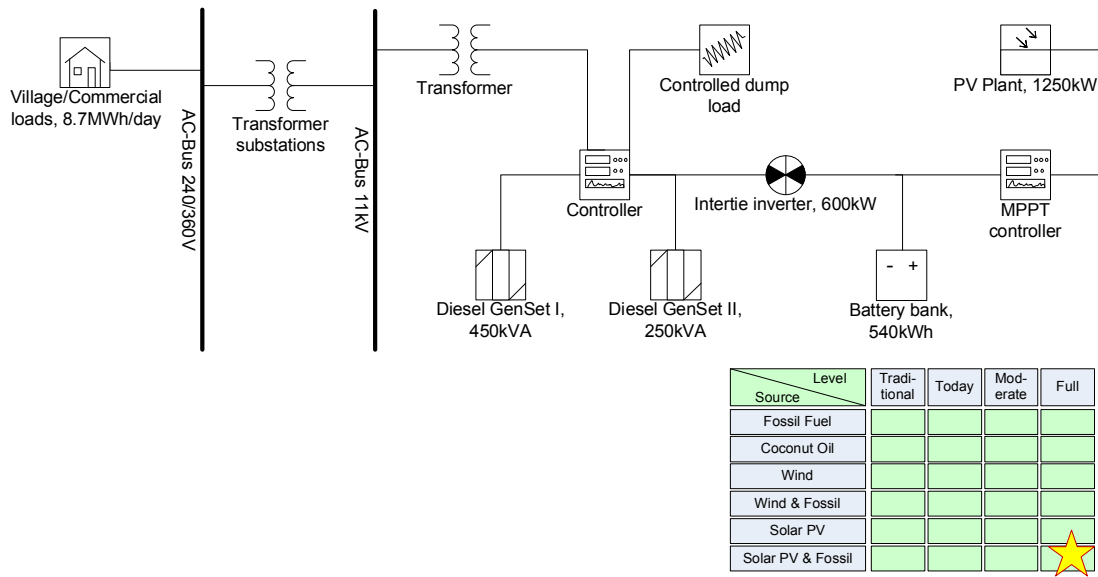

Figure 7.26: Level D: Solar PV Diesel Hybrid generation scheme.

Table 7.39: Modelling results - Level D - Solar PV Diesel

Initial Capital	Total NPV <sup>a</sup>	COE <sup>b</sup>	DEC <sup>c</sup>	Diesel
F\$21,466,204	F\$52,093,412	1.28F\$/kWh	316.08F\$/month	652 × 110 <sup>3</sup> /a

<sup>a</sup>NPV stands for Net Present Value.

<sup>b</sup>COE stands for Cost of Energy and refers to the levelized electricity cost per kWh.

<sup>c</sup>DEC stands for Domestic Energy Cost, and refers to the levelized electricity cost per household per month.

### 7.12.6 Solar PV–Diesel Hybrid System

The solar PV–diesel hybrid system option makes use of a PV array of 1,250kW or 17,350m<sup>2</sup> and two diesel generators of 450kVA and 250kVA. A relatively small 540kWh (14t) battery bank adds short term storage and power stability. Diesel fuel savings compared to the pure diesel system are 44%.

#### Feasibility Risk

The concept is not feasible due to prohibitive costs. Principle contributor to domestic energy cost is the PV array with 57%, followed by the generators inclusive diesel fuel at 33%.

Service Level Source	Traditional	Today's level	Moderate Development	Full Development
Fossil Fuel		DEC = \$12.53 \$0.94/kWh I = \$0.14m	DEC = \$91.83 \$1.06/kWh I = \$2.07m	DEC = \$196.80 \$0.80/kWh I = \$2.22m
Copra		DEC = \$10.41 \$0.78/kWh I = \$0.21m	DEC = \$77.30 \$0.89/kWh I = \$2.45m	DEC = \$120.50 \$0.49/kWh I = \$3.12m
Wind		DEC = \$52.55 \$3.96/kWh I = \$2.48m	DEC = \$308.13 \$3.56/kWh I = \$17.16m	DEC = \$556.02 \$2.25 I = 84.34m
Wind-Hybrid		DEC = \$23.71 \$1.79/kWh I = \$0.85m	DEC = \$83.12 \$0.96/kWh I = \$3.07m	DEC = \$152.82 \$0.62/kWh I = \$6.39m
Solar		DEC = \$43.73 \$3.29/kWh I = \$1.97m	DEC = \$242.02 \$2.80/kWh I = \$13.50m	DEC = \$649.10 \$2.63/kWh I = \$63.26m
Solar-Hybrid		DEC = \$25.53 \$1.92/kWh I = \$0.84m	DEC = \$139.88 \$1.62/kWh I = \$6.02m	DEC = \$316.08 \$1.28/kWh I = \$21.47m

Figure 7.27: System costs shown in the representation of the feasibility space. Shown are domestic energy costs (DEC), i.e. the household's monthly energy bill. Also shown is the normalized cost of energy and the initial investment (I) in millions of dollars.

### 7.13 Summary of Results

The previous sections presented the modelling and analysis results in detail. The modelling results were used to perform feasibility and risk analysis on the concepts. The feasibility space and energy costs of the investigated systems are shown in Figure 7.27. Concepts with prohibitive costs are marked in red. The results of the overall analysis are summarized in Table 7.40, which displays the total risk values per category. The first two categories, 'Culture' and 'Level Feasibility' are associated with the energy service level only and are thus concept independent, while the remaining three categories are energy concept dependent. The numbers of individual risks, of low, medium, or high levels are illustrated by color codes; red numbers indicate high risks. Olive numbers suggest medium risks and green numbers suggest only low level risks in a category.

Seven out of 18 concepts failed the first test of general feasibility, in these cases all because of prohibitive cost. The remaining 11 concepts are filtered according to the risk levels incurred. The following simple criterion was applied: concepts that incur two or more single high risks are considered unacceptable, leaving five concepts. The whole process of filtering out undesirable concepts is graphically illustrated in Figure 7.28. As suggested in Chapter 3, the possibility space represents the range of technically feasible concepts. The above analysis reduced this space to the feasibility space and further to the opportunity space. For Rotuma,

Table 7.40: Summary of Risk indices (ACI)

Lev.	Concept	Culture	Level feasibil- ity	Concept feasibil- ity	Resource	Enviro.	Total risk score
A	-	<b>0</b>	<b>20</b>	-	-	-	20
B	Diesel	<b>35</b>	<b>14</b>	<b>32</b>	<b>30</b>	<b>34</b>	145
	Copra	<b>35</b>	<b>14</b>	<b>66</b>	<b>22</b>	<b>23</b>	160
	Wind	<b>35</b>	<b>14</b>	<b>68</b>	<b>28</b>	<b>54</b>	199
	Wind-Hybrid	<b>35</b>	<b>14</b>	<b>50</b>	<b>40</b>	<b>59</b>	198
	Solar	<b>35</b>	<b>14</b>	<b>76</b>	<b>44</b>	<b>54</b>	223
	Solar-Hybrid	<b>35</b>	<b>14</b>	<b>63</b>	<b>42</b>	<b>70</b>	224
C	Diesel	<b>58</b>	<b>23</b>	<b>40</b>	<b>28</b>	<b>35</b>	184
	Copra	<b>58</b>	<b>23</b>	<b>60</b>	<b>26</b>	<b>26</b>	193
	Wind	<b>58</b>	<b>23</b>	$\infty$	-	-	-
	Wind-Hybrid	<b>58</b>	<b>23</b>	<b>50</b>	<b>38</b>	<b>68</b>	237
	Solar	<b>58</b>	<b>23</b>	$\infty$	-	-	-
	Solar-Hybrid	<b>58</b>	<b>23</b>	$\infty$	-	-	-
D	Diesel	<b>85</b>	<b>41</b>	$\infty$	-	-	-
	Copra	<b>85</b>	<b>41</b>	<b>52</b>	<b>34</b>	<b>34</b>	246
	Wind	<b>85</b>	<b>41</b>	$\infty$	-	-	-
	Wind-Hybrid	<b>85</b>	<b>41</b>	<b>53</b>	<b>38</b>	<b>78</b>	295
	Solar	<b>85</b>	<b>41</b>	$\infty$	-	-	-
	Solar-Hybrid	<b>85</b>	<b>41</b>	$\infty$	-	-	-

five regional system concepts represent the real development opportunities for Rotuma.

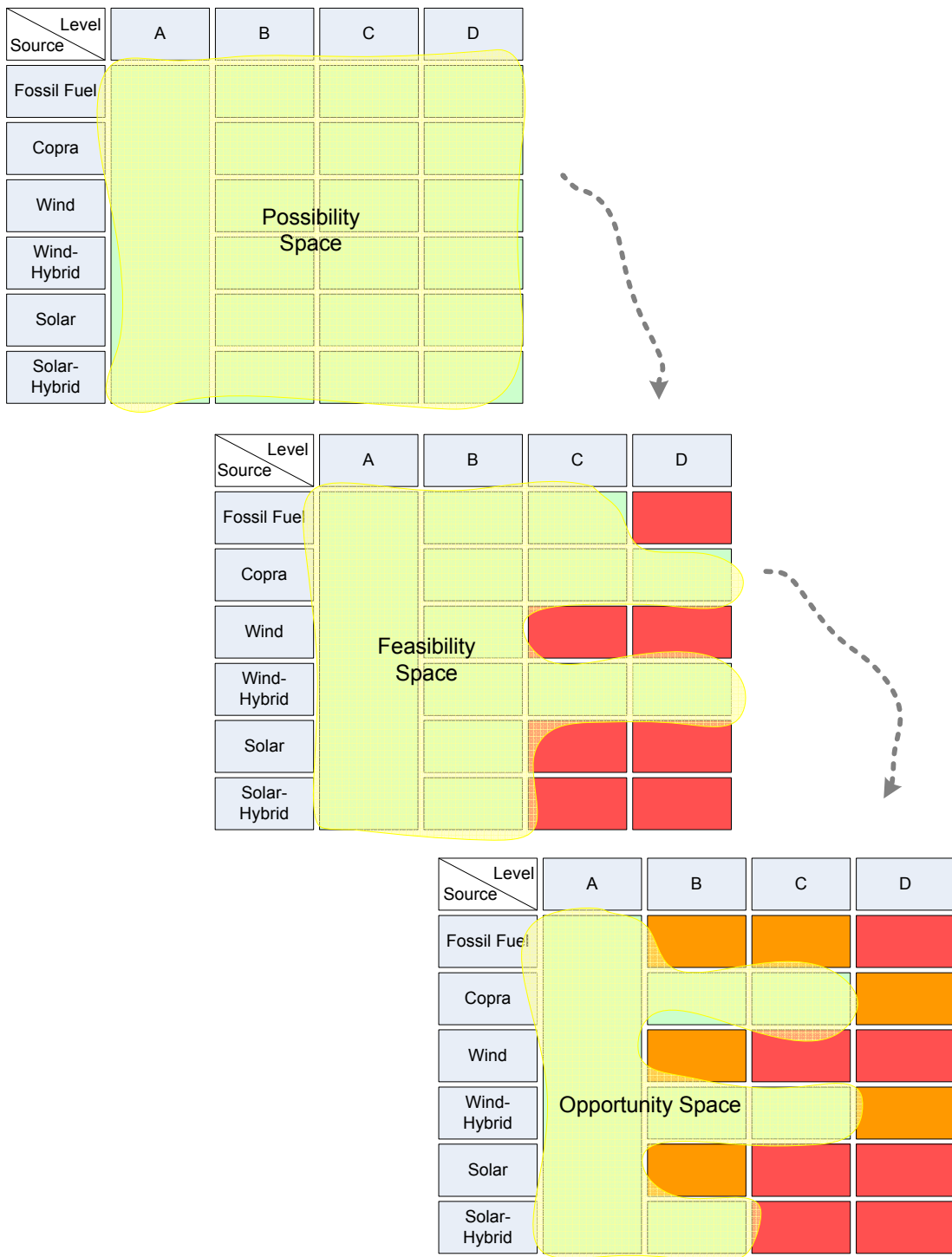

Figure 7.28: Graphic representation of ESI matrix for Rotuma.

## Chapter 8

# Performance Objective Design Considerations

The last chapter set out the space of technically feasible regional energy system options. This ‘possibility space’ was described by 18 reference energy systems. Each reference energy system was modelled and optimized for the least cost (net present cost) configuration of components. Feasibility and risk analysis reduced the possibility space to the ‘opportunity space’. The actual performance objective design is not part of this thesis, however, the subsequent sections demonstrate how the preceding results could be employed in the design phase. The chapter is rounded off with a discussion of the differences of the Anthropogenic Continuity Planning (ACP) approach and standard energy planning methods.

### 8.1 Decision Making and Design

The results from the risk analyses are visually summarized in the graphic representation of the opportunity space. This combined with the documentation of modelling and risk analysis is transferred to the decision maker. These documents are expected to assist the decision maker to reach an informed decision regarding the target energy service level for Rotuma. The decision making process is illustrated in Figure 8.1. Of course, the energy service level is not purely limited to either of the three idealized reference levels of the opportunity space. The consensus of the decision maker allows the energy engineer to enter the performance objective design phase, where an energy supply system is optimized to suit the target energy service level. The performance objective design follows five steps:

1. System requirements
2. Design supply system
3. Model, simulate and optimize



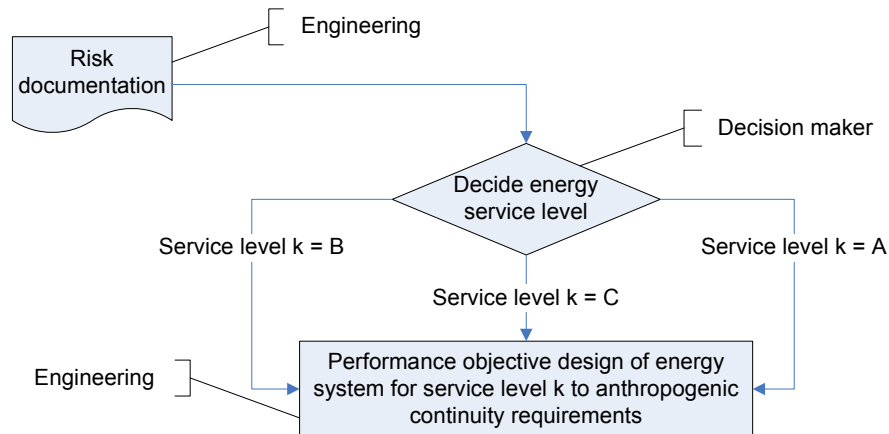

Figure 8.1: Suggested context of decision making in ACP approach.

4. Risk analysis
5. Final decision making

For illustrative purposes, it is assumed that the Council of Chiefs of Rotuma decided for a level B energy system. The most likely candidate solutions for an energy system are any applicable concepts or combinations thereof from the opportunity space. The performance objective design steps above are illustrated in line with this example:

### Step 1—Regional energy system requirements

Energy demand patterns for a B energy service level were established in the previous chapter. The first step of the performance objective design is to collect system requirements posed by the desired energy services and the energy supply options; For Rotuma, three options of the opportunity space match a B service level: coconut oil, wind-hybrid, and solar-hybrid systems, coconut generation being the overall cheapest.

### Step 2—Design

The design step describes the creative process of finding suitable energy service/energy supply system solutions, for example wind turbines with batteries to supply a particular set of services.

### Step 3—Modelling

The options are modelled and performance is simulated.

**Step 4—Risk analysis**

Using the same process as in the previous chapter, candidate solutions are subjected to feasibility and comparative risk assessment. Risks are assessed by the same criteria as in the previous chapter, and are thus comparable to the results of the above risk assessment.

**Step 5—Decision making**

The decision making process is best compared to architectural designs. Designs are created and adapted in an iterative process between the clients (in this example decision makers) and engineers.

The most promising concept idea for Rotuma is based on coconut generation, due to its low cost, comparably low risks, and added benefits of other potential uses of coconut oil.

## 8.2 ACP Approach vs. Standard Energy Planning

This section is devoted to contemplate some of the differences in results of traditional planning methods and the ACP approach. The comparison is summarized in Table 8.1 and explained in more detail below.

The most notable difference is a shift in the principal planning objective: traditionally energy planning employs economic assessment tools such as cost benefit analysis, in order to optimize economic growth, while sustainability aspects become internalized costs (e.g. Triple Bottom Line) or are treated as ethical issues on the side. In contrast, the ACP method seeks out sustainable solutions in the first place while rendering economic benefits secondary. The result is that economic growth and anthropogenic continuity swap places in the planning hierarchy. In other words, customary methods include economic growth as prerequisite and sustainability constraints as options, the new method takes sustainability as prerequisite and economic growth as option, by no means necessary for good functioning of the system. While in the first case sustainability may sometimes not be achievable (compare for example Graedel (2003)), economic growth may just not be achievable if the ACP approach is used.

By involving people in the search for reference energy service levels by means of the aspirations survey, the ACP method marks a step away from the market focus of traditional approaches.

While traditional approaches generally encourage raising energy service levels, an important component of economic growth, the ACP method inherently inclines towards more secure, lower impact energy service levels which are often more conducive to anthropogenic continuity.

Table 8.1: Comparison of ACP Method with traditional method.

Parameter	Trad. Method	ACP Method
Economic growth	Main planning objective	Optional
Anthropogenic continuity	Optional	Main planning objective
Project development focus	Marketplace	People
Energy and other resource consumption	Inherently high	Inherently low
Energy service level	higher	lower
Influence of general public on decision making	Inherently low	Interently high

# Chapter 9

## Conclusions

This thesis set out with the aim to develop an approach to regional energy engineering, where sustainability informs engineering at the highest priority level. The outcome of this work is the Anthropogenic Continuity Planning (ACP) approach and its application to Rotuma Island. The ACP approach led to results that would not normally have been conceived of using standard methodologies.

Conventional energy engineering as well as sustainability approaches were reviewed in Chapter 2; despite many technical and energy management innovations in the aftermath of the 1973 OPEC oil embargo (most importantly energy efficiency and demand side management (DSM)), environmental problems did not decline. Many approaches to sustainability exist, but are often not tangible and thus only partly useful for planners and engineers. Other sustainability concepts were shown to rely on unrealistic expectations of engineering to solve severe environmental problems.

This thesis aimed to fill a notable communication gap between conceptual sustainability and real world engineering. Krumdieck's theoretical model was employed in Chapter 3 to illustrate an important recognition: the built environment is the primary determinant of anthropogenic continuity, because the engineered environment frames the context of our day to day activities; this led to the conclusion that the engineer's part in an envisioned multidisciplinary approach to sustainability should be to design the built environment in such a way that it could be operated in a sustainable way. It is thus recognized that anthropogenic continuity needs to enter the engineering processes. Chapter 3 proposed ACP as a strategic approach to investigate how different regional energy system designs would effect anthropogenic continuity.

The general introduction to geography and life on the island in Chapter 4 led to an in-depth coverage of energy survey results (Chapter 5) as well as energy resources available there (Chapter 6). Thus well prepared for the analysis, the steps of the new ACP approach were implemented in Chapter 7 and led to the resulting opportunity space for Rotuma island. The graphical representation of the opportunity space is seen as a crucial communication link to the interested

community and decision makers.

On Rotuma there is a great deal of discussion about energy options, but there is also a lot of confusion as to what is possible and what is best suited to fulfill their needs without taking away what they value. The opportunity space is an easily understood means of informing and focusing community discussion. The underlying analysis is transparent, straightforward and accessible even to the layman. As the case may be, the analysis is easily adapted to changing surrounding conditions. In a comparison with existing energy planning approaches, Chapter 8 puts the new ACP method in perspective. As a principal difference, the ACP method subjugates macro-economic considerations, most notably economic growth, to anthropogenic continuity requirements.

This necessary step has wide ranging implications and is hoped to inspire urgently needed research in many disciplines; if, for example economic growth is no longer possible, alternative economic models may have to be employed. While the ACP method is only an initial attempt at anthropogenic continuity, the thesis developed, proposed and demonstrated an alternative and directly useable approach of regional planning for sustainability. The ACP method represents a viable means of linking sustainability to energy engineering.

# Chapter 10

## Future Work

Within the scope of this thesis, the new anthropogenic continuity planning (ACP) approach was demonstrated by means of a relatively simple case study with a low level of energy services. While the ACP approach is generally applicable to any region, further research is required into the methodological framework of application to complex and developed regions, such as urban areas in New Zealand.

While the ACP approach can be employed to identify sustainable regional energy systems, further research needs be directed towards its technical and also social implementation. This is of particular importance if the sustainable regional energy system is very different from the existing system. Collaboration with ecological economists<sup>1</sup> is needed in order to adapt existing economies to the shifted opportunities posed by sustainable regional energy systems.

In this thesis, risk parameters and valuations were developed by the author. Especially in context of more complex regions, the risk analysis should be placed in the hands of experts in the respective fields. For example resource security risks could be more effectively analyzed by petroleum or renewable energy analysts. It is thus important that avenues of effective interdisciplinary collaboration be developed.

At last there are opportunities to carry the Rotuma study further. It would be appropriate to send a delegation from the Department of Mechanical Engineering back to Rotuma in order to present the results and to carry out the final design of an energy system based on an informed decision directive from Rotuma's leaders. If this could be agreed on by the Council of Chiefs, Rotuma could become the first region for the ACP approach to be implemented. There are mutual benefits vested in potential future collaboration between the University of Canterbury and Rotuma.

---

<sup>1</sup>Ecological Economics is an emerging branch of neoclassical economics which breaks with its mother discipline on the understanding of constraints. Ecological Economics rejects the requirement for economic growth. A first textbook on Ecological Economics was published by Daly and Farley (2004)

# Bibliography

- Ackoff, R.: 1981, *Creating the Corporate Future*, Wiley, New York.
- Agency: n.d., *Technical report*.
- Archer, C. L. and Jacobson, M.: 2005, Evaluation of global wind power and interconnected wind farms, *American Geophysical Union, Fall Meeting 2005*, American Geophysical Union.
- Baring-Gould, E. I.: 2003, The national renewable energy laboratory hybrid system modeling suite, *Technical report*, National Renewable Energy Laboratory.
- Beckman, W. and Duffie, J.: 1980, *Solar Engineering of Thermal Processes*, Wiley-Interscience, New York.
- Bennett, P., Bryant, J. and Howard, N.: 2001, Drama theory and confrontation analysis, *Rational Analysis for a Problematic World Revisited: Problem Structuring Methods for Complexity, Uncertainty and Conflict.*, Wiley, Chichester, pp. 225–248.
- Bossel, H.: 1999, *Indicators for sustainable development*, International Institute for Sustainable Development, Winnipeg, Canada.
- Bowen, A. J. and Mortensen, N. G.: 1996, Exploring the limits of wasp: the wind atlas analysis and application program, *European Union Wind Energy Conference and Exhibition*, Gteborg, Sweden, pp. 584–587.
- Bruckner, T.: 2001, Benutzerhandbuch deeco version 1.0, *Technical report*, Institut für Energietechnik, Technische Universität Berlin, Germany.
- Bruckner, T., Morrison, R., Handley, C. and Patterson, M.: 2003, High-resolution modeling of energy-services supply systems using deeco : overview and application to policy development., *Annals of Operations Research* **121**(1 - 4), 151180.
- Brundtland-Commission: 1987, *Our common future*, Oxford University Press, Oxford ; New York.

- BURGEAP: 2006, Pacific subregional: Renewable energy and energy efficiency programme (reep), volume i: Program activities, *Technical report*, Report for the Asian Development Bank.
- Campbell, C. J.: 1997, *The Coming Oil Crisis*, Multi-Science Publishing Co. Ltd, Essex, UK.
- Campbell, C. J.: 2003, Industry urged to watch for regular oil production peaks, depletion signals, *OGJ July 2003*.
- Campbell, C. J. and Laherrere, J.: 1998, The end of cheap oil (vol 278, pg 77, 1998), *Scientific American* **278**(6), 78–83. Times Cited: 0 Correction English Cited References Count: 1 Zn937.
- CEEESA: 2005, Enpep website, *Technical report*, <http://www.dis.anl.gov/CEEESA/ENPEPwin.html>, May 2005.
- Checkland, P. and Poulter, J.: 2006, *Learning for Action: A short definitive account of Soft Systems Methodology and its use for Practitioners, teachers and Students*, Wiley, Chichester.
- CIDA: 2004, Feasibility study on setting up of a coconut wood mill in savusavu, vanua levu, fiji, *Technical report*, CIDA.
- Collins, N., Berry, L. and Braid, R.: 1985, Past efforts and future directions for evaluating state energy conservation, *Technical Report ORNL-6113*, Oak Ridge National Laboratory.
- Daly, H. E. and Farley, J.: 2004, *Ecological Economics - Principles and Applications*, Island Press, Washington, DC.
- Dantas, A., Krumdieck, S. and Page, S.: 2006, Energy risk to activity systems as a function of urban form, *Technical report*, Land Transport New Zealand.
- Dawe, P.: 2001, Review of the rotuma water supply and distribution system, Fiji Islands, *Technical Report Preliminary Report 131*, SOPAC, Water Resource Unit.
- Deffeyes, K. S.: 2001, *Hubbert's peak : the impending world oil shortage*, Princeton University Press, Princeton, N.J.
- Diamond, J. M.: 2005, *Collapse : how societies choose to fail or succeed*, Viking, New York.
- Duic, N. and Carvalho, M. d. G.: 2004, Increasing renewable energy sources in island energy supply: case study porto santo, *Renewable and Sustainable Energy Reviews* **8**, 383 – 399.



- Duncan, R. C. and Youngquist, W.: 1999, Encircling the peak of world oil production, *Natural Resources Research* **8**, 219–232.
- Eason, William, J. E. (ed.): 1951, *A short history of Rotuma*, Government Printing Department, Suva.
- Elkington, J.: 1998, *Cannibals With Forks: The Triple Bottom Line of 21st Century Business*, New Society Publishers, Gabriola Island, BC.
- Elliott, D. L., Holladay, C. G., Barchet, W. R., Foote, H. P. and Sandusky, W. F.: 1986, *Wind Energy Resource Atlas of the United States*, Solar Technical Information Program, Golden, CO, USA.
- Elms, D.: 1998, *Owning the Future*, Centre for Advanced Engineering, Christchurch, New Zealand.
- Fairbairn, P. L.: 1998, A regional view towards sustainable renewable energy development in the south pacific, *Technical Report MR 311*, SOPAC.
- Fink, A.: 2006, *How to conduct surveys*, 3rd. edition edn, Sage Publications Inc., Thousand Oak, CA.
- Fishbone, L. G. and Abilock, H.: 1981, Markal, a linear-programming model for energy-systems analysis - technical description of the bnl version, *International Journal of Energy Research* **5**(4), 353–375.
- Fiu, M.: 2003a, Lāje Rotuma coral reef survey report, *Technical report*, Global Coral Reef Monitoring Network (GCRMN).
- Fiu, M.: 2003b, Rotuma social and economic report, *Technical report*, Lāje Rotuma Initiative.
- Freeman, S. D., Baldwin, P., Canfield Jr, M., Carhart, S., Davidson, J., Dunkerley, J. and Eddy, C.: 1974, *A Time to Choose*, Ballinger Publishing Co., Cambridge, MA.
- Gill, S. A.: 1971, Rotuma water supply, *Technical Report BP 8-12*, Fiji Geological Survey Note.
- Goodstein, D.: 2004, *Out of gas - the end of the age of oil*, W.W.Norton.
- Gowen, M. M. and Wade, H.: 1985, *Renewable Energy Assessments - An Energy Planners Manual*, East-West Center, Honolulu, HI, USA.
- Graedel, T. E. and Allenby, B. R.: 1995, *Industrial ecology*, Prentice Hall, Englewood Cliffs, N.J.

- Graedel, T. E. and Allenby, B. R.: 1998, *Industrial ecology and the automobile*, Prentice Hall, Upper Saddle River, NJ.
- Graedel, T. E. and Allenby, B. R.: 2003, *Industrial ecology*, Prentice-Hall international series in industrial and systems engineering, 2nd edn, Prentice Hall, Upper Saddle River, N.J.
- Groscurth, H. M.: 1998, *Long-Term Integration of Renewable Energy Sources into the European Energy System*, Physica-Verlag, Heidelberg.
- Grundfos: 2006, Grundfos data booklet, sp a, sp, submersible pumps, motors and accessories, *Technical Report V7023747*, Grundfos A/S.
- Harnden, R.: 1990, The languaging of models: The understanding and communication of models with particular reference to stafford beer's cybernetic model of organization structure, *Systems Practice* **3**(3), 289–302.
- Hawken, P.: 1993, *The ecology of commerce : a declaration of sustainability*, 1st edn, HarperBusiness, New York, NY.
- Hawken, P., Lovins, A. B. and Lovins, H.: 1999, *Natural capitalism : creating the next industrial revolution*, Little, Brown and Co., Boston.
- Heijungs, R., Guinee, J. B., Huppes, G., Lankreijer, R., De Haes, U., A., W. S., Ansems, A., Eggels, P., van Duin, R. and de Goede, H. P.: 1992, *Environmental life cycle analysis of products: backgrounds, 130 pp. and Guide, 96 pp.*, Centre of Environmental Science, Leiden University.
- Heinberg, R.: 2003, *The party's over : oil, war and the fate of industrial societies*, New Society Publishers, Gabriola, B.C.
- Herring, H.: 2000, Why energy efficiency is not enough, *International Workshop on Advances in Energy Studies*, Vol. 20, SGE, Porto Venere, Italy, pp. 349–359.
- Hill, T. and Westbrook, R.: 1997, Swot analysis: Its time for a product recall, *Long Range Planning* **30**(1), 46–52.
- Hirsch, R., L., Bezdek, R. and Wendling, R.: 2005, Peaking of world oil production: Impacts, mitigation, & risk management, *Technical report*, U.S. Department of Energy, National Energy Technology Laboratory.
- Hoffert, M. I., Caldeira, K., Benford, G., Criswell, D. R., Green, C., Herzog, H., Jain, A. K., Kheshgi, H. S., Lackner, K. S., Lewis, J. S., Lightfoot, H. D., Manheimer, W., Mankins, J. C., Mauel, M. E., Perkins, L. J., Schlesinger, M. E., Volk, T. and Wigley, T. M. L.: 2002, Advanced technology paths to global climate stability: Energy for a greenhouse planet, *Science* **298**(5595), 981–987.

- Holmgren, D.: 2002, *Permaculture: Principles and Pathways Beyond Sustainability*, Holmgren Design Services.
- Hubbert, M. K.: 1956, Nuclear energy and the fossil fuels, *Technical Report 95*, Shell Development Company, Extraction and Production Research Division.
- Huber, P. W.: 1999, *Hard green : saving the environment from the environmentalists : a conservative manifesto*, Basic Books, New York.
- Ieli, I.: 1991, History, superstition and religion, *Rotuma Precious Land*, Institute of Pacific Studies of the University of the South Pacific, Suva.
- Jelinski, L. W., Graedel, T. E., Laudise, R. A., Mccall, D. W. and Patel, C. K. N.: 1992, Industrial ecology - concepts and approaches, *Proceedings of the National Academy of Sciences of the United States of America* **89**(3), 793–797.
- Jenkins, J. C.: 2005, *The Humature Handbook: A Guide to Composting Human Manure, Third Edition*, Jenkins Publishing, PA.
- Johnston, P., Vos, J. and Wade, H.: 2004, Pacific regional energy assessment 2004 - fiji national report, *Technical report*, SPREP.
- Krumdieck, S.: 2007, Feedback control model of regional energy systems, *IPENZ engineering TreNZ* **2007-002**.
- Kunstler, J. H.: 2005, *The Long Emergency: Surviving the End of the Oil Age, Climate Change, and Other Converging Catastrophes of the Twenty-first Century*, Atlantic Monthly Press.
- Lane, D.: 2000, Should system dynamics be described as a hard or deterministic systems approach?, *Systems Research and Behavioural Science* **17**, 3–22.
- Leng, G. J.: 1998, *Renewable energy technologies project assessment tool: RETScreen*, CANMET Energy Diversification Research Laboratory, Varenne, Canada.
- Lindfors, L. G., Christiansen, K., Hoffman, L., Virtanen, Y., Juntilla, V., Hanssen, O.-J., Ronning, A., Ekvall, T. and Finnveden, G.: 1995, The nordic guidelines on life-cycle assessment, *Technical Report Nord 1995:20*, Nordic Council of Ministers.
- Lomborg, B.: 2001, *The skeptical environmentalist : measuring the real state of the world*, Cambridge University Press, Cambridge ; New York.
- Lundsager, P. and Baring-Gould, E. I.: 2005, Isolated systems with wind power, in T. Ackermann (ed.), *Wind Power in Power Systems*, Wiley, West Sussex, England.

- Lynch, M. C.: 2003, Petroleum resources pessimism debunked in hubbert model and hubbert modelers' assessment., *Oil and Gas Journal* **July 2003**.
- Manolakos, D., Papadakis, G., Papantonis, D. and Kyritsis, S.: 2004, A stand-alone photovoltaic power system for remote villages using pumped water energy storage, *Energy* **29**, 57 – 69.
- Marcuse, W. L., Bodin, E., Cherniavsky, E. and Sanborn, Y.: 1976, A dynamic time dependent model for the analysis of alternative energy policies, *Operational Research* .
- Mason, R. and Mitroff, I.: 1981, *Challenging Strategic Planning Assumptions*, Wiley, New York.
- Matakiviti, A. and Pham, T.: 2003, Review of the 1993 fiji government rural electrification policy, *Technical Report TR 368*, SOPAC.
- Meadows, D. H. and Meadows, D. L.: 1972, *The limits to growth; a report for the Club of Rome's project on the predicament of mankind*, Universe Books, New York,.
- Meadows, D. H., Randers, J. and Meadows, D. L.: 2004, *The limits to growth : the 30-year update*, Chelsea Green Pub., White River Junction, Vt.
- Mingers, J. and Rosenhead, J.: 2004, Problem structuring methods in action, *European Journal of Operational Research* **152**(2004), 530–554.
- Nadel, S. and Geller, H.: 1996, Utility dsm - what have we learned? where are we going?, *Energy Policy* **24**(4), 289–302.
- Norman, W. and MacDonald, C.: 2003, Getting to the bottom of "triple bottom line", *Business Ethics Quarterly* .
- Page, J. K.: 1964, The estimation of monthly mean values of daily total short-wave radiatin on vertical and inclined surfaces from sunshine records for latitudes 40degn-40degs, *UN conference on new sources of energy*, Vol. 4, p. 378.
- Palm, W. J.: 2000, *Modelling, Analysis, and Control of Dynamic Systems*, John Wiley & Sons Inc., New York.
- Phillips, L.: 1989, People-centered group decision support, in L. F. M. G. Doukidis, G. (ed.), *Knowledge-Based Management Support Systems*, Ellis-Horwood, Chichester, pp. 208–224.
- Pichel, J. W.: 2006, China's solar push more than just low-cost?, *Renewable Energy Access* .

- Rees, W. E. and Wackernagel, M.: 1994, Ecological footprints and appropriated carrying capacity: measuring the natural capital requirement of the human economy., in A. Jansson, M. Hammer, C. Folke and R. Costanza (eds), *Investing in natural capital: The ecological economics approach to sustainability*, Island Press, Washington DC.
- Rensel, J.: 1993, Migrant involvement in the economy of rotuma, *Pacific Viewpoint* **34**, 215–240.
- Rensel, J.: 1997, From thatch to cement: Social implications of housing change on Rotuma, in J. Rensel and M. Rodman (eds), *Home in the Islands: Housing and Social Change in the Pacific*, University of Hawaii Press, Honolulu.
- Robèrt, K. H.: 2000, Tools and concepts for sustainable development, how do they relate to a framework for sustainable development, and to each other?, *The Journal of Cleaner Production* **2000**(8), 243–54.
- Rotmans, J., vanAsselta, M. and Vellingab, P.: 2000, An integrated planning tool for sustainable cities, *Environmental Impact Assessment Review* **20**(2000), 265276.
- Rotuma-District-Office: 1935, Outwarf letters: Annual report, *Technical report*.
- Schoemaker, P.: 1998, Scenario planning: A tool for strategic thinking, in R. Dyson and F. O'Brien (eds), *Strategic Development: Methods and Models*, Wiley, Chichester, pp. 185–208.
- Simpson, A.: 1978, Rotuma groundwater supply, *Technical Report Note BP18/3*, Mineral Resources Division, Suva, Fiji.
- Siwatibau, S.: 1981, Rural energy in fiji: A survey of domestic rural energy use and potential., *Technical Report IDRC-175E*, International Development Research Center.
- Skrebowski, C.: 2004, Oil field mega projects - 2004, *Petroleum Review* **January 2004**. He did peak oil forecast : 2007 (Hirsch).
- Statistics: n.d., *Technical report*.
- Stockholm-Environment-Institute: 2005, Long-range energy alternatives planning system - user guide for leap 2005, *Technical report*, Stockholm Environment Institute (SEI).
- Tainter, J. A.: 1990, *The Collapse of complex societies*, New studies in archaeology, 1st paperback edition. edn, Cambridge University Press, Cambridge, Cambridgeshire; New York.

- Trist, E. and Murray, H.: 1993, The social engagement of social science - a tavistock anthology, *The Socio-Technical Perspective*, Vol. II, University of Pennsylvania Press, Philadelphia, PA.
- Turner, W. C.: 2001, *Energy management handbook*, 4th edn, Fairmont Press ; Distributed by Marcel Dekker, Lilburn, GA New York.
- Ulrich, W.: 2000, Reective practice in the civil society: The contribution of critically systemic thinking., *Reflective Practice* 1 1(2), 247268.
- Upham, P.: 2000, An assessment of the natural step theory of sustainability, *Journal of Cleaner Production* 8, 445454.
- Vera, G. J.: 2000, Renewables for sustainable village power supply, *IEEE Winter Power Meeting*, Singapore.
- von Weizsäcker, E., Lovins, A. and Lovins, L. H.: 1998, *Factor Four-Doubling Wealth, Halving Resource Use*, Earthscan Publication LTD, London.
- Weaver, P., Jansen, L., van Grootvelt, G., van Spiegel, E. and Vergragt, P.: 2000, *Sustainable Technology Development*, Greenleaf Publishing, Sheffield, UK.
- Weston, K. C.: 1992, *Energy Conversion*, West Publishing Company, St. Paul, MN.
- Wies, R. W., A, J. R. and Agrarwal, A. N.: 2005, Life cycle cost analysis and environmental impacts of integrating wind turbine generators(wtgs') into stand-alone hybrid power systems., *WSEAS Transactions on Systems* 4(9), 1383–1393.
- Woodhall, D.: 1987, *Geology of Rotuma*, Mineral Resources Department, Ministry of Lands, Energy & Mineral Resources, Suva, Fiji.
- World-Bank: 1992, Pacific regional energy assessment, *Technical Report 1*, UNPEDP, World Bank.
- Zieroth, G.: 2003, Grid connected photovoltaic electricity supply on Tokelau, part 1 - hardware specification feasiability report, *Technical report*, SOPAC.

# Appendix A

## Glossary

This list provides an alphabetic glossary of terms which have been used in the context of the Anthropogenic Continuity Planning approach.

Term	Meaning
Anthropogenic Continuity	The ability of a regional anthropogenic system (society) to continue indefinitely without major interruptions (e.g. significant resource shortfalls, economic collapse, starvation, or civil wars)
Feasibility Space	A subset of the possibility space; the range of options that are financially feasible
Opportunity Space	A subset of the possibility space; the range of regional energy system options representing realistic and low risk development opportunities
Possibility Space	The whole range of regional energy system options that is technically feasible and desirable by any significant portion of the population
Reference Energy Service Demand	Demand of energy services that is characteristic for a particular built environment; the reference energy service demand is expressed in four energy service levels. As a useable modelling input, the reference energy service demand is translated to a load curve.
Reference Built Environment	Built environment that is representative for a particular way of life. The aspirations survey identifies categories of aspirations, and built environments that supply the services resulting from these aspirations.

Reference Energy System	Energy system that is representative for a particular reference built environment
Regional Energy System	The system of energy service and supply thereof within a geographical region



# Appendix B

## List of Acronyms

AC	Alternating current
ACP	Anthropogenic continuity Planning
CMB	Cagi Ma Ba (the main supply boat to Rotuma)
COE	Cost of Energy
DEC	Domestic Energy Cost
DC	Direct current
DoE	Fiji Department of Energy
DSM	Demand Side Management
EEZ	Exclusive Economic Zone
HVAC	Heating, Ventilation, and Air Conditioning
NPC	Net Present Cost, also commonly referred to as Life Cycle Cost
O&M	Operation and Maintenance
PV	Photovoltaics
PWD	Public Works Department
SOPAC	South Pacific Geoscience Commission

## **Appendix C – Homer Models and Outputs**

### ***I. Description of Homer – NREL Background Paper***

***II. Detailed description of Homer modeling process for one of the case studies – Level B – diesel supply***

***III. Homer details and modeling outputs for all 18 case studies***

A background book section with detailed description of the Homer modeling suite is available for free to download from the internet at:

<http://www.mistaya.ca/products/homer.htm>

Accessed: 15-November, 2007

## MICROPOWER SYSTEM MODELING WITH HOMER

By:

TOM LAMBERT  
Mistaya Engineering Inc.  
and  
PAUL GILMAN and PETER LILIENTHAL  
National Renewable Energy Laboratory

Published in: *Integration of Alternative Sources of Energy*, by F. Farret and M. Simões.

Copyright © 2006 by  
John Wiley & Sons, Inc.

## **Appendix C – Homer Models and Outputs**

- I. Description of Homer – NREL Background Paper*
  
- II. Detailed description of Homer modeling process for one of the case studies – Level B – diesel supply*
  
- III. Homer details and modeling outputs for all 18 case studies*

## Homer Modeling Process

This document serves as a documentation and guideline for the general modeling procedure in Homer which was followed for the simulation of all case systems in this thesis. The procedure is explained by means of a simple system configuration in this case the diesel generator based system for service level B.

In Homer, the main window for system specification is accessed through the Add/Remove button in the left hand pane of the window. All relevant system components are selected. In this example, a system load (Primary Load) is selected and a generator (Generator 1), as shown in the figure below.

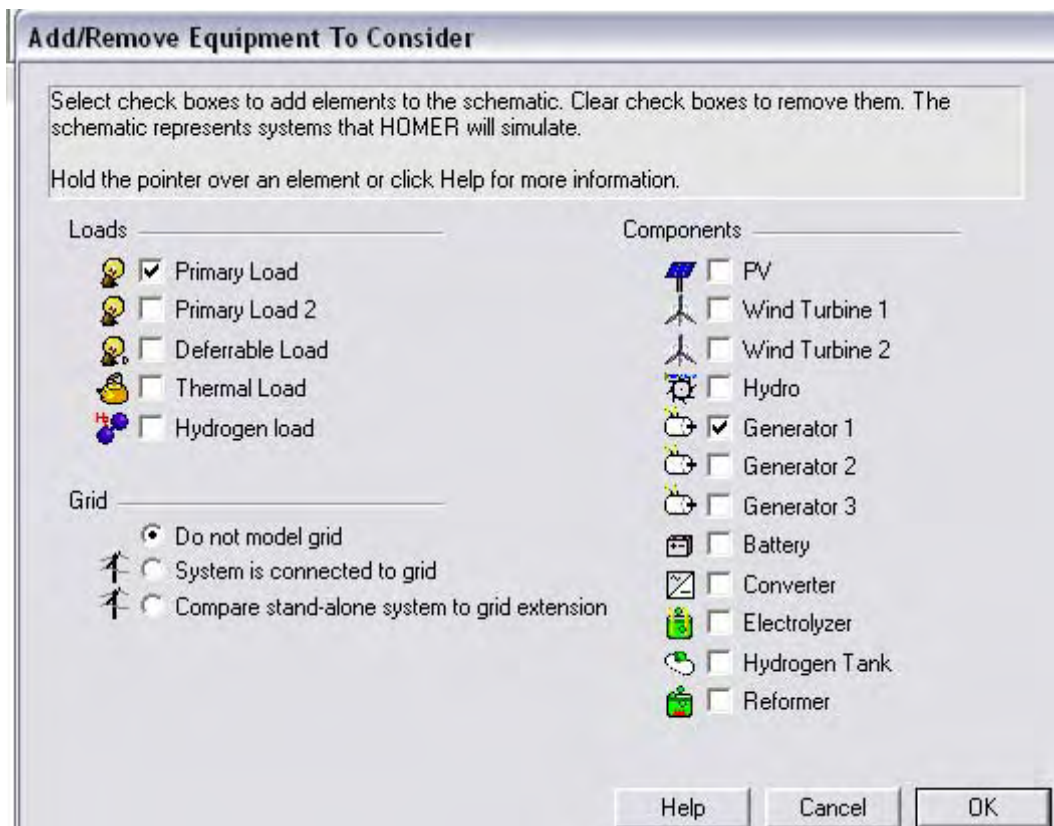

The selected components are now displayed in the left pane as 'Equipment to consider'. The next step is to specify the equipment details.

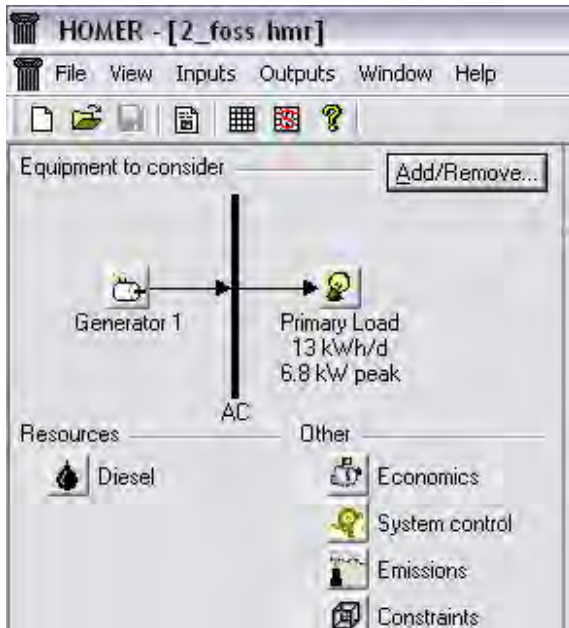

Clicking on the 'Generator' icon leads to the generator specification dialogue. Under the 'Cost' section, generator costs for Rotuma are specified. Cost data for Rotuma are given in Section 7.5. Costs for diesel generators are listed in Table 7.14, p. 199 and are directly entered in the table below. As specified in the Section 7.5.2, the generator lifetime is set to 50,000 operating hours, and the minimum load ration is entered as 20%. Under 'Sizes to consider', a number of generator sizes under consideration can be entered. The Home optimization will calculate the least cost diesel generator size that is able to satisfy the specified system loads.

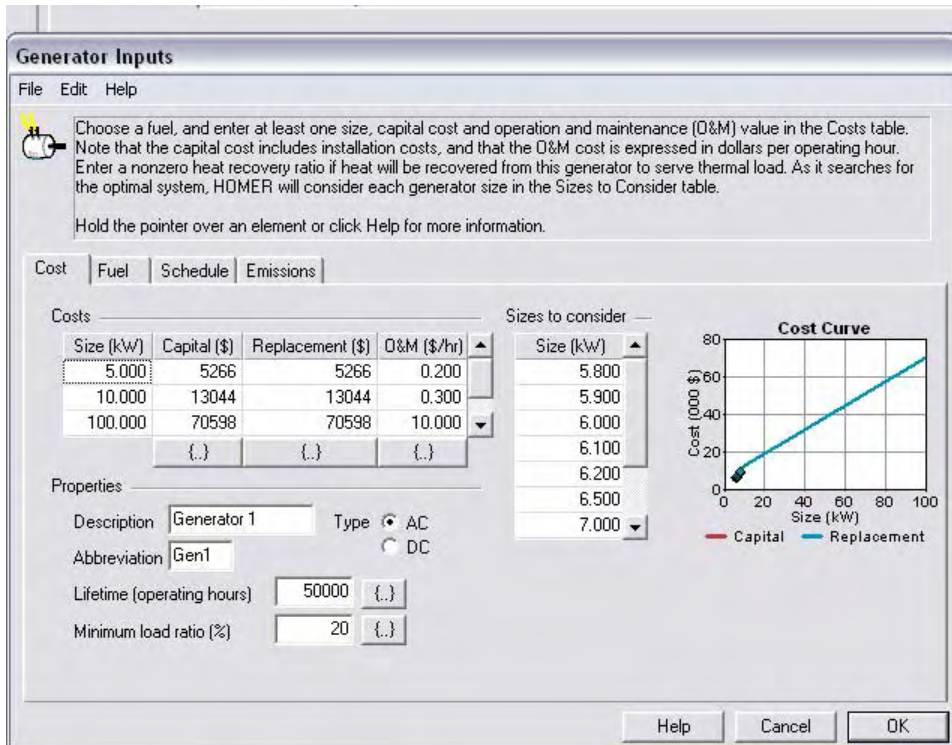

Clicking on the fuel pane enables us to enter values for the fuel type, in this case Diesel. Also entered are interception coefficient and slope of the generator efficiency curve, these values are also specified in Section 7.5.2. Properties of diesel fuel are predefined in Homer and do not need to be changed. The generator schedule pane is left at its default settings, the generator being in 'forced on' mode. Emissions are ignored since not studied in this context.

The generator is now fully specified, and a range of generator sizes is provided to Homer for consideration.

The next step is to define the system load. This is initiated by clicking on the load icon in the basic system diagram, leading to the dialogue in the picture below. The hourly loadcurve for this example system is given in Table 7.2, p.183. In this case, no distinction is made between weekdays and weekends.

Hourly and daily noise values, as specified in Table 7.11, are entered as 'Day to day variation' and 'time step to time step variation', in this case to 15%, each. The system load is this fully specified and the dialogue exited.

### Primary Load Inputs

File Edit Help

Choose a load type (AC or DC), enter 24 hourly values in the load table, and enter a scaled annual average. Each of the 24 values in the load table is the average electric demand for a single hour of the day. HOMER replicates this profile throughout the year unless you define different load profiles for different months or day types. For calculations, HOMER uses scaled data: baseline data scaled up or down to the scaled annual average value.

Hold the pointer over an element or click Help for more information.

Label: **Primary Load**    Load type:  AC  DC    Data source:  Enter daily profile(s)  Import time series data file    Import File...

Baseline data  
 Month: **January**    Day type: **Weekday**

Hour	Load (kW)
00:00 - 01:00	0.000
01:00 - 02:00	0.000
02:00 - 03:00	0.000
03:00 - 04:00	0.000
04:00 - 05:00	0.000
05:00 - 06:00	0.000
06:00 - 07:00	0.000
07:00 - 08:00	0.000
08:00 - 09:00	0.000
09:00 - 10:00	0.000
10:00 - 11:00	0.000
11:00 - 12:00	0.000

**Daily Profile**

**DMap**

**Seasonal Profile**

Random variability  
 Day-to-day:  %  
 Time-step-to-time-step:  %

Scaled annual average (kWh/d):  {..}

	Baseline	Scaled
Average (kWh/d)	13.1	13.1
Average (kW)	0.545	0.546
Peak (kW)	6.78	6.79
Load factor	0.0804	0.0804

Efficiency Inputs...  
 Plot... Export...  
 Help Cancel OK

The technical system is now fully specified.

Economic parameters are entered by clicking the 'Economics' button. For this example, as for all case studies, the project life is set to 25 years, and the real interest rate to 6%.

System control settings are default values, as shown in the Figure below.

### System Control Inputs

File Edit Help

The system control inputs define how HOMER models the operation of the battery bank and generators. The dispatch strategy determines how the system charges the battery bank.

Hold the pointer over an element name or click Help for more information.

Simulation time step (minutes):  {..}

Dispatch strategy

- Load following
- Cycle charging     Apply setpoint SOC

Setpoint state of charge (%):  {..}

Generator control

- Allow systems with multiple generators
- Allow multiple generators to operate simultaneously
- Allow systems with generator capacity less than peak load

Help Cancel OK



System constraints and emissions are not relevant to this option. However, if hybrid systems were to be considered, the ‘minimum renewability fraction’ would be set to 50%.

Now all modeling parameters are specified, and the simulation is initiated by clicking on the ‘Calculate’ button. Homer now simulates life cycle costs for every possible system configuration within the specified range. The best case system configuration is shown in the main output window (see below).

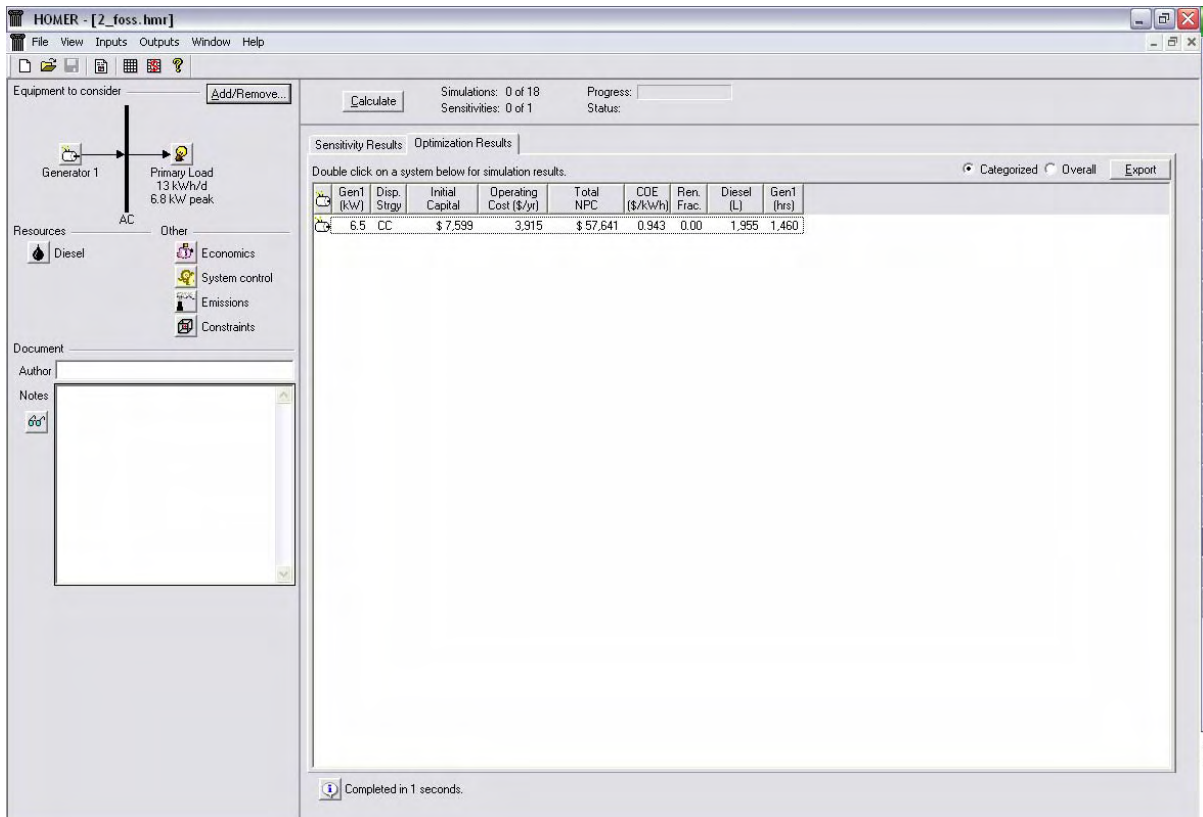

Double-clicking the system summary leads to a variety of simulation outputs and time series data.

The most significant output charts for all system options are collected in the appendix (Appendix C).

## **Appendix C – Homer Models and Outputs**

- I. Description of Homer – NREL Background Paper*
- II. Detailed description of Homer modeling process for one of the case studies – Level B – diesel supply*
- III. Homer details and modeling outputs for all 18 case studies***

# System Report – Level B – Diesel

## System architecture

Generator 1: 6.5 kW

## Cost summary

Total net present cost: 57,641 \$

Levelized cost of energy: 0.943 \$/kWh

## Cost breakdown

Component	Initial Capital	Annualized Capital	Annualized Replacement	Annual O&M	Annual Fuel	Total Annualized
	(\$)	(\$/yr)	(\$/yr)	(\$/yr)	(\$/yr)	(\$/yr)
Generator 1	7,599	594	-37	336	3,616	4,509
Totals	7,599	594	-37	336	3,616	4,509

## Annual electric energy production

Component	Production	Fraction
	(kWh/yr)	
Generator 1	4,782	100%
Total	4,782	100%

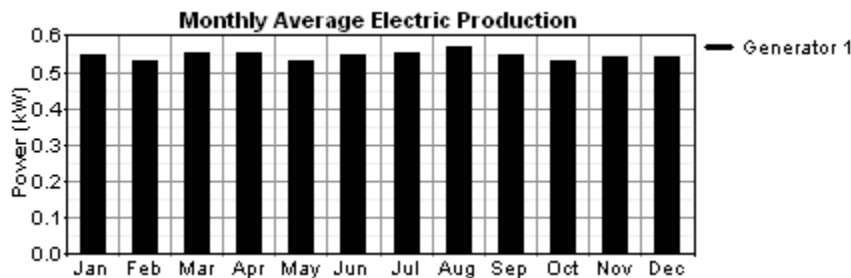

# Annual electric energy consumption

Load	Consumption	Fraction
	(kWh/yr)	
AC primary load	4,781	100%
Total	4,781	100%

Variable	Value	Units
Renewable fraction:	0.000	
Excess electricity:	1	kWh/yr
Unmet load:	1	kWh/yr
Capacity shortage:	3	kWh/yr

## Generator 1

Variable	Value	Units
Hours of operation:	1,460	hr/yr
Number of starts:	365	starts/yr
Operational life:	34.2	yr
Average electrical output:	3.28	kW
Minimum electrical output:	0.00	kW
Maximum electrical output:	6.50	kW
Annual fuel consumption:	1,955	L/yr
Specific fuel consumption:	0.409	L/kWh
Average electrical efficiency:	24.9	%

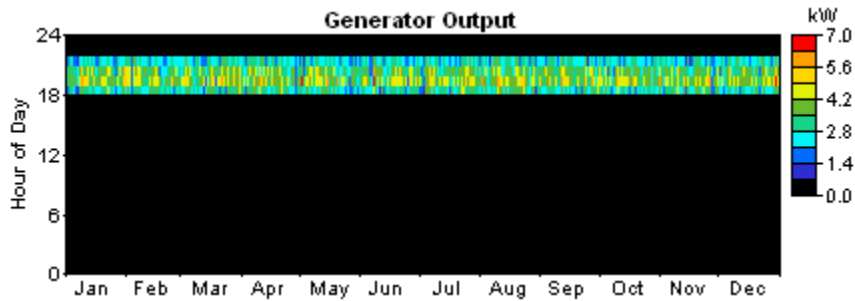

# System Report – Level B – Copra

## System architecture

Generator 1: 6.5 kW

## Cost summary

Total net present cost: 47,903 \$

Levelized cost of energy: 0.784 \$/kWh

## Cost breakdown

Component	Initial Capital	Annualized Capital	Annualized Replacement	Annual O&M	Annual Fuel	Total Annualized
	(\$)	(\$/yr)	(\$/yr)	(\$/yr)	(\$/yr)	(\$/yr)
Generator 1	8,360	654	-41	672	1,469	2,754
Other	3,100	243	0	751	0	994
Totals	11,460	896	-41	1,423	1,469	3,747

## Annual electric energy production

Component	Production	Fraction
	(kWh/yr)	
Generator 1	4,782	100%
Total	4,782	100%

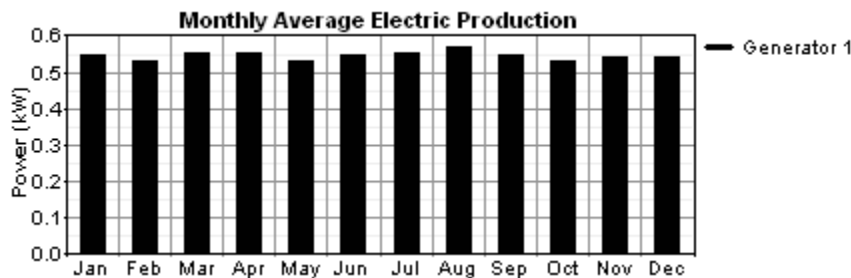

# Annual electric energy consumption

Load	Consumption	Fraction
	(kWh/yr)	
AC primary load	4,781	100%
Total	4,781	100%

Variable	Value	Units
Renewable fraction:	0.000	
Excess electricity:	1	kWh/yr
Unmet load:	1	kWh/yr
Capacity shortage:	3	kWh/yr

## Generator 1

Variable	Value	Units
Hours of operation:	1,460	hr/yr
Number of starts:	365	starts/yr
Operational life:	34.2	yr
Average electrical output:	3.28	kW
Minimum electrical output:	0.00	kW
Maximum electrical output:	6.50	kW
Annual fuel consumption:	2,193	L/yr
Specific fuel consumption:	0.459	L/kWh
Average electrical efficiency:	23.0	%

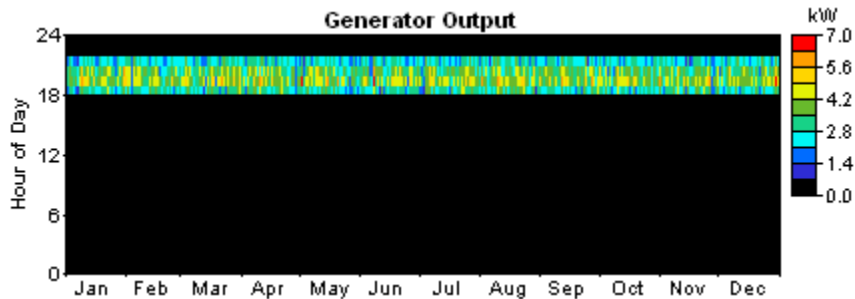

# System Report – Level B – Wind

## System architecture

Wind turbine: 9 Generic 1kW  
Battery: 100 ROT-Trojan T-105  
Inverter: 6.6 kW  
Rectifier: 6.6 kW

## Cost summary

Total net present cost: 177,482 \$  
Levelized cost of energy: 3.406 \$/kWh

## Cost breakdown

Component	Initial Capital	Annualized Capital	Annualized Replacement	Annual O&M	Annual Fuel	Total Annualized
	(\$)	(\$/yr)	(\$/yr)	(\$/yr)	(\$/yr)	(\$/yr)
Generic 1kW	79,380	6,210	-241	1,800	0	7,768
Battery	22,526	1,762	1,328	200	0	3,290
Converter	13,247	1,036	781	14	0	1,832
Other	3,100	243	0	751	0	994
Totals	118,253	9,251	1,868	2,765	0	13,884

## Annual electric energy production

Component	Production	Fraction
	(kWh/yr)	
Wind turbines	17,294	100%
Total	17,294	100%

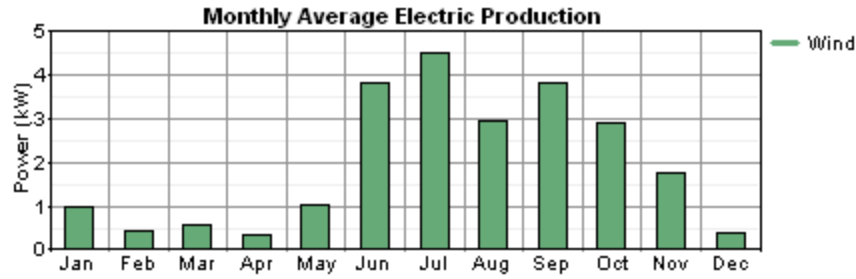

## Annual electric energy consumption

Load	Consumption	Fraction
	(kWh/yr)	
AC primary load	4,076	100%
Total	4,076	100%

Variable	Value	Units
Renewable fraction:	1.000	
Excess electricity:	12,427	kWh/yr
Unmet load:	705	kWh/yr
Capacity shortage:	813	kWh/yr

## DC Wind Turbine: Generic 1kW

Variable	Value	Units
Total capacity:	9.00	kW
Average output:	1.97	kW
Minimum output:	0.00	kW
Maximum output:	8.95	kW
Wind penetration:	362	%
Capacity factor:	21.9	%
Hours of operation:	7,390	hr/yr

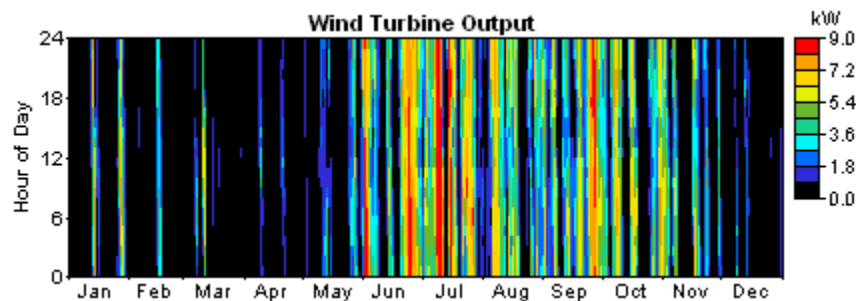



# Battery

Variable	Value	Units
Battery throughput	2,685	kWh/yr
Battery life	10.0	yr
Battery autonomy	173	hours

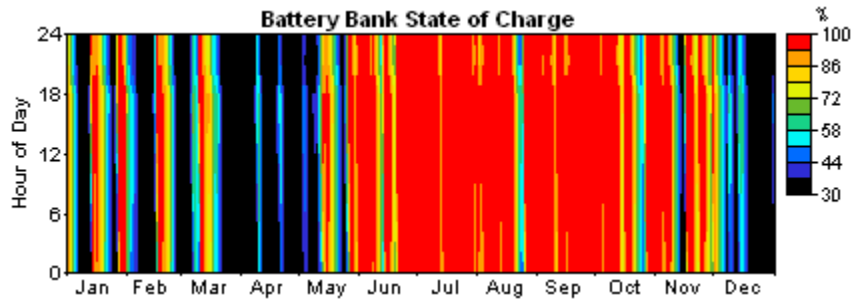
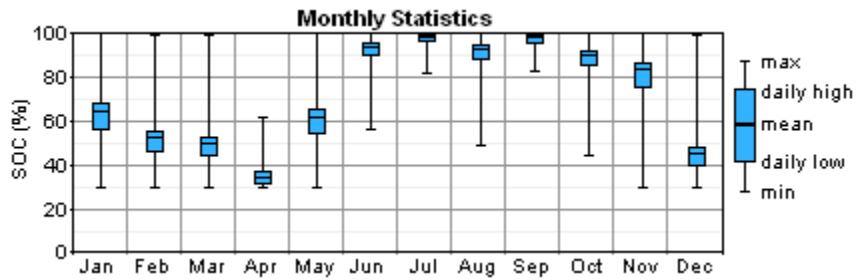
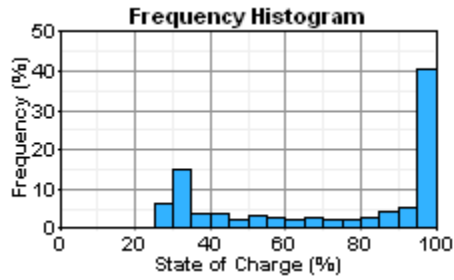

# System Report – Level B – Wind-Diesel

## System architecture

Wind turbine: 3 Generic 1kW  
Generator 1: 5 kW  
Battery: 10 Trojan T-105  
Inverter: 3.6 kW  
Rectifier: 3.6 kW  
Dispatch strategy: Load Following

## Cost summary

Total net present cost: 109,126 \$  
Levelized cost of energy: 1.785 \$/kWh

## Cost breakdown

Component	Initial Capital	Annualized Capital	Annualized Replacement	Annual O&M	Annual Fuel	Total Annualized
	(\$)	(\$/yr)	(\$/yr)	(\$/yr)	(\$/yr)	(\$/yr)
Generic 1kW	26,460	2,070	703	600	0	3,373
Generator 1	5,267	412	-45	212	2,390	2,969
Battery	3,520	275	247	20	0	543
Converter	11,978	937	706	9	0	1,653
Totals	47,225	3,694	1,611	841	2,390	8,537

## Annual electric energy production

Component	Production	Fraction
	(kWh/yr)	
Wind turbines	3,484	50%
Generator 1	3,473	50%
Total	6,957	100%

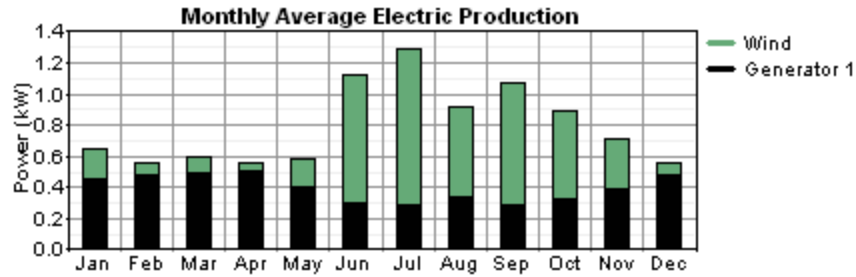

## Annual electric energy consumption

Load	Consumption	Fraction
	(kWh/yr)	
AC primary load	4,781	100%
Total	4,781	100%

Variable	Value	Units
Renewable fraction:	0.501	
Excess electricity:	1,886	kWh/yr
Unmet load:	0	kWh/yr
Capacity shortage:	3	kWh/yr

## DC Wind Turbine: Generic 1kW

Variable	Value	Units
Total capacity:	3.00	kW
Average output:	0.398	kW
Minimum output:	0.00	kW
Maximum output:	2.77	kW
Wind penetration:	72.9	%
Capacity factor:	13.3	%
Hours of operation:	6,908	hr/yr

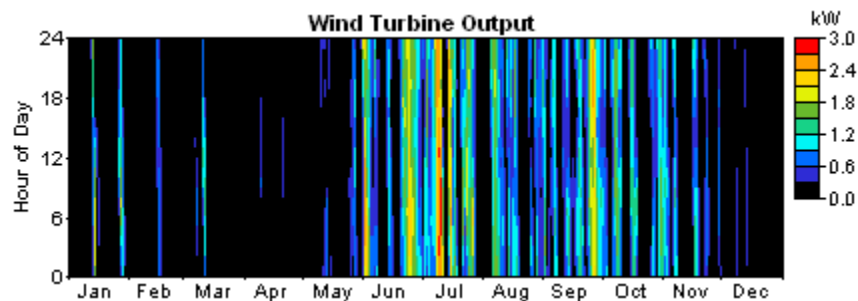

# Generator 1

Variable	Value	Units
Hours of operation:	1,059	hr/yr
Number of starts:	369	starts/yr
Operational life:	47.2	yr
Average electrical output:	3.28	kW
Minimum electrical output:	0.00	kW
Maximum electrical output:	5.00	kW
Annual fuel consumption:	1,292	L/yr
Specific fuel consumption:	0.372	L/kWh
Average electrical efficiency:	27.3	%

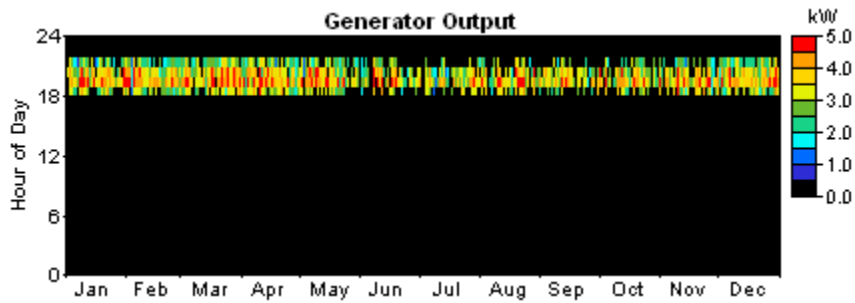

# Battery

Variable	Value	Units
Battery throughput	944	kWh/yr
Battery life	8.95	yr
Battery autonomy	17.3	hours

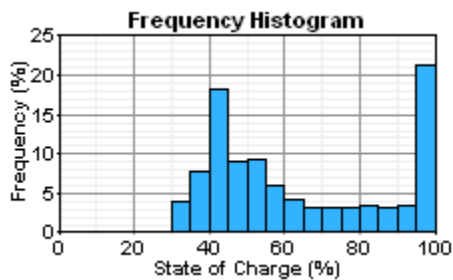

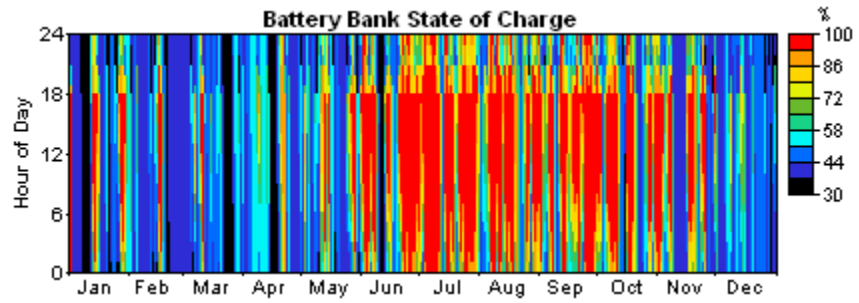
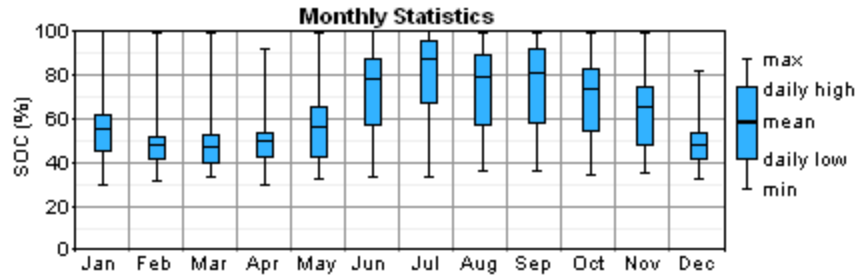

# System Report – Level B – Solar

## System architecture

PV Array: 4 kW  
 Battery: 63 Trojan T-105  
 Inverter: 6.6 kW  
 Rectifier: 6.6 kW

## Cost summary

Total net present cost: 201,297 \$  
 Levelized cost of energy: 3.294 \$/kWh

## Cost breakdown

Component	Initial Capital	Annualized Capital	Annualized Replacement	Annual O&M	Annual Fuel	Total Annualized
	(\$)	(\$/yr)	(\$/yr)	(\$/yr)	(\$/yr)	(\$/yr)
PV Array	67,093	5,248	1,782	2,667	0	9,698
Battery	22,176	1,735	1,411	126	0	3,271
Converter	20,144	1,576	1,188	14	0	2,778
Totals	109,414	8,559	4,381	2,807	0	15,747

## Annual electric energy production

Component	Production	Fraction
	(kWh/yr)	
PV array	8,545	100%
Total	8,545	100%

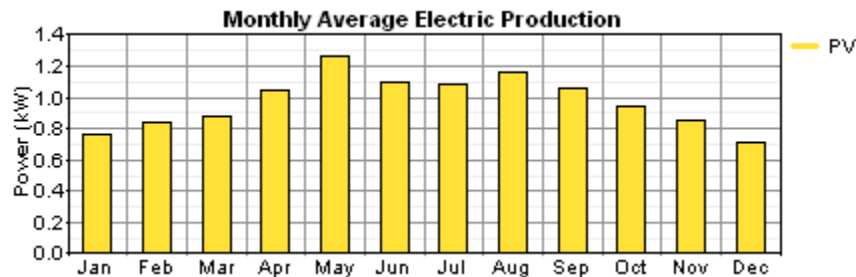

## Annual electric energy consumption

Load	Consumption	Fraction
	(kWh/yr)	
AC primary load	4,781	100%
Total	4,781	100%

Variable	Value	Units
Renewable fraction:	1.000	
Excess electricity:	1,745	kWh/yr
Unmet load:	0	kWh/yr
Capacity shortage:	3	kWh/yr

## PV

Variable	Value	Units
Average output:	23.4	kWh/d
Minimum output:	0.00	kW
Maximum output:	4.52	kW
Solar penetration:	179	%
Capacity factor:	24.4	%
Hours of operation:	4,386	hr/yr

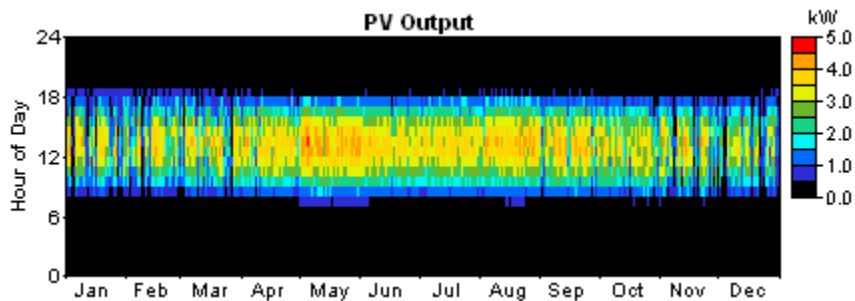

## Battery

Variable	Value	Units
Battery throughput	5,576	kWh/yr
Battery life	9.55	yr
Battery autonomy	109	hours

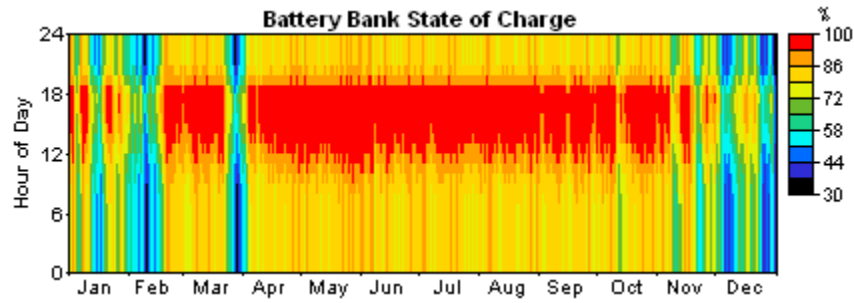
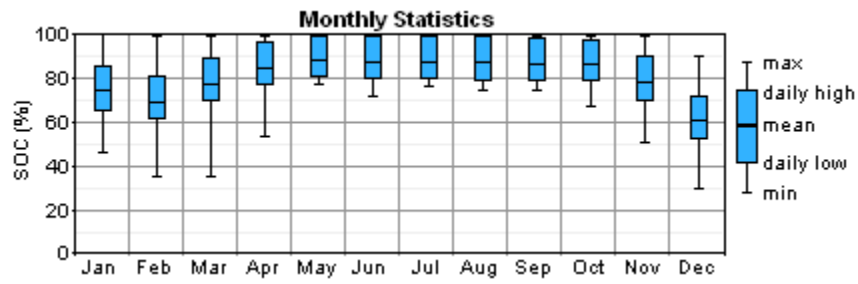
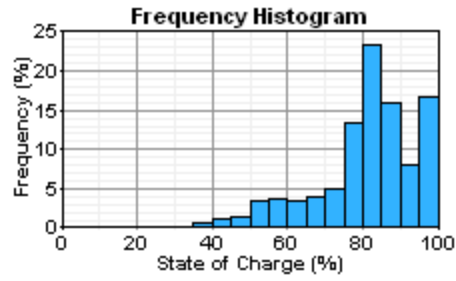



# System Report – Level B – Solar-Diesel

## System architecture

PV Array: 1.6 kW  
Generator 1: 4 kW  
Battery: 10 Trojan T-105  
Inverter: 3.3 kW  
Rectifier: 3.3 kW  
Dispatch strategy: Load Following

## Cost summary

Total net present cost: 117,632 \$  
Levelized cost of energy: 1.924 \$/kWh

## Cost breakdown

Component	Initial Capital	Annualized Capital	Annualized Replacement	Annual O&M	Annual Fuel	Total Annualized
	(\$)	(\$/yr)	(\$/yr)	(\$/yr)	(\$/yr)	(\$/yr)
PV Array	28,171	2,204	748	1,333	0	4,285
Generator 1	3,712	290	-36	171	2,096	2,521
Battery	3,520	275	560	20	0	856
Converter	11,161	873	658	9	0	1,540
Totals	46,563	3,643	1,931	1,533	2,096	9,202

## Annual electric energy production

Component	Production	Fraction
	(kWh/yr)	
PV array	3,418	51%
Generator 1	3,318	49%
Total	6,736	100%

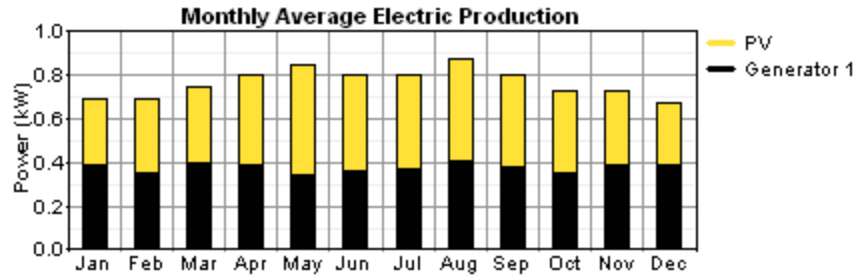

## Annual electric energy consumption

Load	Consumption	Fraction
	(kWh/yr)	
AC primary load	4,781	100%
Total	4,781	100%

Variable	Value	Units
Renewable fraction:	0.507	
Excess electricity:	1,328	kWh/yr
Unmet load:	0	kWh/yr
Capacity shortage:	1	kWh/yr

## PV

Variable	Value	Units
Average output:	9.36	kWh/d
Minimum output:	0.00	kW
Maximum output:	1.81	kW
Solar penetration:	71.5	%
Capacity factor:	24.4	%
Hours of operation:	4,386	hr/yr

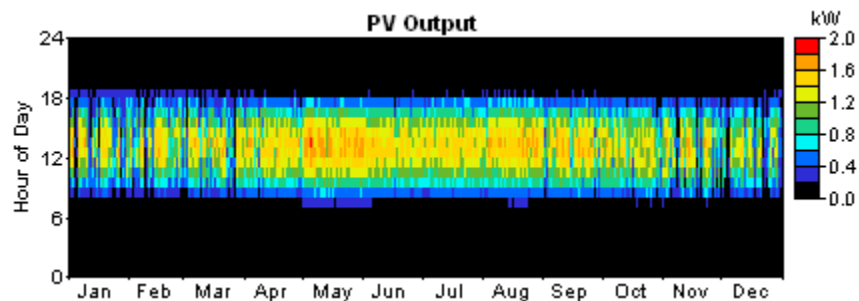

# Generator 1

Variable	Value	Units
Hours of operation:	948	hr/yr
Number of starts:	404	starts/yr
Operational life:	52.7	yr
Average electrical output:	3.50	kW
Minimum electrical output:	0.00	kW
Maximum electrical output:	4.00	kW
Annual fuel consumption:	1,133	L/yr
Specific fuel consumption:	0.341	L/kWh
Average electrical efficiency:	29.8	%

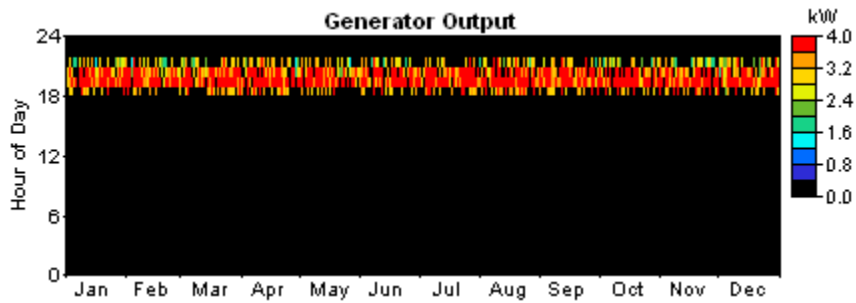

# Battery

Variable	Value	Units
Battery throughput	1,690	kWh/yr
Battery life	5.00	yr
Battery autonomy	17.3	hours

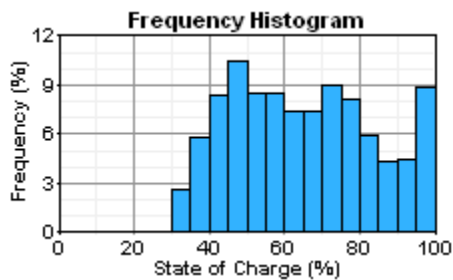

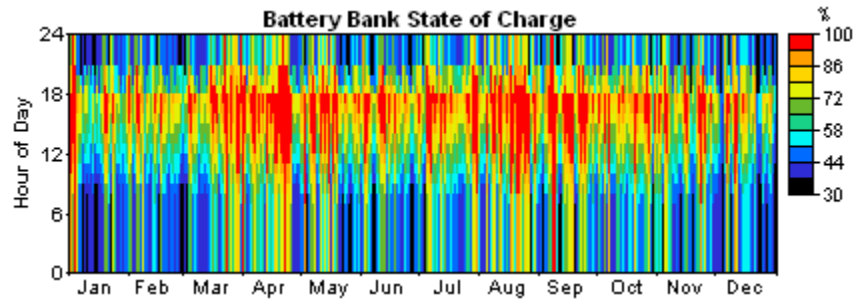
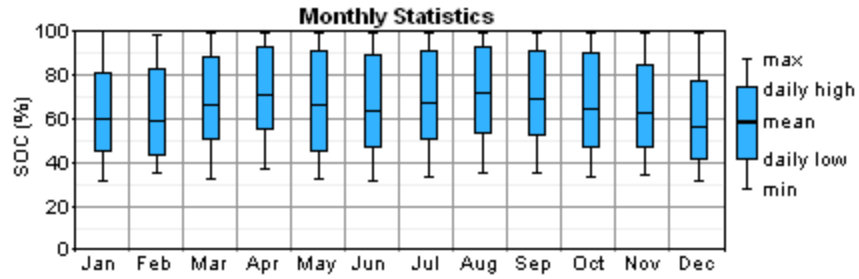

# System Report – Level C – Diesel

## System architecture

Generator 1: 234 kW

Generator 2: 139 kW

## Cost summary

Total net present cost: 8,385,090 \$

Levelized cost of energy: 1.063 \$/kWh

## Cost breakdown

Component	Initial Capital	Annualized Capital	Annualized Replacement	Annual O&M	Annual Fuel	Total Annualized
	(\$)	(\$/yr)	(\$/yr)	(\$/yr)	(\$/yr)	(\$/yr)
Generator 1	114,370	8,947	800	29,430	268,878	308,055
Generator 2	83,338	6,519	1,056	27,985	150,374	185,934
Other	1,878,500	146,949	0	15,000	0	161,949
Totals	2,076,207	162,415	1,856	72,415	419,252	655,938

## Annual electric energy production

Component	Production	Fraction
	(kWh/yr)	
Generator 1	407,561	66%
Generator 2	209,662	34%
Total	617,223	100%

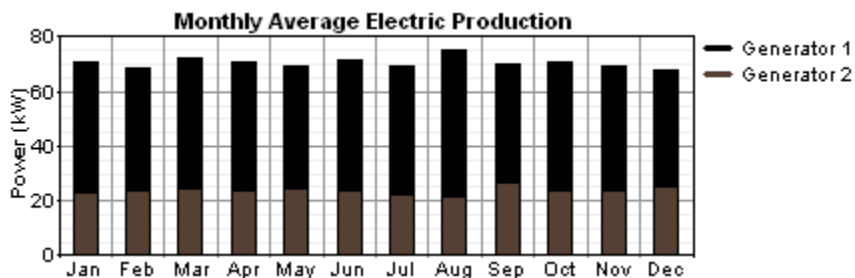

# Annual electric energy consumption

Load	Consumption	Fraction
	(kWh/yr)	
AC primary load	617,215	100%
Total	617,215	100%

Variable	Value	Units
Renewable fraction:	0.000	
Excess electricity:	9	kWh/yr
Unmet load:	0	kWh/yr
Capacity shortage:	19	kWh/yr

## Generator 1

Variable	Value	Units
Hours of operation:	2,321	hr/yr
Number of starts:	641	starts/yr
Operational life:	21.5	yr
Average electrical output:	176	kW
Minimum electrical output:	0.00	kW
Maximum electrical output:	234	kW
Annual fuel consumption:	145,339	L/yr
Specific fuel consumption:	0.357	L/kWh
Average electrical efficiency:	28.5	%

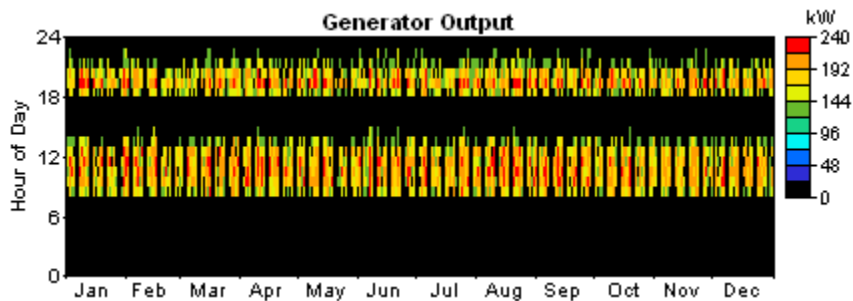

## Generator 2

Variable	Value	Units
Hours of operation:	2,596	hr/yr
Number of starts:	1,196	starts/yr
Operational life:	19.3	yr
Average electrical output:	80.8	kW
Minimum electrical output:	0.00	kW
Maximum electrical output:	126	kW
Annual fuel consumption:	81,283	L/yr
Specific fuel consumption:	0.388	L/kWh
Average electrical efficiency:	26.2	%

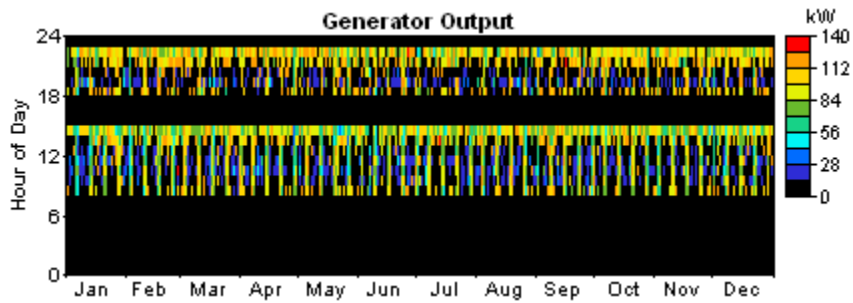

# System Report – Level C – Copra

## System architecture

Generator 1: 140 kW

Generator 2: 255 kW

## Cost summary

Total net present cost: 7,051,504 \$

Levelized cost of energy: 0.894 \$/kWh

## Cost breakdown

Component	Initial Capital	Annualized Capital	Annualized Replacement	Annual O&M	Annual Fuel	Total Annualized
	(\$)	(\$/yr)	(\$/yr)	(\$/yr)	(\$/yr)	(\$/yr)
Generator 1	92,030	7,199	735	51,149	58,983	118,066
Generator 2	133,352	10,432	862	60,155	98,090	169,539
Other	2,227,000	174,211	0	89,800	0	264,011
Totals	2,452,382	191,842	1,597	201,104	157,074	551,616

## Annual electric energy production

Component	Production	Fraction
	(kWh/yr)	
Generator 1	235,851	38%
Generator 2	381,374	62%
Total	617,225	100%

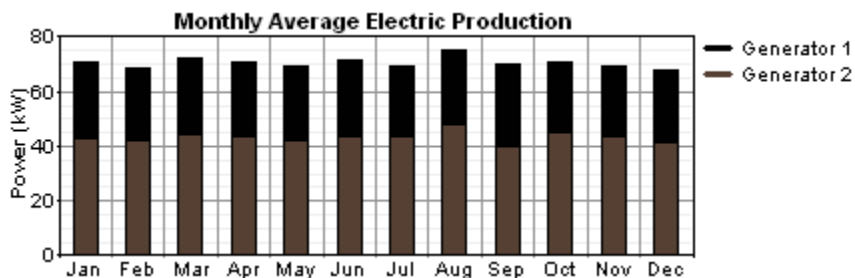



# Annual electric energy consumption

Load	Consumption	Fraction
	(kWh/yr)	
AC primary load	617,215	100%
Total	617,215	100%

Variable	Value	Units
Renewable fraction:	0.000	
Excess electricity:	9	kWh/yr
Unmet load:	0	kWh/yr
Capacity shortage:	0	kWh/yr

## Generator 1

Variable	Value	Units
Hours of operation:	2,368	hr/yr
Number of starts:	1,099	starts/yr
Operational life:	21.1	yr
Average electrical output:	99.6	kW
Minimum electrical output:	0.00	kW
Maximum electrical output:	140	kW
Annual fuel consumption:	88,035	L/yr
Specific fuel consumption:	0.373	L/kWh
Average electrical efficiency:	28.2	%

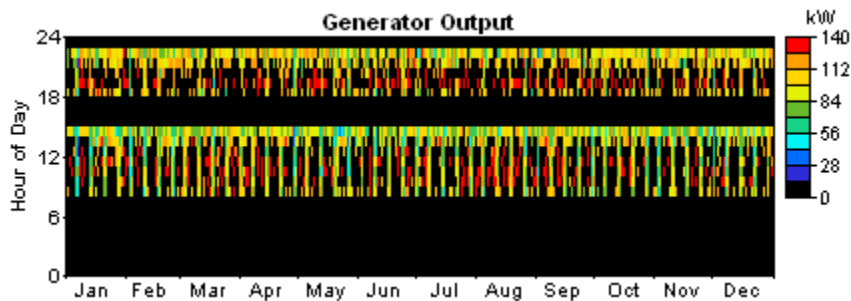

## Generator 2

Variable	Value	Units
Hours of operation:	2,296	hr/yr
Number of starts:	639	starts/yr
Operational life:	21.8	yr
Average electrical output:	166	kW
Minimum electrical output:	0.00	kW
Maximum electrical output:	232	kW
Annual fuel consumption:	146,404	L/yr
Specific fuel consumption:	0.384	L/kWh
Average electrical efficiency:	27.4	%

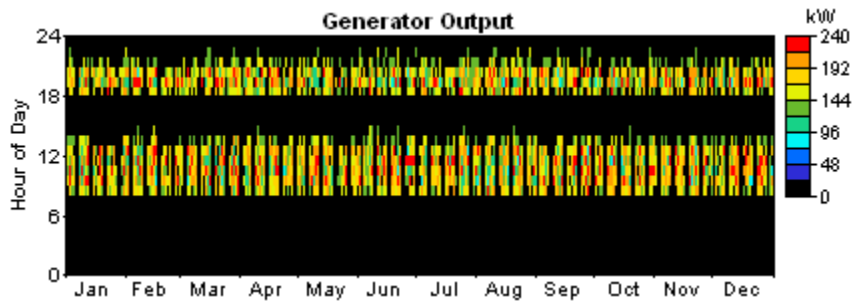

# System Report – Level C – Wind

## System architecture

Wind turbine: 1,500 Generic 1kW AC  
 Battery: 25,000 ROT-Trojan T-105  
 Inverter: 300 kW  
 Rectifier: 300 kW

## Cost summary

Total net present cost: 28,108,476 \$  
 Levelized cost of energy: 3.563 \$/kWh

## Cost breakdown

Component	Initial Capital	Annualized Capital	Annualized Replacement	Annual O&M	Annual Fuel	Total Annualized
	(\$)	(\$/yr)	(\$/yr)	(\$/yr)	(\$/yr)	(\$/yr)
Generic 1kW AC	5,380,500	420,899	57,687	150,000	0	628,585
Battery	9,175,000	717,730	540,953	50,000	0	1,308,684
Converter	724,111	56,645	42,693	278	0	99,616
Other	1,878,500	146,949	0	15,000	0	161,949
Totals	17,158,112	1,342,223	641,333	215,278	0	2,198,834

## Annual electric energy production

Component	Production	Fraction
	(kWh/yr)	
Wind turbines	3,777,891	100%
Total	3,777,891	100%

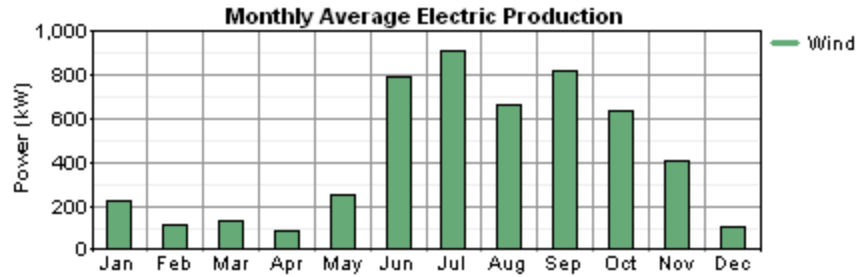

## Annual electric energy consumption

Load	Consumption	Fraction
	(kWh/yr)	
AC primary load	617,173	100%
Total	617,173	100%

Variable	Value	Units
Renewable fraction:	1.000	
Excess electricity:	3,057,293	kWh/yr
Unmet load:	42	kWh/yr
Capacity shortage:	279	kWh/yr

## AC Wind Turbine: Generic 1kW AC

Variable	Value	Units
Total capacity:	1,500	kW
Average output:	431	kW
Minimum output:	0.00	kW
Maximum output:	1,497	kW
Wind penetration:	612	%
Capacity factor:	28.8	%
Hours of operation:	7,675	hr/yr

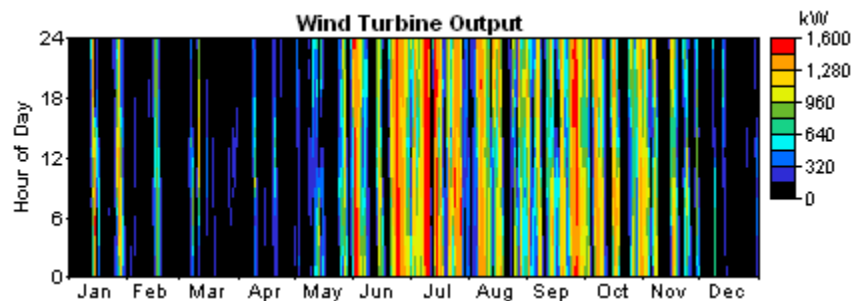

# Battery

Variable	Value	Units
Battery throughput	253,443	kWh/yr
Battery life	10.0	yr
Battery autonomy	335	hours

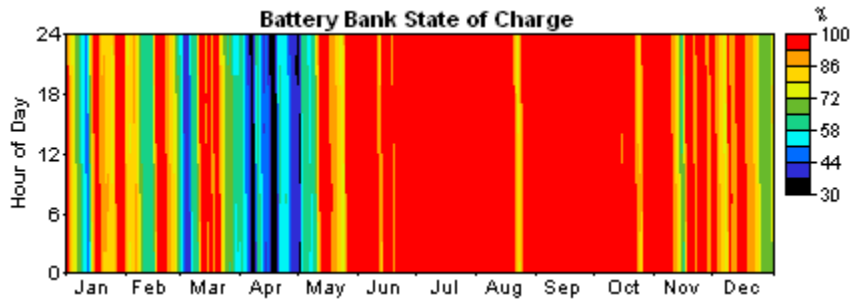
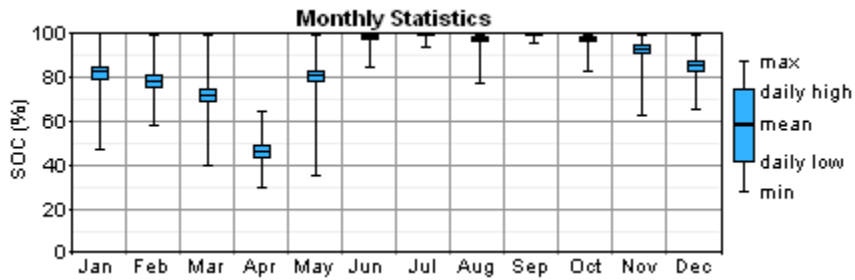
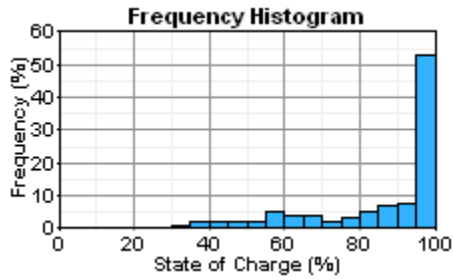

# System Report – Level C – Wind-Diesel

## System architecture

Wind turbine: 200 Generic 1kW AC  
Generator 1: 180 kW  
Generator 2: 85 kW  
Battery: 200 ROT-Trojan T-105  
Inverter: 100 kW  
Rectifier: 100 kW  
Dispatch strategy: Load Following

## Cost summary

Total net present cost: 7,588,317 \$  
Levelized cost of energy: 0.962 \$/kWh

## Cost breakdown

Component	Initial Capital	Annualized Capital	Annualized Replacement	Annual O&M	Annual Fuel	Total Annualized
	(\$)	(\$/yr)	(\$/yr)	(\$/yr)	(\$/yr)	(\$/yr)
Generic 1kW AC	717,400	56,120	7,692	20,000	0	83,811
Generator 1	96,730	7,567	-211	20,428	168,118	195,902
Generator 2	61,006	4,772	31	16,959	83,239	105,002
Battery	73,400	5,742	7,093	400	0	13,235
Converter	245,000	19,166	14,445	100	0	33,711
Other	1,878,500	146,949	0	15,000	0	161,949
Totals	3,072,036	240,315	29,050	72,887	251,356	593,609

## Annual electric energy production

Component	Production	Fraction
	(kWh/yr)	
Wind turbines	503,723	57%
Generator 1	262,066	29%
Generator 2	124,949	14%
Total	890,738	100%

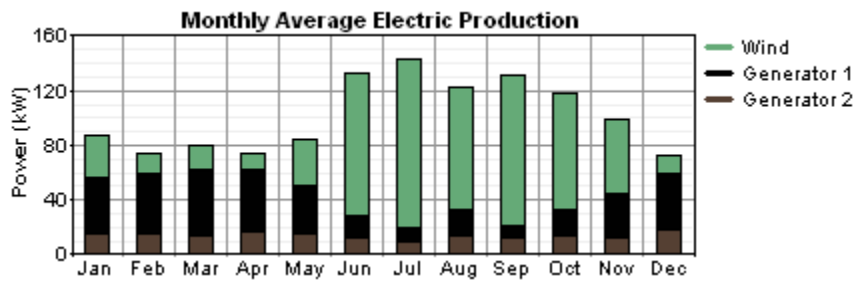

## Annual electric energy consumption

Load	Consumption	Fraction
	(kWh/yr)	
AC primary load	617,156	100%
Total	617,156	100%

Variable	Value	Units
Renewable fraction:	0.566	
Excess electricity:	263,379	kWh/yr
Unmet load:	59	kWh/yr
Capacity shortage:	568	kWh/yr

## AC Wind Turbine: Generic 1kW AC

Variable	Value	Units
Total capacity:	200	kW
Average output:	57.5	kW
Minimum output:	0.00	kW
Maximum output:	200	kW
Wind penetration:	81.6	%
Capacity factor:	28.8	%
Hours of operation:	7,675	hr/yr

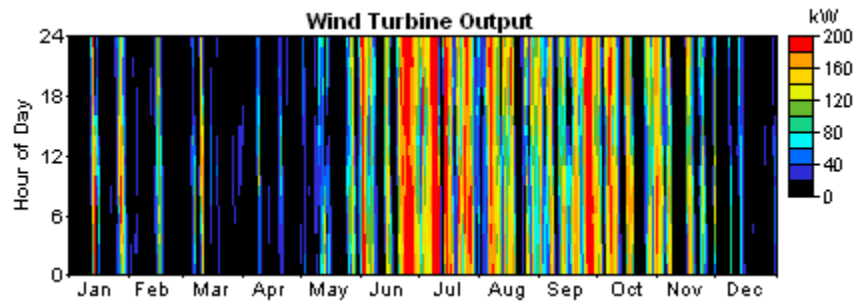

## Generator 1



Variable	Value	Units
Hours of operation:	1,761	hr/yr
Number of starts:	549	starts/yr
Operational life:	28.4	yr
Average electrical output:	149	kW
Minimum electrical output:	0.00	kW
Maximum electrical output:	180	kW
Annual fuel consumption:	90,874	L/yr
Specific fuel consumption:	0.347	L/kWh
Average electrical efficiency:	29.3	%

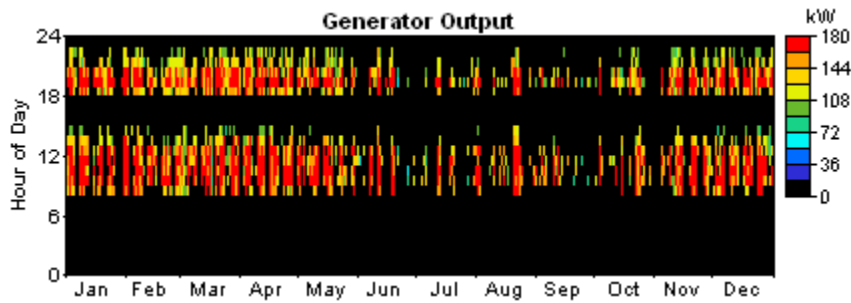

## Generator 2

Variable	Value	Units
Hours of operation:	2,023	hr/yr
Number of starts:	1,038	starts/yr
Operational life:	24.7	yr
Average electrical output:	61.8	kW
Minimum electrical output:	0.00	kW
Maximum electrical output:	85.0	kW
Annual fuel consumption:	44,994	L/yr
Specific fuel consumption:	0.360	L/kWh
Average electrical efficiency:	28.2	%

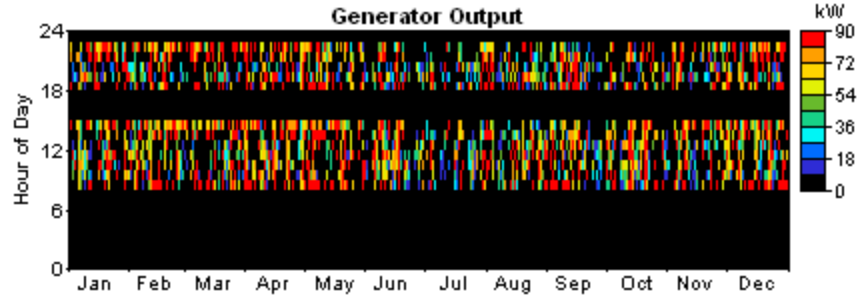

## Battery

Variable	Value	Units
Battery throughput	23,275	kWh/yr
Battery life	7.26	yr
Battery autonomy	2.68	hours

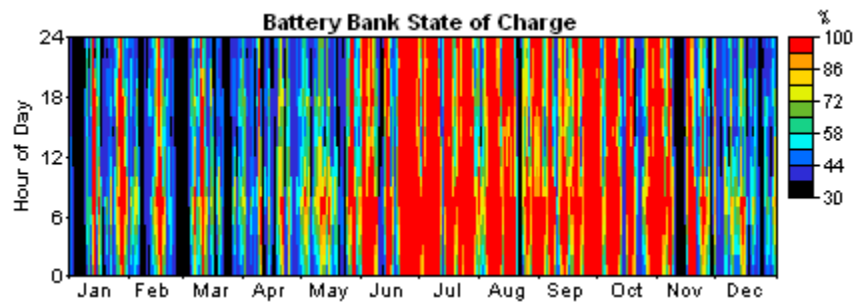
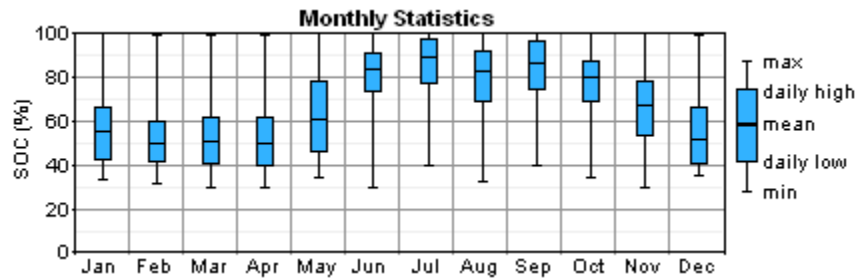
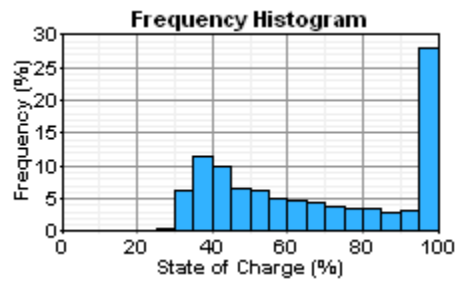

# System Report – Level C – Solar

## System architecture

PV Array: 560 kW  
Battery: 7,600 ROT-Trojan T-105  
Inverter: 360 kW  
Rectifier: 360 kW

## Cost summary

Total net present cost: 22,077,796 \$  
Levelized cost of energy: 2.800 \$/kWh

## Cost breakdown

Component	Initial Capital	Annualized Capital	Annualized Replacement	Annual O&M	Annual Fuel	Total Annualized
	(\$)	(\$/yr)	(\$/yr)	(\$/yr)	(\$/yr)	(\$/yr)
PV Array	7,959,734	622,664	211,456	213,778	0	1,047,898
Battery	2,789,200	218,190	164,450	15,200	0	397,840
Converter	867,844	67,889	51,168	331	0	119,387
Other	1,878,500	146,949	0	15,000	0	161,949
Totals	13,495,278	1,055,691	427,073	244,309	0	1,727,074

## Annual electric energy production

Component	Production	Fraction
	(kWh/yr)	
PV array	869,080	100%
Total	869,080	100%

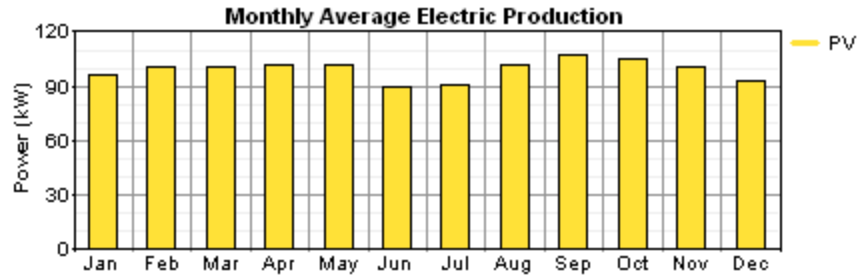

## Annual electric energy consumption

Load	Consumption	Fraction
	(kWh/yr)	
AC primary load	616,728	100%
Total	616,728	100%

Variable	Value	Units
Renewable fraction:	1.000	
Excess electricity:	127,032	kWh/yr
Unmet load:	487	kWh/yr
Capacity shortage:	614	kWh/yr

## PV

Variable	Value	Units
Average output:	2,381	kWh/d
Minimum output:	0.00	kW
Maximum output:	593	kW
Solar penetration:	141	%
Capacity factor:	17.7	%
Hours of operation:	4,386	hr/yr

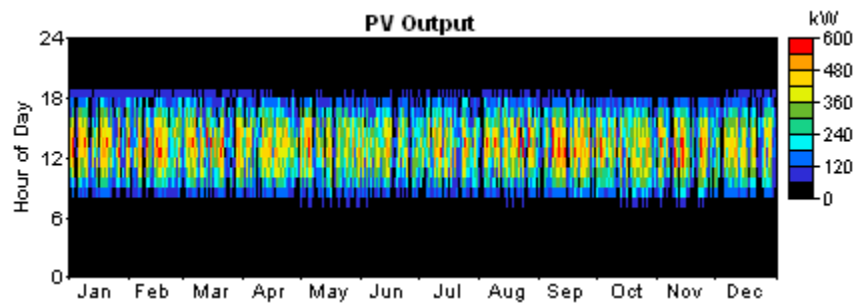

# Battery

Variable	Value	Units
Battery throughput	365,472	kWh/yr
Battery life	10.0	yr
Battery autonomy	102	hours

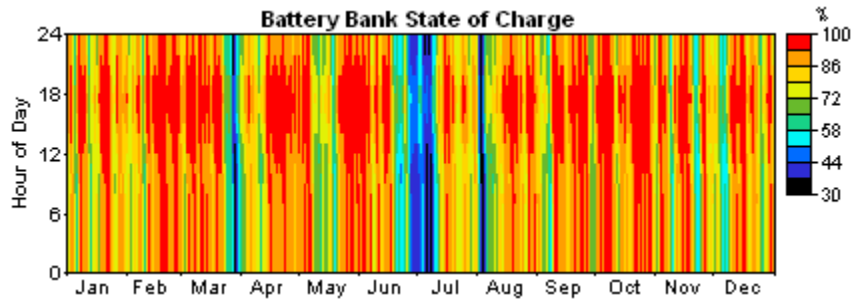
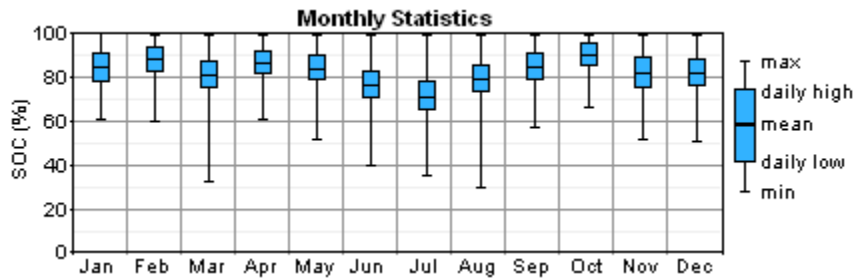
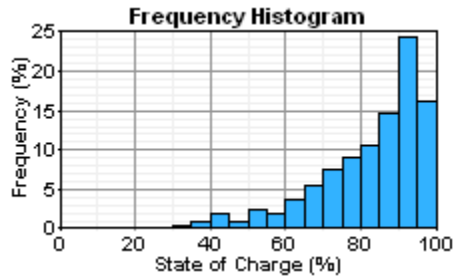

# System Report – Level C – Solar-Diesel

## System architecture

PV Array:	250 kW
Generator 1:	170 kW
Generator 2:	90 kW
Battery:	200 ROT-Trojan T-105
Inverter:	140 kW
Rectifier:	140 kW
Dispatch strategy:	Load Following

## Cost summary

Total net present cost:	12,784,249 \$
Levelized cost of energy:	1.621 \$/kWh

## Cost breakdown

Component	Initial Capital	Annualized Capital	Annualized Replacement	Annual O&M	Annual Fuel	Total Annualized
	(\$)	(\$/yr)	(\$/yr)	(\$/yr)	(\$/yr)	(\$/yr)
PV Array	3,566,000	278,956	94,733	96,667	0	470,356
Generator 1	93,464	7,311	-224	19,802	156,468	183,357
Generator 2	64,203	5,022	383	20,280	96,444	122,130
Battery	73,400	5,742	9,244	400	0	15,385
Converter	340,822	26,661	20,095	136	0	46,892
Other	1,878,500	146,949	0	15,000	0	161,949
Totals	6,016,389	470,642	124,231	152,284	252,912	1,000,070

## Annual electric energy production

Component	Production	Fraction
	(kWh/yr)	
PV array	387,982	50%
Generator 1	243,815	31%
Generator 2	143,067	18%
Total	774,864	100%

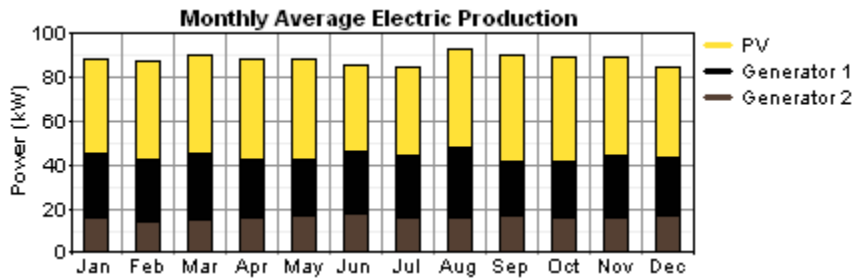

## Annual electric energy consumption

Load	Consumption	Fraction
	(kWh/yr)	
AC primary load	617,074	100%
Total	617,074	100%

Variable	Value	Units
Renewable fraction:	0.501	
Excess electricity:	127,792	kWh/yr
Unmet load:	141	kWh/yr
Capacity shortage:	528	kWh/yr

**PV**

Variable	Value	Units
Average output:	1,063	kWh/d
Minimum output:	0.00	kW
Maximum output:	265	kW
Solar penetration:	62.9	%
Capacity factor:	17.7	%
Hours of operation:	4,386	hr/yr

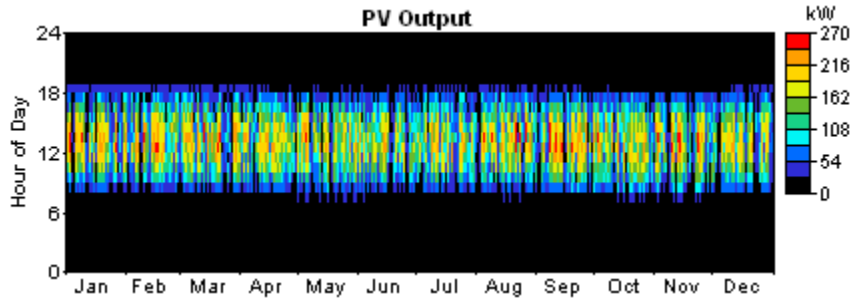

## Generator 1

Variable	Value	Units
Hours of operation:	1,737	hr/yr
Number of starts:	662	starts/yr
Operational life:	28.8	yr
Average electrical output:	140	kW
Minimum electrical output:	0.00	kW
Maximum electrical output:	170	kW
Annual fuel consumption:	84,577	L/yr
Specific fuel consumption:	0.347	L/kWh
Average electrical efficiency:	29.3	%

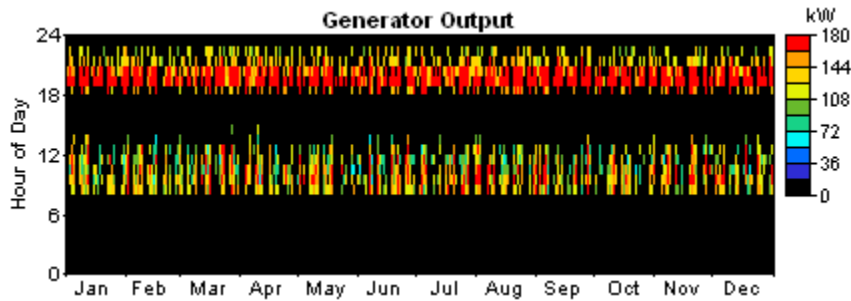

## Generator 2



Variable	Value	Units
Hours of operation:	2,273	hr/yr
Number of starts:	1,161	starts/yr
Operational life:	22.0	yr
Average electrical output:	62.9	kW
Minimum electrical output:	0.00	kW
Maximum electrical output:	90.0	kW
Annual fuel consumption:	52,132	L/yr
Specific fuel consumption:	0.364	L/kWh
Average electrical efficiency:	27.9	%

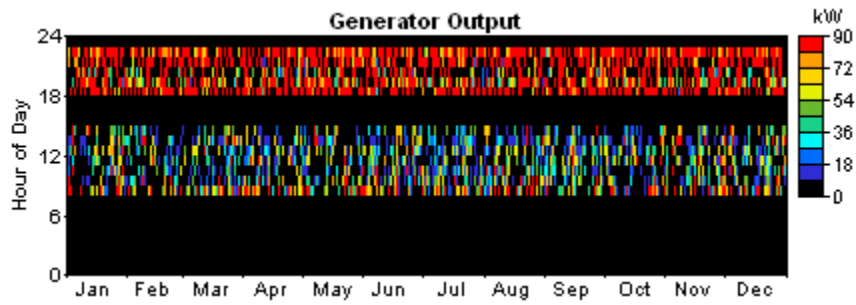

## Battery

Variable	Value	Units
Battery throughput	28,226	kWh/yr
Battery life	5.99	yr
Battery autonomy	2.68	hours

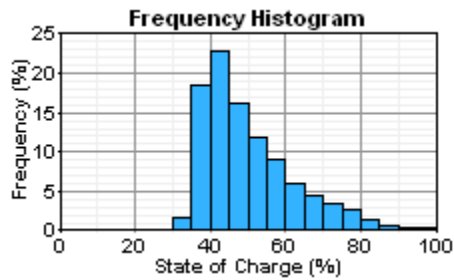

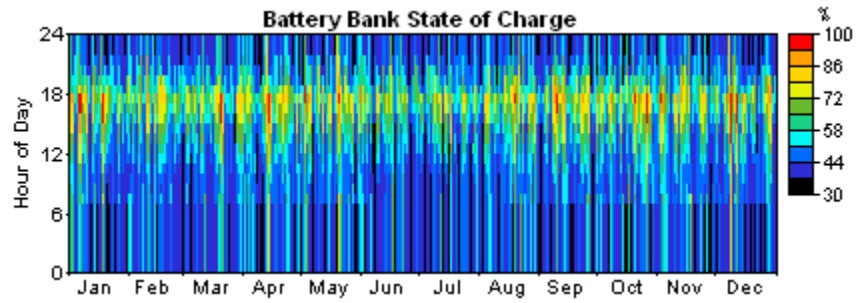
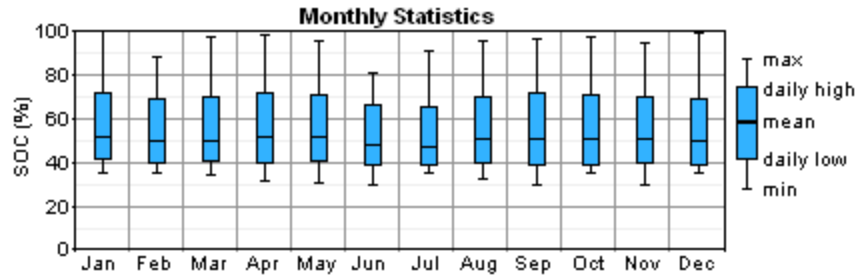

# System Report – Level D – Diesel

## System architecture

Generator 1: 540 kW

Generator 2: 280 kW

## Cost summary

Total net present cost: 32,435,054 \$

Levelized cost of energy: 0.798 \$/kWh

## Cost breakdown

Component	Initial Capital	Annualized Capital	Annualized Replacement	Annual O&M	Annual Fuel	Total Annualized
	(\$)	(\$/yr)	(\$/yr)	(\$/yr)	(\$/yr)	(\$/yr)
Generator 1	214,326	16,766	16,239	110,713	1,619,774	1,763,492
Generator 2	129,396	10,122	7,492	67,279	526,953	611,847
Other	1,878,500	146,949	0	15,000	0	161,949
Totals	2,222,222	173,837	23,732	192,992	2,146,727	2,537,288

## Annual electric energy production

Component	Production	Fraction
	(kWh/yr)	
Generator 1	2,484,618	78%
Generator 2	696,091	22%
Total	3,180,709	100%

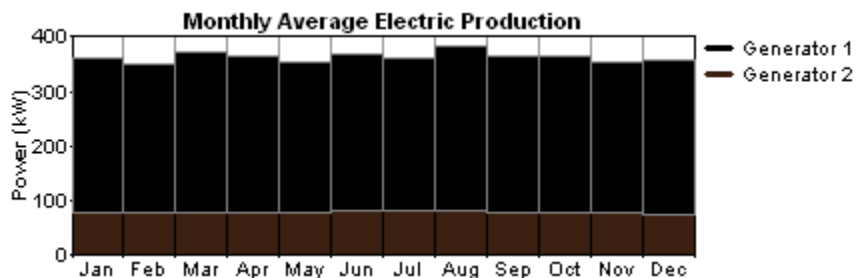

# Annual electric energy consumption

Load	Consumption	Fraction
	(kWh/yr)	
AC primary load	3,180,664	100%
Total	3,180,664	100%

Variable	Value	Units
Renewable fraction:	0.000	
Excess electricity:	40	kWh/yr
Unmet load:	309	kWh/yr
Capacity shortage:	3,074	kWh/yr

## Generator 1

Variable	Value	Units
Hours of operation:	5,889	hr/yr
Number of starts:	507	starts/yr
Operational life:	8.49	yr
Average electrical output:	422	kW
Minimum electrical output:	255	kW
Maximum electrical output:	540	kW
Annual fuel usage:	875,553	L/yr
Specific fuel usage:	0.352	L/kWh
Average electrical efficiency:	28.8	%

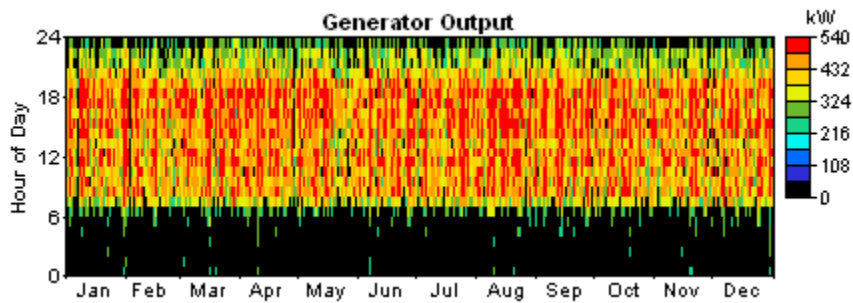

## Generator 2

Variable	Value	Units
Hours of operation:	4,947	hr/yr
Number of starts:	1,258	starts/yr
Operational life:	10.1	yr
Average electrical output:	141	kW
Minimum electrical output:	56.0	kW
Maximum electrical output:	280	kW
Annual fuel usage:	284,839	L/yr
Specific fuel usage:	0.409	L/kWh
Average electrical efficiency:	24.8	%

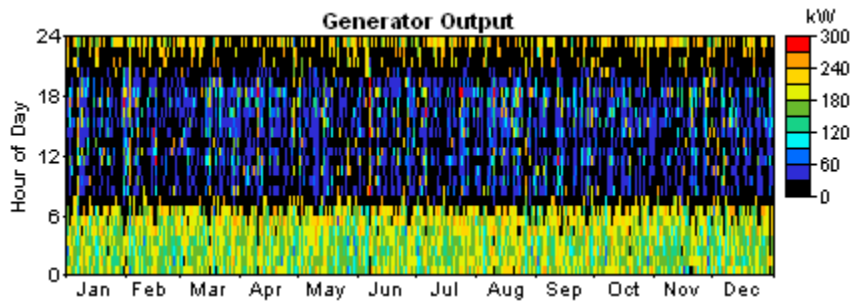

# System Report – Level D – Coconut Oil

## System architecture

Generator 1: 560 kW

Generator 2: 260 kW

## Cost summary

Total net present cost: 19,860,700 \$

Levelized cost of energy: 0.488 \$/kWh

## Cost breakdown

Component	Initial Capital	Annualized Capital	Annualized Replacement	Annual O&M	Annual Fuel	Total Annualized
	(\$)	(\$/yr)	(\$/yr)	(\$/yr)	(\$/yr)	(\$/yr)
Generator 1	242,945	19,005	19,955	238,042	639,144	916,145
Generator 2	135,149	10,572	6,157	114,919	163,568	295,217
Other	2,743,000	214,576	0	127,700	0	342,276
Totals	3,121,094	244,153	26,112	480,661	802,711	1,553,637

## Annual electric energy production

Component	Production	Fraction
	(kWh/yr)	
Generator 1	2,594,165	82%
Generator 2	586,539	18%
Total	3,180,703	100%

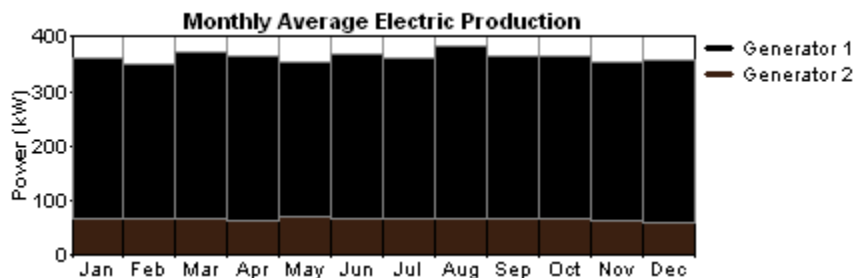

# Annual electric energy consumption

Load	Consumption	Fraction
	(kWh/yr)	
AC primary load	3,180,664	100%
Total	3,180,664	100%

Variable	Value	Units
Renewable fraction:	0.000	
Excess electricity:	32	kWh/yr
Unmet load:	309	kWh/yr
Capacity shortage:	3,074	kWh/yr

## Generator 1

Variable	Value	Units
Hours of operation:	6,199	hr/yr
Number of starts:	507	starts/yr
Operational life:	8.07	yr
Average electrical output:	418	kW
Minimum electrical output:	236	kW
Maximum electrical output:	560	kW
Annual fuel usage:	953,946	L/yr
Specific fuel usage:	0.368	L/kWh
Average electrical efficiency:	28.6	%

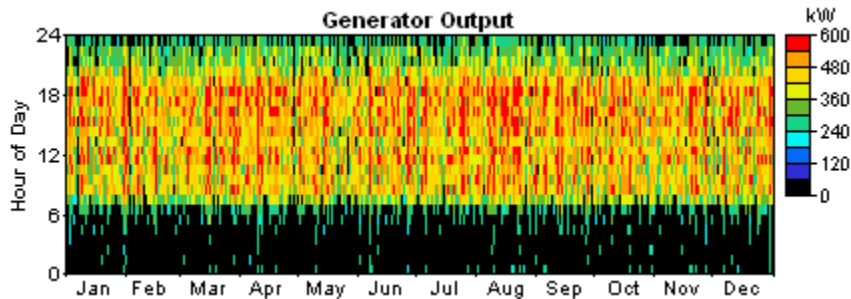

## Generator 2

Variable	Value	Units
Hours of operation:	4,353	hr/yr
Number of starts:	1,240	starts/yr
Operational life:	11.5	yr
Average electrical output:	135	kW
Minimum electrical output:	52.0	kW
Maximum electrical output:	260	kW
Annual fuel usage:	244,131	L/yr
Specific fuel usage:	0.416	L/kWh
Average electrical efficiency:	25.3	%

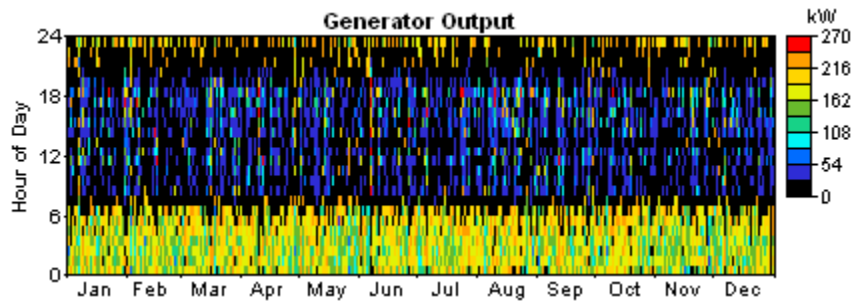



# System Report – Level 4 – Wind

This report includes only the part of the model that was simulated with Homer, and does not reflect the additional modelling as documented in Chapter 7.

## System architecture

Wind turbine: 2,500 Generic 1kW AC  
Battery: 200 Trojan T-105  
Inverter: 80 kW  
Rectifier: 80 kW

## Cost summary

Total net present cost: 91,638,216 \$  
Levelized cost of energy: 3.878 \$/kWh

## Cost breakdown

Component	Initial Capital	Annualized Capital	Annualized Replacement	Annual O&M	Annual Fuel	Total Annualized
	(\$)	(\$/yr)	(\$/yr)	(\$/yr)	(\$/yr)	(\$/yr)
Generic 1kW AC	8,967,500	701,498	96,144	250,000	0	1,047,642
Battery	73,400	5,742	4,328	400	0	10,469
Converter	197,089	15,418	5,236	82	0	20,736
Other	75,098,496	5,874,709	0	215,000	0	6,089,709
Totals	84,336,480	6,597,367	105,708	465,482	0	7,168,557

## Annual electric energy production

Component	Production	Fraction
	(kWh/yr)	
Wind turbines	5,861,559	100%
Total	5,861,559	100%

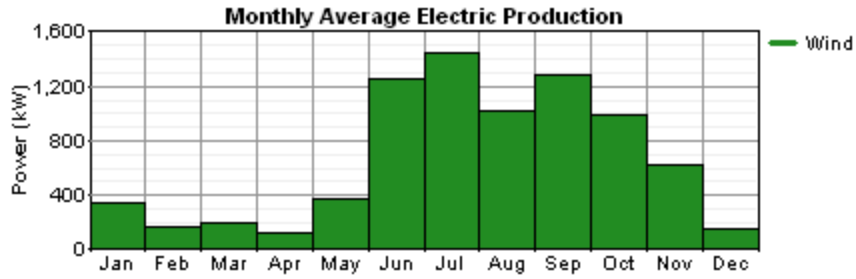

## Annual electric energy consumption

Load	Consumption	Fraction
	(kWh/yr)	
AC primary load	1,848,551	100%
Total	1,848,551	100%

Variable	Value	Units
Renewable fraction:	1.000	
Excess electricity:	4,006,794	kWh/yr
Unmet load:	1,332,053	kWh/yr
Capacity shortage:	1,817,502	kWh/yr

## AC Wind Turbine: Generic 1kW AC

Variable	Value	Units
Total capacity:	2,500	kW
Average output:	669	kW
Minimum output:	0.000	kW
Maximum output:	2,495	kW
Wind penetration:	184	%
Capacity factor:	26.8	%
Hours of operation:	7,591	hr/yr

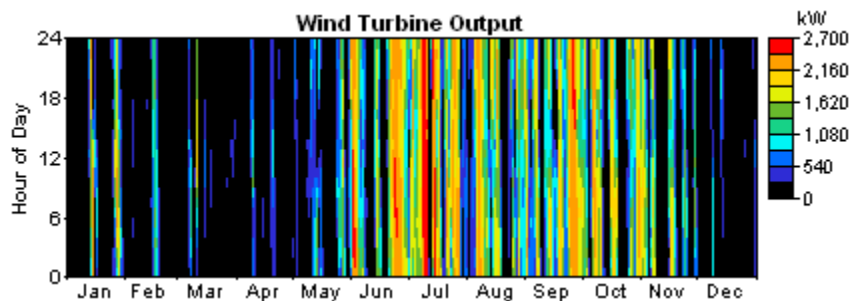

# Battery

Variable	Value	Units
Battery throughput	14,306	kWh/yr
Battery life	10.0	yr
Battery autonomy	0.357	hours

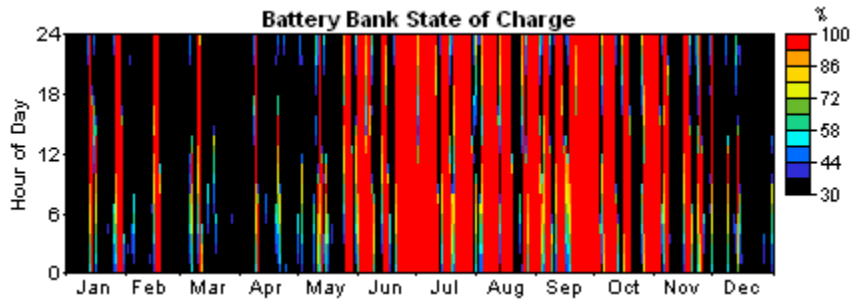
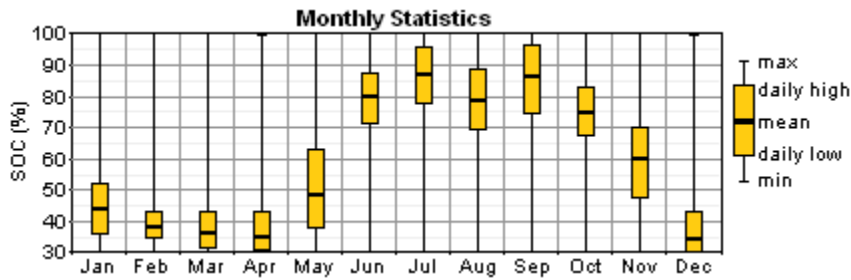
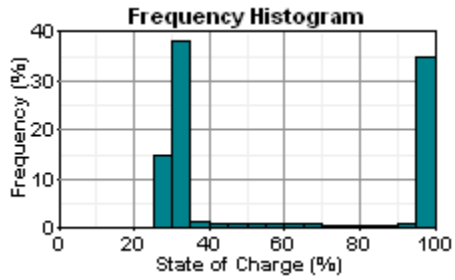

# System Report – Level 4 – Wind Diesel Hybrid

## System architecture

Wind turbine: 1,000 Generic 1kW AC  
 Generator 1: 200 kW  
 Generator 2: 470 kW  
 Battery: 400 Trojan T-105  
 Inverter: 200 kW  
 Rectifier: 200 kW  
 Dispatch strategy: Cycle Charging

## Cost summary

Total net present cost: 25,187,144 \$  
 Levelized cost of energy: 0.620 \$/kWh

## Cost breakdown

Component	Initial Capital	Annualized Capital	Annualized Replacement	Annual O&M	Annual Fuel	Total Annualized
	(\$)	(\$/yr)	(\$/yr)	(\$/yr)	(\$/yr)	(\$/yr)
Generic 1kW AC	3,587,000	280,599	38,458	100,000	0	419,057
Generator 1	103,263	8,078	3,091	42,324	352,639	406,132
Generator 2	191,460	14,977	5,159	58,377	825,476	903,990
Battery	146,800	11,484	15,929	800	0	28,213
Converter	484,556	37,905	12,873	189	0	50,967
Other	1,878,500	146,949	0	15,000	0	161,949
Totals	6,391,579	499,992	75,510	216,690	1,178,115	1,970,308

## Annual electric energy production

Component	Production	Fraction
	(kWh/yr)	
Wind turbines	2,344,594	56%

Generator 1	536,734	13%
Generator 2	1,280,234	31%
Total	4,161,562	100%

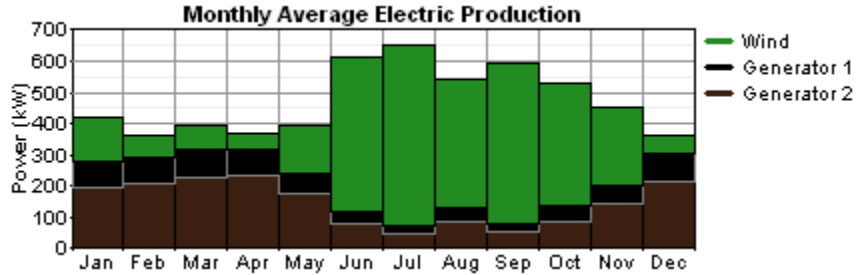

## Annual electric energy consumption

Load	Consumption	Fraction
	(kWh/yr)	
AC primary load	3,180,165	100%
Total	3,180,165	100%

Variable	Value	Units
Renewable fraction:	0.563	
Excess electricity:	958,865	kWh/yr
Unmet load:	442	kWh/yr
Capacity shortage:	2,542	kWh/yr

## AC Wind Turbine: Generic 1kW AC

Variable	Value	Units
Total capacity:	1,000	kW
Average output:	268	kW
Minimum output:	0.000	kW
Maximum output:	998	kW
Wind penetration:	73.7	%
Capacity factor:	26.8	%
Hours of operation:	7,591	hr/yr

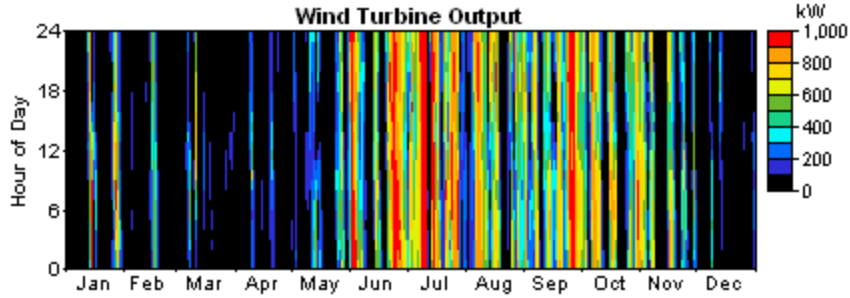

## Generator 1

Variable	Value	Units
Hours of operation:	3,527	hr/yr
Number of starts:	1,308	starts/yr
Operational life:	14.2	yr
Average electrical output:	152	kW
Minimum electrical output:	40.0	kW
Maximum electrical output:	200	kW
Annual fuel usage:	190,616	L/yr
Specific fuel usage:	0.355	L/kWh
Average electrical efficiency:	28.6	%

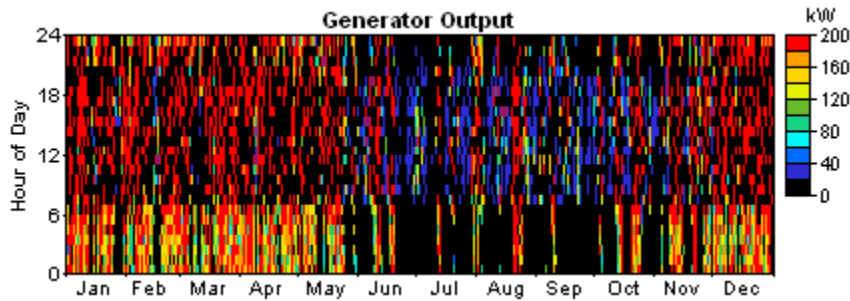

## Generator 2

Variable	Value	Units
Hours of operation:	3,355	hr/yr
Number of starts:	629	starts/yr
Operational life:	14.9	yr
Average electrical output:	382	kW
Minimum electrical output:	94.0	kW
Maximum electrical output:	470	kW

Annual fuel usage:	446,203	L/yr
Specific fuel usage:	0.349	L/kWh
Average electrical efficiency:	29.2	%

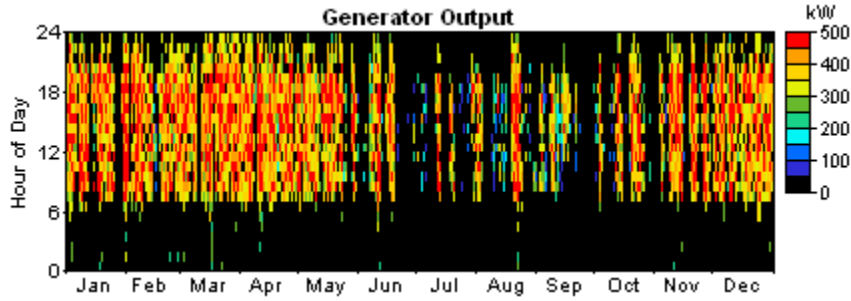

## Battery

Variable	Value	Units
Battery throughput	50,581	kWh/yr
Battery life	6.68	yr
Battery autonomy	0.714	hours

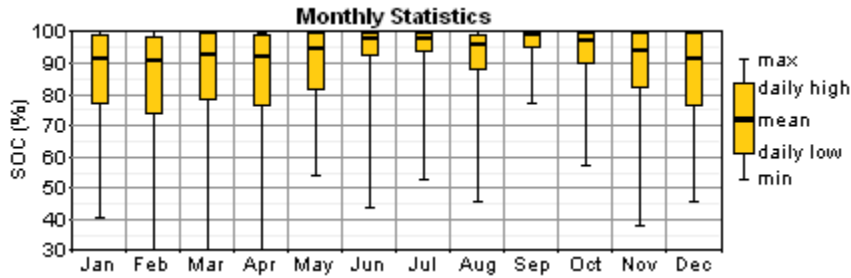
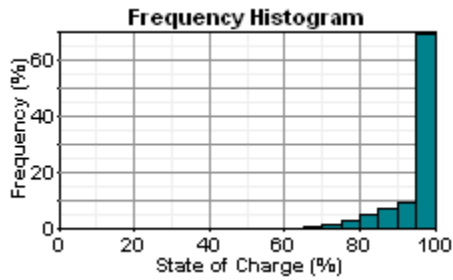

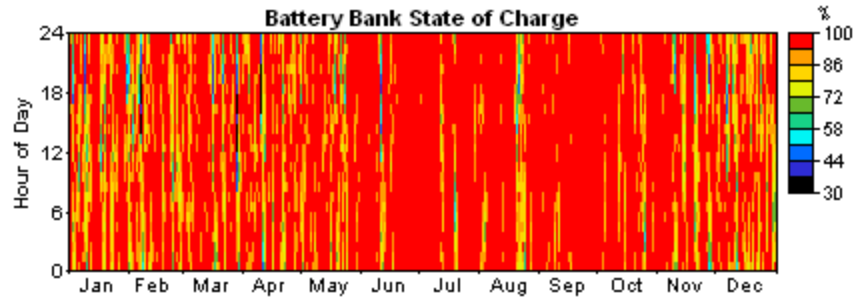



# System Report – Level 4 – Solar

## System architecture

PV Array: 3,400 kW  
Battery: 30,000 ROT-Trojan T-105  
Inverter: 900 kW  
Rectifier: 900 kW

## Cost summary

Total net present cost: 106,979,048 \$  
Levelized cost of energy: 2.633 \$/kWh

## Cost breakdown

Component	Initial Capital	Annualized Capital	Annualized Replacement	Annual O&M	Annual Fuel	Total Annualized
	(\$)	(\$/yr)	(\$/yr)	(\$/yr)	(\$/yr)	(\$/yr)
PV Array	48,212,000	3,771,467	1,280,786	1,286,667	0	6,338,919
Battery	11,010,000	861,276	649,144	60,000	0	1,570,420
Converter	2,161,445	169,083	127,438	811	0	297,332
Other	1,878,500	146,949	0	15,000	0	161,949
Totals	63,261,944	4,948,775	2,057,367	1,362,478	0	8,368,620

## Annual electric energy production

Component	Production	Fraction
	(kWh/yr)	
PV array	5,298,290	100%
Total	5,298,290	100%

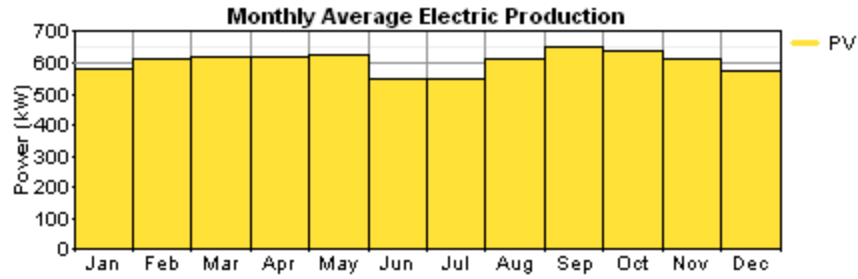

## Annual electric energy consumption

Load	Consumption	Fraction
	(kWh/yr)	
AC primary load	3,178,827	100%
Total	3,178,827	100%

Variable	Value	Units
Renewable fraction:	1.000	
Excess electricity:	1,501,333	kWh/yr
Unmet load:	2,146	kWh/yr
Capacity shortage:	3,077	kWh/yr

## PV

Variable	Value	Units
Average output:	14,516	kWh/d
Minimum output:	0.000799	kW
Maximum output:	3,592	kW
Solar penetration:	167	%
Capacity factor:	17.8	%
Hours of operation:	4,761	hr/yr

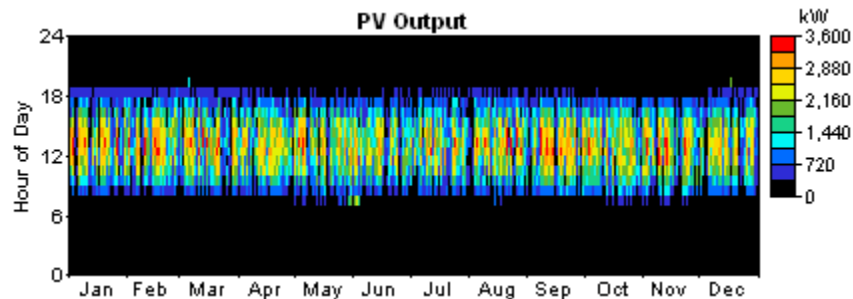

# Battery

Variable	Value	Units
Battery throughput	1,701,200	kWh/yr
Battery life	10.0	yr
Battery autonomy	78.1	hours

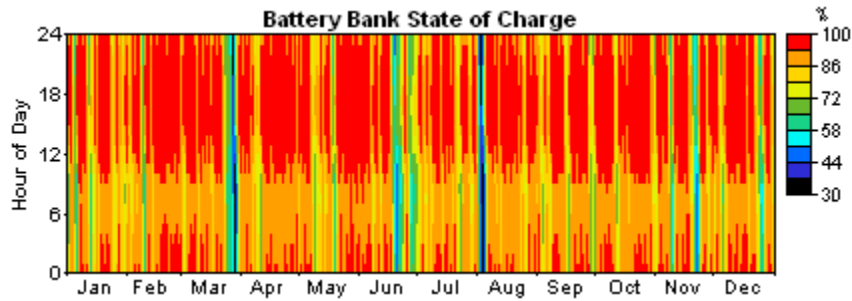
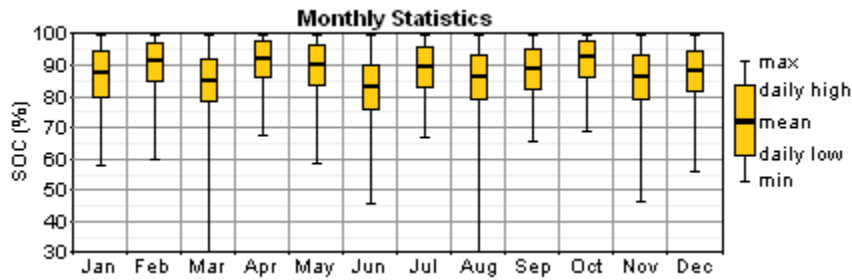
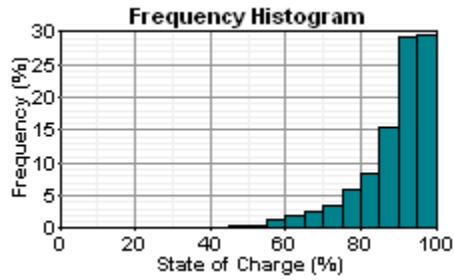

# System Report – Level 4 – Solar Diesel Hybrid

## System architecture

PV Array: 1,250 kW  
 Generator 1: 360 kW  
 Generator 2: 200 kW  
 Battery: 400 ROT-Trojan T-105  
 Inverter: 600 kW  
 Rectifier: 600 kW  
 Dispatch strategy: Cycle Charging

## Cost summary

Total net present cost: 52,093,412 \$  
 Levelized cost of energy: 1.281 \$/kWh

## Cost breakdown

Component	Initial Capital	Annualized Capital	Annualized Replacement	Annual O&M	Annual Fuel	Total Annualized
	(\$)	(\$/yr)	(\$/yr)	(\$/yr)	(\$/yr)	(\$/yr)
PV Array	17,739,334	1,387,690	471,258	474,444	0	2,333,392
Generator 1	155,528	12,166	4,506	52,759	717,334	786,766
Generator 2	103,263	8,078	5,486	56,544	488,008	558,116
Battery	146,800	11,484	24,116	800	0	36,399
Converter	1,442,778	112,864	85,065	544	0	198,474
Other	1,878,500	146,949	0	15,000	0	161,949
Totals	21,466,204	1,679,231	590,431	600,092	1,205,342	4,075,097

## Annual electric energy production

Component	Production	Fraction
	(kWh/yr)	
PV array	1,947,898	51%

Generator 1	1,151,115	30%
Generator 2	753,585	20%
Total	3,852,599	100%

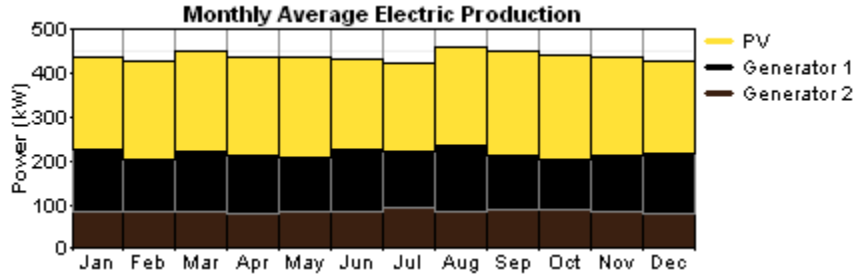

## Annual electric energy consumption

Load	Consumption	Fraction
	(kWh/yr)	
AC primary load	3,180,094	100%
Total	3,180,094	100%

Variable	Value	Units
Renewable fraction:	0.506	
Excess electricity:	506,464	kWh/yr
Unmet load:	879	kWh/yr
Capacity shortage:	2,892	kWh/yr

## PV

Variable	Value	Units
Average output:	5,337	kWh/d
Minimum output:	0.000294	kW
Maximum output:	1,321	kW
Solar penetration:	61.2	%
Capacity factor:	17.8	%
Hours of operation:	4,761	hr/yr

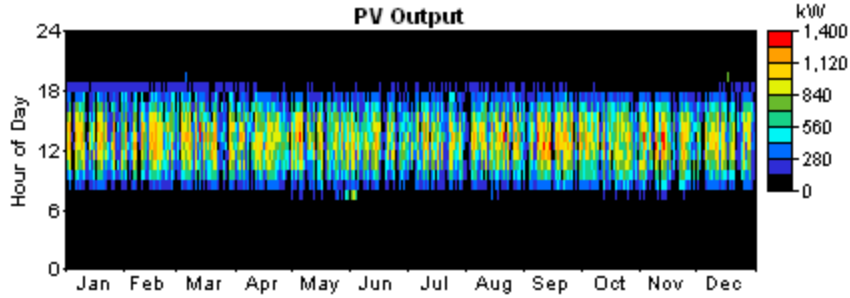

## Generator 1

Variable	Value	Units
Hours of operation:	3,471	hr/yr
Number of starts:	874	starts/yr
Operational life:	14.4	yr
Average electrical output:	332	kW
Minimum electrical output:	128	kW
Maximum electrical output:	360	kW
Annual fuel usage:	387,748	L/yr
Specific fuel usage:	0.337	L/kWh
Average electrical efficiency:	30.2	%

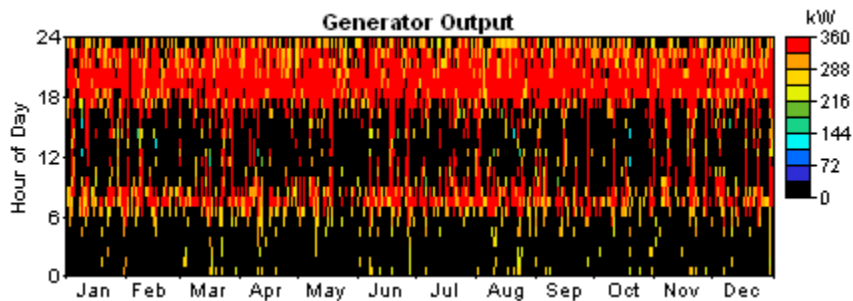

## Generator 2

Variable	Value	Units
Hours of operation:	4,712	hr/yr
Number of starts:	1,510	starts/yr
Operational life:	10.6	yr
Average electrical output:	160	kW
Minimum electrical output:	40.0	kW
Maximum electrical output:	200	kW

Annual fuel usage:	263,788	L/yr
Specific fuel usage:	0.350	L/kWh
Average electrical efficiency:	29.0	%

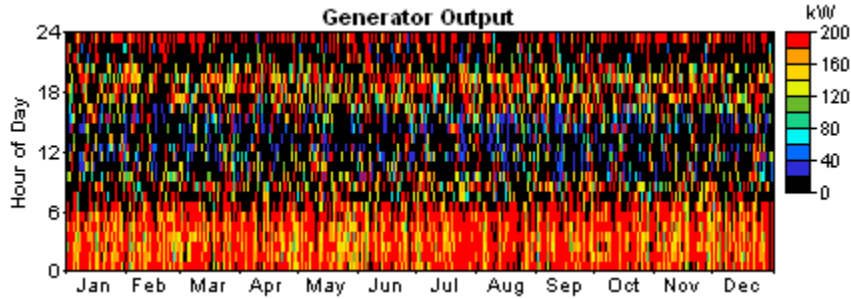

## Battery

Variable	Value	Units
Battery throughput	69,202	kWh/yr
Battery life	4.88	yr
Battery autonomy	1.04	hours

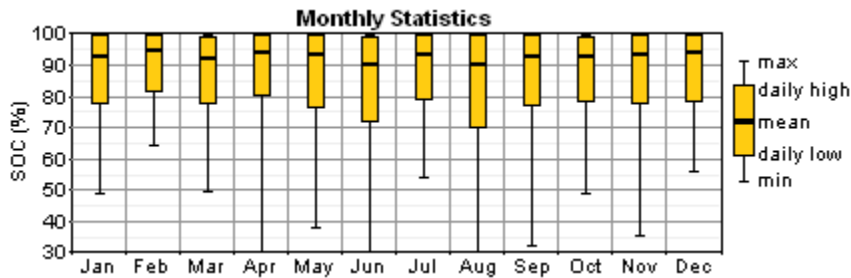
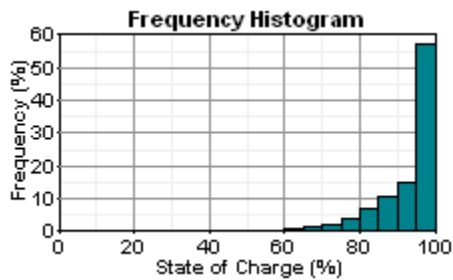

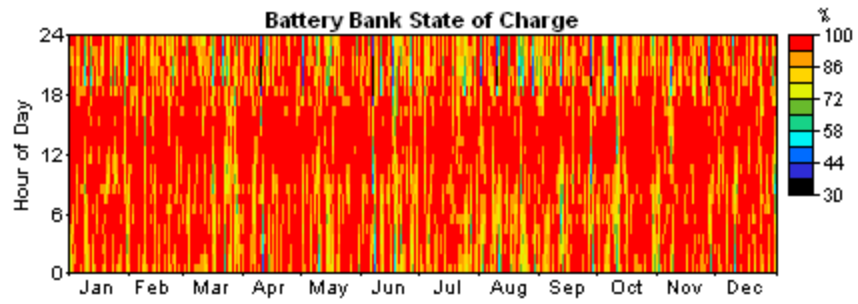



## **Appendix D – Risk Analysis Spreadsheets**

***I. Risk of all individual energy system concepts***

***II. Common risk of service levels***

***III. Risk summation sheet***

Feasibility	1
	2
Fundamental	1
	2
	3
	4
	5
Technical	1
	2
	3
	4
	5
Application	1
	2
	3
	4
	5
Costs	1
	2
	3
	4
	5
<b>FEASIBILITY SUMS</b>	
Resource sec/Nat disasters	1
	2
	3
	4
	5
<b>RESOURCE SUMS</b>	
Environmental	1
	2
	3
	4
	5
	6
	7
	8
	9
	10
<b>ENVIRONMENTAL SUMS</b>	

Diesel				Copra												
B	i	p	r	B	i	p	r	B	i	p	r	B	i	p	r	C
			0				0				0					0
			0				0				0					0
none			0	none			0	Engine problems due to coconut oil ca	3	4	12	Engine problems due to coconut oil ca	3	3	9	
			0				0				0					0
			0				0				0					0
			0				0				0					0
			0				0				0					0
none			0	none			0	Failure of coconut oil conversion equip	4	3	12	Failure of coconut oil conversion equip	3	3	9	
			0				0				0					0
			0				0				0					0
			0				0				0					0
			0				0				0					0
Repair delays due to long turnar	2	4	8	Repair delays due to long turnaround t	2	3	6	Repair delays due to long turnaround t	3	4	12	Repair delays due to long turnaround t	3	3	9	
Damage to plant due to improper	3	2	6	Damage to plant due to improper use	3	1	3	Damage to plant due to improper use	3	4	12	Damage to plant due to improper use	3	2	6	
			0				0				0					0
			0				0				0					0
			0				0				0					0
Continuous financing problems	4	2	8	Continuous financing problems	4	4	16	Continuous financing problems	4	2	8	Continuous financing problems	4	3	12	
Difficulties finding initional lender	5	2	10	Difficulties finding initional lender due t	5	3	15	Difficulties finding initional lender due t	5	2	10	Difficulties finding initional lender due t	5	3	15	
			0				0				0					0
			0				0				0					0
			0				0				0					0
			0				0				0					0
			32				40				66					60
System disruptions by 50\% petr	4	5	20	System disruptions by 50\% petroleum	4	5	20	Plant repair difficulties due to 50\% rec	3	5	15	Plant repair difficulties due to 50\% rec	3	4	12	
Plant repair difficulties due to 50\	2	5	10	Plant repair difficulties due to 50\% rec	2	4	8	Local supply problems due to dramatic	2	2	4	Local supply problems due to dramatic	4	2	8	
Damage of plant due to hurricane	1	3	3	Damage of plant due to hurricane strik	1	3	3	Supply shortage due to hurricane strik	1	3	3	Supply shortage due to hurricane strik	2	3	6	
			0				0				0					0
			0				0				0					0
			0				0				0					0
			0				0				0					0
			0				0				0					0
			33				31				22					26
Accumulation of old machinery, e	1	1	1	Accumulation of old machinery, excl. b	1	2	2	Accumulation of old machinery, excl. b	1	2	2	Accumulation of old machinery, excl. b	1	2	2	
Large scale contamination of soil	3	1	3	Large scale contamination of soil/grou	3	1	3	Large scale contamination of soil/grou	3	1	3	Large scale contamination of soil/grou	3	1	3	
Soil/groundwater contamination e	4	2	8	Soil/groundwater contamination due to	4	1	4	Habitat destruction due to land require	3	1	3	Habitat destruction due to land require	3	1	3	
Sea contamination due to petrole	4	1	4	Sea contamination due to petroleum fu	4	2	8	Local air pollution due to engine exhau	1	1	1	Local air pollution due to engine exhau	1	1	1	
Local air pollution due to engine	2	2	4	Local air pollution due to engine exhau	1	1	1	Noise pollution due to plant operation	1	5	5	Noise pollution due to plant operation	1	1	1	
Noise pollution due to plant oper	1	5	5	Noise pollution due to plant operation	1	1	1				0					0
			0				0				0					0
			0				0				0					0
			0				0				0					0
			0				0				0					0
			0				0				0					0
			25				19				14					10

D	i p r			Wind			Wind-Diesel			C			i p r		
				B			B								
			0			0									0
			0			0									0
Engine problems due to coconut oil ca	3	2	6	Premature turbine failure due to corros	3	2	6	Premature turbine failure due to corros	3	2	6	Premature turbine failure due to corros	3	1	3
			0			0					0				0
			0			0					0				0
			0			0					0				0
			0			0					0				0
Failure of coconut oil conversion equip	3	3	9			0					0	Power quality problems due to high wi	1	4	4
			0			0					0				0
			0			0					0				0
			0			0					0				0
			0			0					0				0
Repair delays due to long turnaround t	3	3	9	Repair delays due to long turnaround t	2	4	8	Repair delays due to long turnaround t	2	4	8	Repair delays due to long turnaround t	2	3	6
Damage to plant due to improper use	3	2	6	Damage to plant due to improper use	3	3	9	Damage to plant due to improper use	3	4	12	Damage to plant due to improper use	3	2	6
			0			0					0				0
			0			0					0				0
			0			0					0				0
Continuous financing problems	4	3	12	Continuous financing problems	4	5	20	Continuous financing problems	4	4	16	Continuous financing problems	4	4	16
Difficulties finding initional lender due t	5	2	10	Difficulties finding initional lender due t	5	5	25	Difficulties finding initional lender due t	5	4	20	Difficulties finding initional lender due t	5	3	15
			0			0					0				0
			0			0					0				0
			0			0					0				0
			0			0					0				0
			52			68					62				50
Plant repair difficulties due to 50% rec	3	4	12	Plant repair difficulties due to 50% rec	2	5	10	System disruptions by 50% petroleum	3	5	15	System disruptions by 50% petroleum	3	5	15
Local supply problems due to dramatic	5	2	10	Damage of plant due to hurricane strik	3	3	9	Plant repair difficulties due to 50% rec	2	5	10	Plant repair difficulties due to 50% rec	2	4	8
Supply shortage due to hurricane strik	4	3	12	Wind resource problems due to two m	3	3	9	Damage of plant due to hurricane strik	3	3	9	Damage of plant due to hurricane strik	3	3	9
			0			0		Wind resource problems due to two m	2	3	6	Wind resource problems due to two m	2	3	6
			0			0					0				0
			34			28					40				38
Accumulation of old machinery, excl. b	1	3	3	Accumulation of old machinery, excl. b	1	1	1	Accumulation of old machinery, excl. b	1	2	2	Accumulation of old machinery, excl. b	1	3	3
Large scale contamination of soil/grou	3	1	3	Soil/groundwater contamination due to	4	4	16	Large scale contamination of soil/grou	3	1	3	Large scale contamination of soil/grou	3	1	3
Habitat destruction due to land require	3	2	6	Soil/groundwater contamination due to	5	4	20	Soil/groundwater contamination due to	4	1	4	Soil/groundwater contamination due to	4	1	4
Local air pollution due to engine exhau	1	1	1	Habitat destruction due to land require	3	1	3	Sea contamination due to petroleum fu	4	1	4	Sea contamination due to petroleum fu	4	1	4
Noise pollution due to plant operation	1	1	1	Noise pollution due to plant operation	1	5	5	Soil/groundwater contamination due to	4	3	12	Soil/groundwater contamination due to	4	3	12
			0			0		Soil/groundwater contamination due to	5	3	15	Soil/groundwater contamination due to	5	3	15
			0			0		Habitat destruction due to land require	3	1	3	Decimation of bird populations due to l	2	2	4
			0			0		Local air pollution due to engine exhau	1	2	2	Habitat destruction due to land require	3	1	3
			0			0		Noise pollution due to plant operation	1	5	5	Local air pollution due to engine exhau	1	1	1
			0			0					0	Noise pollution due to plant operation	1	3	3
			14			45					50				52

D	i p r			Solar B			Solar-Diesel B				
			0						0		
			0						0		
Premature turbine failure due to corrosion	3	1	3	Premature PV panel failure due to corrosion	3	2	6	Premature PV panel failure due to corrosion	3	2	6
			0				0				0
			0				0				0
			0				0				0
			0				0				0
Power quality problems due to high wind	1	3	3				0				0
			0				0				0
			0				0				0
			0				0				0
			0				0				0
Repair delays due to long turnaround times	2	3	6	Repair delays due to long turnaround times	4	4	16	Repair delays due to long turnaround times	3	4	12
Damage to plant due to improper use	3	2	6	Damage to plant due to improper use	3	3	9	Damage to plant due to improper use	3	3	9
			0				0				0
			0				0				0
			0				0				0
Continuous financing problems	4	5	20	Continuous financing problems	4	5	20	Continuous financing problems	4	4	16
Difficulties finding initial lender due to	5	3	15	Difficulties finding initial lender due to	5	5	25	Difficulties finding initial lender due to	5	4	20
			0				0				0
			0				0				0
			0				0				0
			0				0				0
			53				76				63
System disruptions by 50% petroleum	3	5	15	Plant repair difficulties due to 50% reduction	4	5	20	System disruptions by 50% petroleum	3	5	15
Plant repair difficulties due to 50% reduction	2	4	8	Damage of plant due to hurricane strike	4	3	12	Plant repair difficulties due to 50% reduction	3	5	15
Damage of plant due to hurricane strike	3	3	9	Solar resource problems due to three variables	4	3	12	Damage of plant due to hurricane strike	2	3	6
Wind resource problems due to two variables	2	3	6				0	Solar resource problems due to three variables	2	3	6
			0				0				0
			38				44				42
Accumulation of old machinery, excluding batteries	1	3	3	Accumulation of old machinery, excluding batteries	2	3	6	Accumulation of old machinery, excluding batteries	1	2	2
Large scale contamination of soil/groundwater	3	1	3	Soil/groundwater contamination due to	4	4	16	Large scale contamination of soil/groundwater	3	1	3
Soil/groundwater contamination due to	4	1	4	Soil/groundwater contamination due to	5	4	20	Soil/groundwater contamination due to	4	1	4
Sea contamination due to petroleum fuel	4	2	8	Habitat destruction due to land requirements	3	1	3	Sea contamination due to petroleum fuel	4	1	4
Soil/groundwater contamination due to	4	3	12				0	Soil/groundwater contamination due to	4	3	12
Soil/groundwater contamination due to	5	3	15				0	Soil/groundwater contamination due to	5	3	15
Decimation of bird populations due to	2	3	6				0	Habitat destruction due to land requirements	3	1	3
Habitat destruction due to land requirements	3	1	3				0	Local air pollution due to engine exhaust	1	2	2
Local air pollution due to engine exhaust	1	1	1				0	Noise pollution due to plant operation	1	5	5
Noise pollution due to plant operation	1	3	3				0				0
			58				45				50

## **Appendix D – Homer Models and Outputs**

*I. Risk of all individual energy system concepts*

***II. Common risk of service levels***

*III. Risk summation sheet*

Feasibility	1
	2
	3
	4
	5
Fundamental	1
	2
	3
	4
	5
Application	1
	2
	3
	4
<b>FEASIBILITY SUMS</b>	
Cultural dilution	1
	2
	3
	4
	5
	6
	7
	8
	9
	10
<b>CULTURE SUMS</b>	
Environmental	1
	2
	3
	4
	5
<b>ENVIRO SUMS</b>	

A	i	p	r	B	i	p	r	C	i	p	r	D	i	p	r
Service level developmen	5	4	20	Service level with conseq	5	2	10	Service level with conseq	5	3	15	Service level with conseq	5	5	25
			0				0				0				0
			0				0				0				0
			0				0				0				0
			0				0				0				0
			0	High cost of supply of goc	1	4	4	High cost of supply of goc	2	4	8	High cost of supply of goc	4	4	16
			0				0				0				0
			0				0				0				0
			0				0				0				0
			0				0				0				0
			0				0				0				0
			0				0				0				0
			0				0				0				0
			0				0				0				0
			0				0				0				0
			0				0				0				0
			20				14				23				41
			0	Reduction/gradual loss of	4	2	8	Reduction/gradual loss of	4	3	12	Reduction/gradual loss of	4	5	20
			0	Reduction/gradual loss of	5	2	10	Reduction/gradual loss of	5	4	20	Reduction/gradual loss of	5	5	25
			0	Reduction/gradual loss of	4	3	12	Reduction/gradual loss of	4	4	16	Reduction/gradual loss of	4	5	20
			0	Reduction/gradual loss of	5	1	5	Reduction/gradual loss of	5	2	10	Reduction/gradual loss of	5	4	20
			0				0				0				0
			0				0				0				0
			0				0				0				0
			0				0				0				0
			0				0				0				0
			0				0				0				0
			0				0				0				0
			0				0				0				0
			0				0				0				0
			0				0				0				0
			0				0				0				0
			0				0				0				0
			0				0				0				0
			0				0				0				0
			0	Soil/groundwater contami	3	3	9	Soil/groundwater contami	4	4	16	Soil/groundwater contami	5	4	20
			0				9				16				20



## **Appendix D – Homer Models and Outputs**

***I. Risk of all individual energy system concepts***

***II. Common risk of service levels***

***III. Risk summation sheet***

Level	Concept	level wide		concept wide			Tot
		Culture	Feasibilit	Feasibility	Resource	Envi.	
Level A	-	0	20	-	-	-	20
Level B	Diesel	35	14	32	33	34	148
	Copra	35	14	66	22	23	160
	Wind	35	14	68	28	54	199
	Wind-Hybrid	35	14	62	40	59	210
	Solar	35	14	76	44	54	223
	Solar-Hybrid	35	14	63	42	59	213
Level C	Diesel	58	23	40	31	35	187
	Copra	58	23	60	26	26	193
	Wind	58	23	n/t	-	-	81
	Wind-Hybrid	58	23	50	38	68	237
	Solar	58	23	n/t	-	-	81
	Solar-Hybrid	58	23	n/t	-	-	81
Level D	Diesel	85	41	n/t	-	-	126
	Copra	85	41	52	34	34	246
	Wind	85	41	n/t	-	-	126
	Wind-Hybrid	85	41	53	38	78	295
	Solar	85	41	n/t	-	-	126
	Solar-Hybrid	85	41	n/t	-	-	126

Key	
	Not feasible or at least one high risk
	At least one med. risk
	Only low risks
	n/a
	not feasible

## **Appendix E – Peer Reviewed Papers**

***I. Submission draft: Energy Resource Paper, to be submitted to "Renewable Energy"***

***II. ICSES Conference Paper***

**Products****Renewable Energy****Journal information**

Product description  
Editorial board  
Audience  
Abstracting/indexing  
Special issues and supplements

**Subscription information**

Bibliographic and ordering information  
Conditions of sale  
Dispatch dates

**Journal related information**

Impact factor  
Most downloaded articles  
Other journals in same subject area  
Related publications

**Support & contact****About Elsevier****Select your view****RENEWABLE ENERGY**

An International Journal  
The Official Journal of WREN - The World  
Renewable Energy Network

**Editor-in-Chief:****A.A.M. Sayigh**

See [editorial board](#) for all editors  
information

**Description**

The journal seeks to promote and disseminate knowledge of the various topics and technologies of renewable energy and is therefore aimed at assisting researchers, economists, manufacturers, world agencies and societies to keep abreast of new developments in their specialist fields and to unite in finding alternative energy solutions to current issues such as the greenhouse effect and the depletion of the ozone layer.

The scope of the journal encompasses the following:  
Photovoltaic Technology Conversion, Solar Thermal Applications, Biomass Conversion, Wind Energy Technology, Materials Science Technology, Solar and Low Energy Architecture, Energy Conservation in Buildings, Climatology and Meteorology (Geothermal, Wave and Tide, Ocean Thermal Energies, Mini Hydro Power and Hydrogen Production Technology), Socio-economic and Energy Management.

*Renewable Energy* accepts original research papers or any other original contribution in the form of reviews and reports on new concepts. It promotes innovations, papers of a tutorial nature and a general exchange of news, views and new books on the above subjects.

**Bibliographic & ordering Information**

ISSN: 0960-1481  
Imprint: PERGAMON  
Commenced publication 1985

Subscriptions for the year 2008, Volume 33, 12 issues

**Institutional online access:** [ScienceDirect eSelect](#)

For purchase of online access to this journal on ScienceDirect by credit card.

**Institutional price:** [Order form](#)

EUR 2,041 for European countries and Iran  
JPY 271,000 for Japan  
USD 2,283 for all countries except Europe, Japan and Iran

See also information about [conditions of sale & ordering procedures](#), and links to our [regional sales offices](#).

For an overview of recent dispatched issues, see the Journal issue [dispatch dates](#)

**Audience**

Engineers, architects, technicians interested in and working with energy systems, scientists and engineers in the underdeveloped/developing countries, industries, manufacturers, inventors, universities, researchers and consultants.

**Impact factor of this journal**

2006: 0.850  
Journal Citation Reports® 2007, published by Thomson Scientific

607/580

Last update: 22 Oct 2007

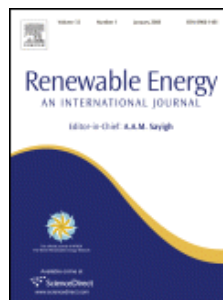
**For Readers**

[Free Tables of contents and abstracts](#)  
[Full text in ScienceDirect](#)  
[Sample issue](#)  
[Free volume/issue alert](#)

**For Authors**

[Guide for authors](#)  
[Submit your article](#)  
[Track your accepted article](#)

**For Editors**

[Tracking for Editors](#)

**For Societies**

[World Renewable Energy Network \(WREN\)](#)

**Related websites**

[Artwork Instructions](#)

Search through the articles of this journal powered by [Scirus](#)

Search by keywords

Search by author

[Bookmark this page](#)

[Recommend this publication](#)

[Overview of all journals](#)



[Printer-friendly version](#)

# Opportunities and Challenges for Alternative Energy for the Remote Pacific Island of Rotuma

Andreas Hamm\*, Susan Krumdieck, Mark Jermy

All: Department of Mechanical Engineering, University of Canterbury, New Zealand

\*corresponding author

[Samarti@gmail.com](mailto:Samarti@gmail.com)

Tel: 0064 3 364-2478

## Abstract

Energy use for modern conveniences on Pacific Islands poses particular challenges because of the high degree of isolation. Many renewable energy projects have been implemented, but with limited success. Background research and a four-month field study resulted in a detailed energy survey of residential energy services and an assessment of the renewable energy resources. Rotumans are frustrated with an unreliable, yet expensive Diesel-based electricity system. The lack of reliable and accurate data for remote locations can be a barrier to lower cost renewable energy development. Current estimations of wind resources for many Pacific Islands are developed from unreliable weather data. The field work involved measurement of wind data at strategic sites on the island. A high resolution wind map of Rotuma was generated on the basis of synoptic climate data and topographical features and validated with the measurements. This wind resource map shows that there are many suitable wind sites on the island, while the previously available information indicated that wind energy development would be unfeasible. However, the viability of wind energy depends on a number of specific constraining factors, for example disposal of batteries for small systems or logistics of installation for large turbines. Lessons learned from the Rotuma experience are of value for renewable energy assessments in remote environmentally and culturally sensitive locations.

*Keywords:* Remote power; wind; solar; coconut oil; energy survey; Pacific Islands

## 1 Introduction

Energy use on Pacific Islands poses particular challenges because of the high degree of isolation. In Pacific Island countries, economic activities are concentrated on the few biggest islands leaving the majority of islands isolated [1]. Often, only a few hundred people live on isolated islands, separated by multiple hour boat rides from the closest economic centers. Rural electrification schemes using mainly diesel generators have been implemented on many islands under substantial government funding. It was anticipated that electrification would create business opportunities and spur economic development [2]. This way, rural electrification projects were expected to perpetuate themselves. This hardly ever occurred. The Fijian Energy Department reports that their Fiji Rural Electrification Policy did not work [2]. The author noted that Pacific Islanders

often showed little interest in engaging in business activities even when they had the opportunity. Because of the extreme isolation, fuel distribution to the islands has always been disproportionately expensive. This was a contributing factor why Pacific islands were seen as ideal substrate for renewable energy programs. According to the World Bank [3] Pacific Island governments had high expectation for the development of indigenous energy resources and succumbed to it.

The overall extremely low success rate at rural electrification in Pacific Islands indicates a need for a better understanding of energy related issues.

This study investigates energy use and potential alternative energy resources for Rotuma. While special in some ways, Rotuma is a good model for isolated Pacific Islands, the full range of energy related issues listed above being observable on the island. Rotuma has a permanent population of 2500. It is located 500km Northwest of Cikobia, the northernmost island in the Fiji group. Rotuma has 32 main villages located around the perimeter of the island. The island is approximately 15km long and 4km wide. A map of Rotuma is shown in Fig. 1. Parts of the island are too rocky or too steep for cultivation; thus about 30% of the island is covered in native bush [4]. Rotuma is of volcanic origin and dates back to Pleistocene age [5]. The main island has an area of 43km<sup>2</sup> and, except for a small opening around Oinafa point, is surrounded by a fringing coral reef. The Köppen-Geiger system classifies Rotuma's climate as *Af*, a hot and humid tropical forest climate. Monthly average temperatures lie above 25°C and average monthly rainfalls above 200mm year-round.

Despite of relatively strong Western influence, most people are fully ingrained in their traditional way of live of subsistence farming. Traditional transportation by canoes has been replaced by bus, trucks and motorbikes on the main road around the perimeter of the island. The link to the closest neighbor, Fiji, is by a monthly boat service and bi-weekly flights by small aircraft. The majority of people live in simple concrete structures with corrugated iron roofs [6]. The dried coconut flesh (copra) has been the traditional mainstay of the Rotuman economy, and may still be considered one of the most reliable sources of income to Rotumans. Remittances from relatives in Fiji and oversees play a significant role in Rotuma's economy. [7]

In this paper, the energy needs and resources of the island of Rotuma are surveyed. The survey methodology is presented and the wind, solar, and biomass (copra) resources are quantified. Finally, the resources are analyzed in terms of current and future requirements and some conclusions for development options of the energy system are drawn.

## **2 Rotuma's Energy System**

At present, Rotuma has a limited electricity supply based on distributed diesel generation. There are 18 independent village mini grids on Rotuma, each serving between 10 and 50 households. Each grid has one generator, with capacities ranging from 6 to 40kVA. All grids are designed for 240V transmission. Although a number of three phase generators are installed, only single phase loads are supplied on Rotuma. It is interesting to note that

all three phase generators on the island are improperly connected with severe phase imbalances, leading to very low system efficiencies.

The mini grids are operated for a limited period of time, between 2 and 6 hours per day. All generators are switched on around sun set (18:00 to 19:00), and turned off between 21:00 and 23:00. Some villages run their generators for an additional two hours in the morning before sun rise. The village electricity systems serve almost exclusively domestic loads.

All generators and grids have been installed by Fiji's Department of Energy (DoE). Within their rural electrification scheme, the DoE pays 90% of all costs upon installation and transfers ownership to the villages after three years.

Electricity costs vary from village to village and range from \$10 (Juju) to \$50 (Motusa) per household per month. Electricity meters are installed in some villages, but electricity is almost exclusively charged out on flat rate bases with minimal penalties for high users. Periodical electricity charges only pay for the diesel bill. At the present charging scheme, three months meter records for Motusa in 2006 indicated that, effectively, households paid between \$1 and \$85 or a mean of \$14 per kWh of delivered electricity. This is a situation where low users significantly subsidize high users. The high specific electricity costs are due to a combination of high diesel prices and improper installation and operation of the system.

All other expenses, such as generator repair, are paid for by community fundraising activities. However, fundraising difficulties in case of generator failures contribute to extremely long supply disruptions typical for the island.

### **3 Energy Demand Patterns**

#### ***3.1 Energy survey methodology***

Domestic energy surveys were carried out in line with the energy auditing guidelines in Turner [8]. The domestic energy survey focuses on domestic appliances but, for completeness, also includes energy use for cooking. The thermal envelope was not surveyed because there is no domestic air conditioning and no need for space heating on Rotuma. The survey was carried out in the form of structured interviews. For practical reasons, households were chosen by the convenience sampling method, where households are randomly picked if available. Potential systematic errors associated with this method [9] were mitigated by conducting the surveys at different times of day in order to avoid meeting only particular social groups. Only one visited household was unwilling to participate in the survey. A total of 41 interviews were held representing 9% of all households on the island. Surveys were carried out in the three villages of Juju, Losa, and Motusa.

#### ***3.2 Survey results***

The average appliance penetration for villages on Rotuma is shown in Fig. 2.

By far the most important energy service is lighting, and the need for lighting determines the generator schedules. The value of 85% means that 85% of households have electric lighting installed. Lighting is generally the first appliance people install when electricity access becomes available. On average, 3.5 luminaires were installed per household. By far the most common type of luminaires is the 18W fluorescent tube (85%), followed by the long 36W tube (8%) and incandescent light bulbs (7%). With an average ownership of 37%, televisions are the second most popular appliance. Except for an expensive and seldom used satellite service, there is no TV reception on the island. Most televisions are thus exclusively used for watching DVDs. DVDs are widely available from small “out of the window” rental shops all across the island. It is important to note that, despite of the limited TV ownership, effectively everyone has access to it: households on the island are fairly open, and if a TV is running in one home, anyone would be able to join. Stereos are widely available, but tend to be used only for special occasions.

Electric clothes irons are popular but have limited use: most villages ban their use because of high power use and proneness to overload the generators. Popular alternatives are charcoal and benzene irons. Irons have social importance on Rotuma. People are meticulous at keeping school uniforms as well as Sunday church dresses ironed.

Despite relatively high ownerships of freezers and refrigerators, reliable refrigeration is difficult with the short electricity hours in the villages. Measurements on Rotuma showed that, depending on contents, some refrigerators do not even cool down to operating temperature during four hours of electricity. Most refrigerators or freezers surveyed were empty at the time of survey or had, perhaps, two water bottles inside. When asked, people claimed to use refrigerators mostly for keeping fish cool if there is a surplus.

Ownership of washing machines is relatively high, but two factors limit their usefulness on Rotuma: following the need for lighting, electricity is mostly available in the evenings, however, this is when Rotuma’s intermittent water supply is not available. Also, in Rotuma’s damp tropical climate washing would often have a rotting smell by the morning if washed and hung up to dry in the evening.

The outline of appliance use on Rotuma throws up a seldom asked question: where do the appliances come from? The interesting answer is that many appliances are actually brought to the island as gifts from relatives. Not all of the appliances showing up in the survey are actually used due to restrictions put in place as a result of communal decisions in order to avoid overloading the generators. For example, the adverse effect of electric irons is well understood and irons are banned in most mini grids on Rotuma. The people of Rotuma are used to adapt their electricity use to generation capacity.

A loadcurve (Fig. 3) for an average village on Rotuma was derived by [10]. The average village has 120 people living in 32 households. The loadcurve shows a peak of 4kW. If allowing for daily as well as hourly noise, the design peak load becomes 6.8KW.



If an island wide grid was considered, the current village loads would add up to a peak load of 122kW, and an average daily energy use of 234kWh per day.

## 4 Alternative Energy Resources

A range of alternative energy resources for Rotuma was surveyed. Hydro power is not possible on Rotuma due to the lack of fresh water bodies on the island. Marine power was not considered because of the notable lack of commercial technologies to harness any form of marine power. As the three most promising energy resources, detailed analyses were performed to investigate the solar energy, the wind, and the coconut oil potentials on Rotuma. It is important to note that solar energy and wind power in island energy system configurations require some forms of generally expensive energy storage.

### 4.1 Solar assessment

#### 4.1.1 Methodology

The solar energy potential on Rotuma is estimated on the basis of sunshine hour data for the years 2000 to 2005. Daily sunshine hours were recorded by the Fiji Department of Meteorology at the weather station at Ahau using a Campbell Stokes sunshine recorder. Monthly average irradiation,  $H$ , has been determined using Page's modified Angstrom type regression equation [11]

$$H = H_0 \left( a + b \frac{n}{N} \right),$$

where  $H_0$  is the radiation outside the atmosphere for the same location, averaged over the month in question,  $a$  and  $b$  are location constants, and  $N$  the monthly average maximum possible daily hours of bright sunshine. Constants  $a$  and  $b$  are chosen according to [12] for a tropical forest climate and broadleaf evergreen vegetation as  $a = 0.28$  and  $b = 0.39$ .  $H_0$  is calculated as

$$H_0 = \frac{24 \cdot 3600 G_{sc}}{\pi} \left( 1 + 0.033 \cos \frac{360n}{365} \right) \left( \cos \phi \cos \delta \sin \omega + \frac{2\pi\omega_s}{360} \sin \phi \sin \delta \right),$$

where  $n$  is the number of the average day of the month,  $\delta$  the declination for the mean day of the month,  $G_{sc}$  the solar constant of  $G_{sc} = 1353 \text{W/m}^2$ ,  $\phi$  the latitude of  $\phi = -12.3$  for Rotuma, and  $\omega_s$  the sunset hour angle. Values for  $\delta$  and  $n$  are tabulated in [12], and  $\omega_s$  is calculated as

$$\cos \omega_s = -\tan \phi \tan \delta.$$

According to [12], the accuracy of this method strongly depends on the accuracy of climate and vegetation constants.

In order to validate the results, 20-day irradiation records were recorded specifically for this study on the island in 2006. The instrument was a Licor LI-200SA pyranometer, mounted horizontally on top of an existing 10m mast at the Ahau weather station (see Fig. 1). Data were recorded in 1min increments.

### 4.1.2 Results

The resulting monthly average daily solar irradiations for the horizontal surface are shown in Fig. 4. The values are average values for the past 6 years. Standard deviations are marked on the graph. As the graph shows, the seasonal variation in available solar energy is comparatively small.

The validation results were promising: For the period from April 5 to April 25, 2006, the Rotuma weather station records averaged 8.4 hours of sunshine per day. Using the equations and constants above, the calculated value for monthly average irradiation for this period is  $5221 \text{ Wh/m}^2$ . The measured value over the same period of time was  $5341 \text{ Wh/m}^2$ , i.e. 2% higher than the calculated value. A full validation of the data was beyond the scope of this study and the above single validation point does not allow to draw global conclusions. However, the close agreement in values for this point does increase confidence in the modeled values.

### 4.1.3 Summary of Solar Energy Potential

The solar resource on Rotuma has low seasonal variation with relatively high day to day availability. An average daily irradiation of xx makes it an attractive solar energy location. On a general note, the high relative humidity in Rotuma suggests that the percentage of direct radiation is low.

## 4.2 *Wind Energy Potential*

Rotuma's winds are determined by the Hadley cell; surface winds on Rotuma are thus dominated by southeast trades with relatively steady strong winds. However, during the Southern summer the steady trade winds are interrupted for varying periods due to the North-South shifts of the Intertropical Convergence Zone (ITCZ).

There are limited sources for reliable wind data for Pacific Islands. Most reported data are from local meteorological stations. Mean wind speeds as shown in the US wind atlas [13] or the Stanford wind mapping program [14] for Pacific Islands are low. However, [13] points out that the underlying data are at least questionable, because there is a trend that many weather stations in the area are not adequately exposed to the prevailing winds. Rotuma is a typical example. The single weather station is located on the lee side of the island. There are 3 large trees, up to 25m tall, within a 50m radius of the mast.

This study attempts to present a more realistic picture of the wind conditions on Rotuma. While six year data from the Rotuma station are used to establish longer term trends, actual wind performance is evaluated on the basis of simulated data. Wind data for a representative year were generated from meso-scale climate models, and wind maps created with the Wind Atlas Analysis and Application Program (WAsP). The modeling results were compared against short term observed data, recorded specifically for this study in 2006.

#### 4.2.1 Data and Methodology

The Ahau weather station on Rotuma has a cup anemometer mounted on a 10m mast. The station is located in S12deg30.01', E177deg2.806', as indicated in the map in Fig. 1. Wind speeds are read out manually in three hour intervals, and wind directions are estimated by the operator. For this study, the Fiji Meteorological Service released data from 2000 to 2006 with an average data recovery rate of 75%. According to [15], such a data recovery rate limits the data's usefulness for wind modeling. Instead, the data was used as an indication for longer term trends.

Short term (30 days) comparative wind data were recorded on the island in 2006. Locations of the three ten meter masts are shown on the map in Fig. 1: Ahau, Afgaha, and Motusa. All data were recorded with cup anemometers and ten minutely logging. Hourly wind data were produced as hourly averages of the ten minute data.

Wind data for modeling purposes were computer generated. The wind resource assessment combined two meteorological models to generate wind maps for Rotuma Island.

CSIRO's TAPM model (The Air Pollution Model), a three-dimensional numerical mesoscale atmospheric model was used to simulate the airflow over Rotuma Island and an area within about 12 km of the island area at a resolution of 800m for 2003. From the six year data of the Rotuma station, 2003 was chosen as a representative year of the longer term wind climatology for this area. The model generated hourly wind data at 1,225 points. At this resolution, the model is able to account for large-scale topographic and surface roughness features, but only provides an overall picture of the wind regime in the region. From the model, hourly wind data was obtained for a virtual mast site at a location about 6 km south of Rotuma Island. This point was chosen to be far enough away from the island due to its effects on the wind regimes but close enough to represent the wind climate for this area.

The hourly wind data derived from it were then used in the high resolution WASP model to generate detailed wind maps. The WASP model is able to account for high resolution elevation contour data (for Rotuma given at a 15 m resolution). Surface cover was assumed to be constant throughout the island at a roughness length of 0.4m. Calculations of mean wind speed predictions from the high resolution model were at 50m resolution.

While a full validation of the modeled results was not possible within the scope of this study, mean wind speeds from the map were compared against mean wind speeds of observed data from the three masts in Afgaha, Ahau, and Motusa for an identical period of time.

Wind turbine power outputs have been simulated for two sites on Rotuma: Motusa and Solkope Island. The simulation was carried out with Homer, based on 2003 hourly wind data. The data was linearly scaled to match annual mean wind speeds given in the wind map for these two locations. The mean wind speed for Solkope Island was reduced from

8m/s on the wind map to 7m/s in order to account for the models exaggeration in steep terrain, discussed below.

#### 4.2.2 Wind Survey Results

The 2003 mean wind speed at 25m above sea-level at the reference point 6 km South of Rotuma was determined to be 6m/s. This point represents the undisturbed open sea wind regime for Rotuma. Real wind speeds for sites on Rotuma depend on roughness, elevation, and geographical features. Annual mean wind speeds (2003) on and around Rotuma are shown in the wind map in Fig. 5.

The wind map shows a large variation of wind speeds across the island. This reflects Rotuma's rugged terrain with many steep volcanic cones, up to 220m tall. However, it is known that the WASP model tends to over-predict winds in steep areas [16].

The wind characteristics for Rotuma are described for Motusa, a sandy spit on the southern coast of the island (see map in Fig. 1). The description is based on the TAPM-generated one-hourly wind data file for the reference point 6 km south of Rotuma for the year of 2003, scaled to match the mean wind speed from the modeled wind map for this location.

The mean wind speed at Motusa (25m) is 5.6m/s, wind class 2. Monthly variation of wind speeds is shown in Fig. 6. Winds tend to be strong and steady for a few months in the Southern winter; this is the period for trade winds. Winds are significantly lower in summer. A typical summer is dominated by periods of inter-tropical convergence (minimal winds), and is regularly interrupted by periods of Southeast Trades.

Fig. 7 shows the wind speed distribution for Motusa. The best fit Weibull distribution has a shape parameter of  $k=2.3$ , and a weighed average speed of  $c=6.3\text{m/s}$ . The Weibull parameters were determined using the mean wind speed-standard deviation method described by Justus CG, Hargraves R et al. [17].

The average diurnal wind speed variation is not significant (Fig. 8). While in the Southern summer wind speeds show a slight peak around noon, the winter months with prevailing South East Trades show less diurnal variation.

Wind power outputs for Motusa and Solkope Island are shown in Table 1.

#### 4.2.3 Summary of Wind Potential

The analysis above supports Elliott's [13] hypothesis that the wind power potential on Pacific islands might be systematically underestimated. As elsewhere in the Pacific, the weather station on Rotuma is located in a poorly exposed position and does not reflect the real wind climatology in the region.

However, the analysis also shows some clear limitations: winds vary significantly throughout the seasons. Although capacity factors from 22% to 34% for the wind turbines suggest an acceptable range, Fig. 6 shows that most of the energy would be

produced in the months with prevailing South East trades. This poses a particular challenge for Rotuma where opportunities for energy storage are limited.

### **4.3 Copra Resource**

#### **4.3.1 Description of Existing Data**

Coconut oil has an important traditional standing on Rotuma. The coconut resource potential on Rotuma has been described in the [18] report. According to a recent report for the Coconut Industry Development Authority [19], 59% or 2615ha of the Rotuma's total land area of 4400ha was under coconut. All coconut trees are reported to be of productive age. Most present trees were planted in 1970, with the majority of trees of the Rotuma Tall variety. According to [18], sources on Rotuma suggest a maximum annual production of between 4.4 to 4.8 tons of dried copra (10% moisture content) per ha. Current production averages only 0.3 tons of copra per ha, i.e. 7% of the theoretical maximum. This low value has several reasons. Only part of the coconut resource is actually collected and processed, while a large portion remains under the trees to rot. The development of copra production over the last century is shown in Fig. 9. The most recent decline in production is largely attributed to the collapse of the Rotuma cooperative system in 1993/94 (BURGEAP 2006). According to Rensel (1993), previous fluctuations have a variety of explanations: The production increase in the 1940's is attributed to the introduction of motorized vehicles, but was finally limited by the lack of drying and storage facilities. Copra price declines tended to cause production declines. In particular, the 1939, 1948, and 1972 hurricanes incurred sharp drops in production for the following one or two years, respectively. CIDA (2004) estimates that the total copra production on Rotuma can be raised to 1500t/a with the existing trees only, or up to roughly 12,000t/a after extensive new planting. All estimates assume that the current portion of land under coconut is the maximum land area available for planting, other areas being either inaccessible, unsuitable, or used for other purposes. Using an average oil yield of 60% of dried copra, and a gross energy content of 34MJ/kg of coconut oil, the total energy value would be in the range of 51TJ/annum for the low estimate to 408TJ/annum for the high estimate.

#### **4.3.2 Summary of Copra Resource**

Copra is a viable resource on Rotuma. No additional planting would be required to replace the today's diesel generator consumption with coconut oil. Assuming a resource conversion efficiency of 25% from coconut oil to electricity, xx% of Rotuma's present production would suffice to meet present needs.

The long term production record suggests relatively high reliability of the resource.

## **5 Discussion**

While the affordability of energy in the light of rising diesel prices are one of the biggest factors involved, it is all-the-more important to make good use of a valuable resource. Even if no large scale renewable energy project could be realized on Rotuma it would be

advisable that faulty installations of diesel generators including faulty connections and unsuitable generators be replaced. Generator systems need to be connected by professional staff. Three phase generators should be replaced by single phase units, due to load balancing problems.

On Rotuma, low electricity users subsidize high users. Meters need to be installed and electricity charged on the basis of kWh readings.

Rotumans are accustomed to adapting appliance use to energy availability. The biggest problem is affordability; bankruptcy being a common cause for forced abolition of energy supply. The author strongly argues that energy affordability take the place of a perceived energy demand as a primary design criteria for sizing any alternative energy system.

The above analysis of energy options for Rotuma indicates that all three alternative energy source options, solar, wind, and copra are energetically able to supply Rotuma's present electricity needs. This section outlines opportunities and challenges to harnessing either form of energy.

On a general note, there are two options to proceed with energy development on the island: a continuation of the distributed generation scheme with mini grids on village level, or a central grid. While a central grid may appear the obvious solution for Rotuma, the very low level of energy consumption and the high costs of an island wide transmission system may suggest continued use of distributed, unconnected generation. [18] estimated the cost for a central 11kV grid to be in excess of US\$1m. This is a high price tag considering the low level of consumption and the small number of households.

The solar resource on Rotuma was shown to be relatively reliable with low seasonal variation. Generally, the high humidity on Rotuma suggests a relatively low ratio of direct to total irradiation, and confounds the use of any form of concentrating systems. Solar photovoltaics are thus the best candidate technology for solar electricity generation on Rotuma. Personal observations showed that the few existing solar installations on Rotuma were working well as long as **no inverters** were involved. All larger installations with inverters had already failed or were reported to be problematic.

The wind map in Fig. 5 conveys a positive picture of wind availability on Rotuma. However, there are limitations:

It is unlikely that turbines in excess of, say, 100kW capacity could be transported to and installed on Rotuma without mayor upgrades of the existing port and road infrastructure.

Especially for small turbines long transmission lines and dedicated access routes are often not feasible. Additionally, the exposed sites in Rotuma's interior are characterized by very steep volcanic rocks and bluffs overgrown in thick rain forest. If the terrain could be negotiated there could be further difficulties due to high wind shear in steep terrain.

Therefore, the most promising wind power sites on Rotuma would be close to the coast with south-east exposure and in only moderately-sloped terrain.

In the analysis, turbine power outputs were simulated for two illustrative locations. A location such as Motusa is technically preferable due to proximity to the village as well as ease of access and lack of wind shear problems. Solkope Island shows higher wind speeds, however, the steep volcanic cliffs would likely cause problems with wind shear on larger turbines while the location might be too far from the village to make a small turbine economical.

The high seasonal variability of wind poses a particular challenge: since energy storage on Rotuma is difficult and a large seasonal storage system would be prohibitively expensive, a hybrid wind-diesel system might be a cost effective way of utilizing the wind resource when available.

As documented above, copra is a well established and abundant resource on Rotuma, and could be considered very reliable. There are, however, two limitations to effectively using coconut oil as generator fuel: diesel generators have limited tolerance of this fuel and fuel quality is an issue for any small scale fuel production. Consultations with experts at the South Pacific Geosciences Commission (SOPAC) suggest that the local production of biodiesel on small islands is off-limits, because of the high level technology and large methanol import requirements. As a rule of thumb, SOPAC suggests to double maintenance requirements for a diesel generator if ran on coconut oil. This adds a significant viability risk for Rotuma, where maintenance is already a very difficult issue due to its isolation.

## **6 Conclusions**

Rotuma could reduce its diesel fuel bill significantly if generators were correctly sized and properly installed.

On Rotuma, low electricity users subsidize high users, a problem that could be solved if meters were installed and used as basis for pricing.

In order to secure energy affordability, alternative energy systems should be designed to match the realistic economic situation on the island rather than perceived energy demands.

Rotuma has a very good solar energy potential, with relatively low seasonal variation. The technology is limited to solar photovoltaics and is most promising for very small systems without inverters.

Wind data show that wind power is an option, however seasonal availability varies widely and storage on the island is difficult. In light of high seasonal variability, wind might still be an attractive option if used complementarily, for example in a diesel wind hybrid system. At the present infrastructure and energy demand, wind turbines in excess of 100kW are most likely not feasible.

Copra has the advantage of using an indigenous biomass resource that has been commercially produced for almost a century. People are used to diesel generators. However, existing and new commercially available diesel generators are designed for fossil fuels, and operation with coconut oil **will** cause problems, and in the best case reduce the useful life of involved generators.

## **Acknowledgements**

This study relied on the contributions of many, particularly Mike Green and Andy Sturman of the Department of Geography, University of Canterbury for creating wind maps of Rotuma. People from SOPAC, particularly Rupeni Mario and Gerhard Zieroth contributed in many ways in facilitating the field work in the Pacific as well as with technical advice and years of expertise in small power systems on Pacific Islands. On Rotuma, many people, particularly John Bennett and Fereti Fonmoa supported the field work. Acknowledged be the Council of Chiefs of Rotuma for welcoming and supporting the study.

The Pacific Island Development Trust contributed financial means to the field study, and the Fiji Meteorological Service and CSIRO generously provided meteorological data. Alan Howard and Jan Rensel, both of the University of Hawaii, gave anthropological advice and generously contributed their own experiences from their numerous studies on Rotuma.



## References

1. Jafar, M., *Renewable energy in the South Pacific - options and constraints*. Renewable Energy, 2000. **19**(2000): p. 305-309.
2. Matakiviti, A. and T. Pham, *Review of the 1993 Fiji Government rural electrification policy*. 2003, SOPAC: Suva, Fiji.
3. World Bank, *Pacific Regional Energy Assessment*, in *Pacific Island Series*. 1992, UNPEDP, World Bank: Suva, Fiji.
4. Clarke, W.C. and R.R. Thaman, *Agroforestry in the Pacific Islands: Systems for Sustainability*. 1993, Tokyo: United Nations University Press.
5. Woodhall, D., *Geology of Rotuma*. 1987, Suva, Fiji: Mineral Resources Department, Ministry of Lands, Energy & Mineral Resources.
6. Fiji Bureau of Statistics, *Census Report*. 1996, Government Press: Suva, Fiji.
7. Rensel, J., *Migrant involvement in the Economy of Rotuma*. Pacific Viewpoint, 1993. **34**: p. 215-240.
8. Turner, W.C., *Energy management handbook*. 4th ed. 2001, Lilburn, GA New York: Fairmont Press ; Distributed by Marcel Dekker. xvi, 773 p.
9. Fink, A., *How to conduct surveys*. 3rd. edition ed. 2006, Thousand Oak, CA: Sage Publications Inc.
10. Hamm, A., *Methodology and Modelling Approach for Strategic Sustainability Analysis of Complex Energy-Environment Systems*. 2007, University of Canterbury: Christchurch, New Zealand.
11. Page, J.K. *The estimation of monthly mean values of daily total short-wave radiatin on vertical and inclined surfaces from sunshine records for latitudes 40degN-40degS*. in *UN conference on new sources of energy*. 1964.
12. Beckman, W. and J. Duffie, *Solar Engineering of Thermal Processes*. 1980, New York: Wiley-Interscience.
13. Elliott, D.L., et al., *Wind Energy Resource Atlas of the United States*. 1986, Golden, CO, USA: Solar Technical Information Program.
14. Archer, C.L. and M.Z. Jacobson. *Evaluation of Global Wind Power and Interconnected Wind Farms*. in *American Geophysical Union, Fall Meeting 2005*. 2005: American Geophysical Union.
15. AWS-Scientific, *Wind Resource Assessment Handbook*. 1997, Albany, NY: NREL.
16. Bowen, A.J. and N.G. Mortensen. *Exploring the limits of WAsP: the Wind Atlas Analysis and Application Program*. in *European Union Wind Energy Conference and Exhibition*. 1996. Göteborg, Sweden.
17. Justus CG, et al., *Methods for estimating wind speed frequency distributions*. Journal of Applied Meteorology, 1977. **17**(3): p. 350-353.
18. BURGEAP, *Pacific Subregional: Renewable Energy and Energy Efficiency Programme (REEP), Volume I: Program Activities*. 2006, Report for the Asian Development Bank: Paris, France.
19. CIDA, *Feasibility study on setting up of a coconut wood mill in Savusavu, Vanua Levu, Fiji*. 2004, CIDA: Suva, Fiji

## Figure Captions

Fig. 1. Map of Rotuma Island. The map shows the seven districts and main villages. Also marked are wind monitoring sites.

Fig. 2. Appliance penetration. The chart shows survey results of 2006 field survey, conducted as part of this study.

Fig. 3. Load curve for typical village on Rotuma. Electricity is typically available for four hours per day, after sunset.

Fig. 4. Monthly average daily solar irradiation on Rotuma with standard deviations. The curve is based on six years of sunshine-hour data recorded by the Fiji Meteorological Service.

Fig.5. Wind map of Rotuma Island. The map shows annual mean wind speeds in m/s at a mast height of 25m. The map was created with WASP, and is based on annual data for a representative year, which was simulated with TAPM.

Fig.6. Monthly mean wind speeds on Rotuma. The curve is based on (incomplete) data by the Fiji Meteorological Service for the years 2000 through 2006.

Fig.7. Weibull distribution for Motusa. The curve is based on scaled TAPM generated wind data for 2003.

Fig.8. Diurnal variation in wind speeds for Motusa.

Fig.9. Copra production in tons per year. The data for this chart is taken from (Rensel 1993), and (BURGEAP 2006).

## Tables

Table 1  
Modelled wind power production for two locations on Rotuma.

	Motusa Spit		Solkope Island	
	Bergey Excel- R, 8kW <sub>rated</sub>	Fuhrländer 100, 125kW <sub>rated</sub>	Bergey Excel- R, 8kW <sub>rated</sub>	Fuhrländer 100, 125kW <sub>rated</sub>
Mean wind speed	5.6m/s	5.6m/s	7.0m/s	7.0m/s
Capacity Factor	21%	22%	35%	36%
Annual Energy	15MWh	239MWh	25MWh	394MWh

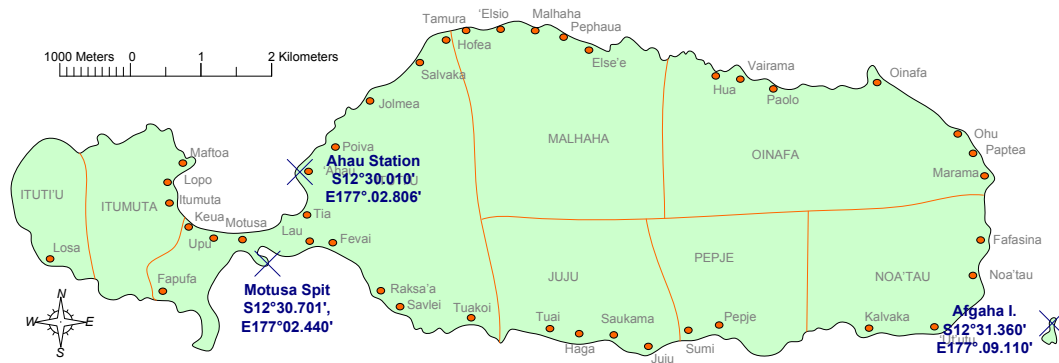

Fig. 1.

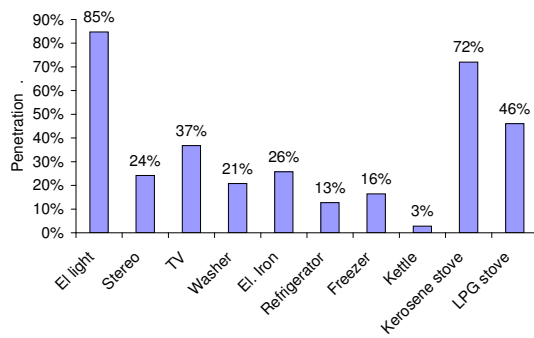

Fig. 2.

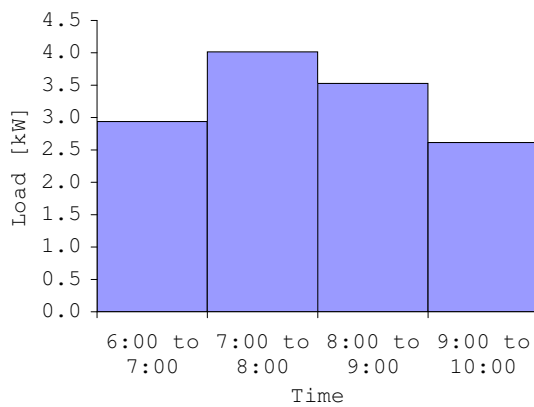

Fig. 3.

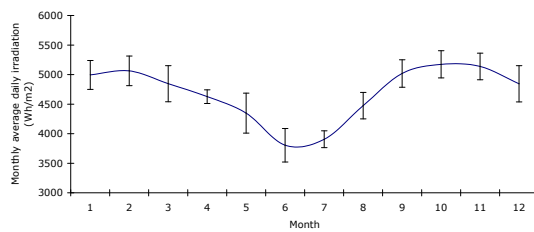

Fig. 4.

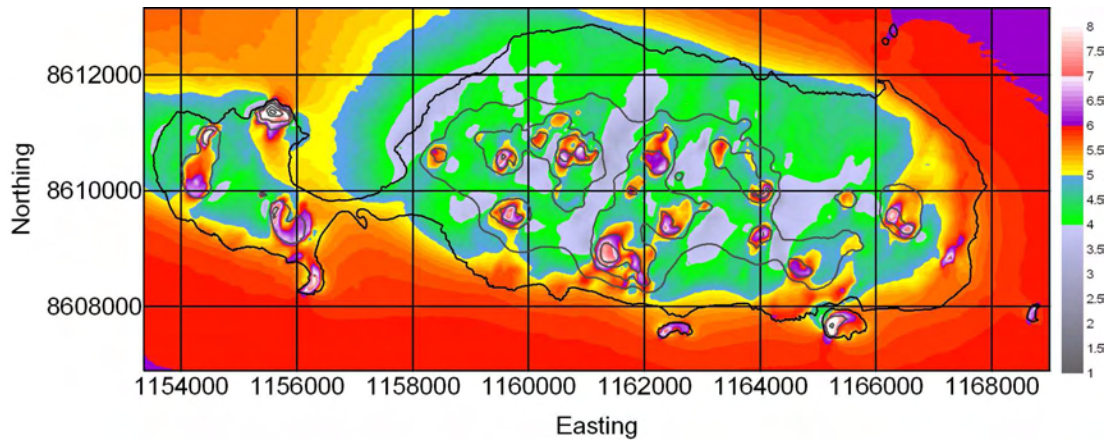

Fig. 5.

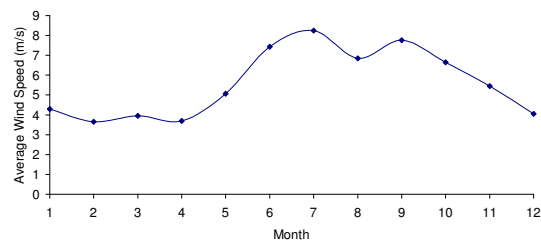

Fig. 6.

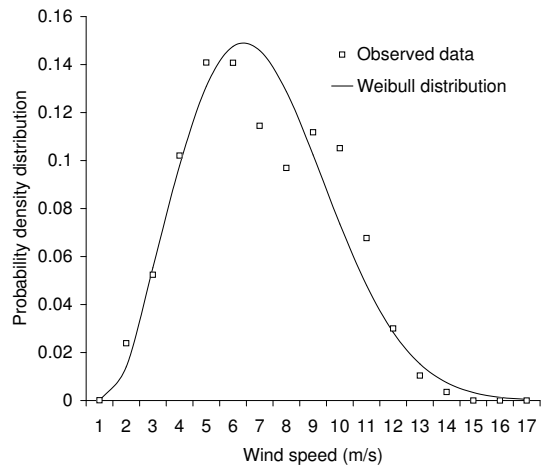

Fig. 7.

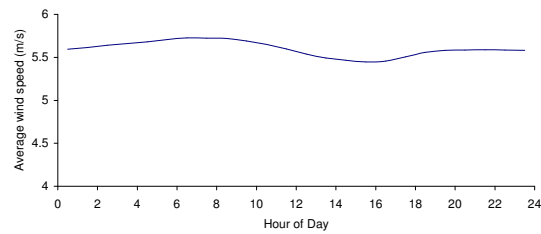

Fig. 8.

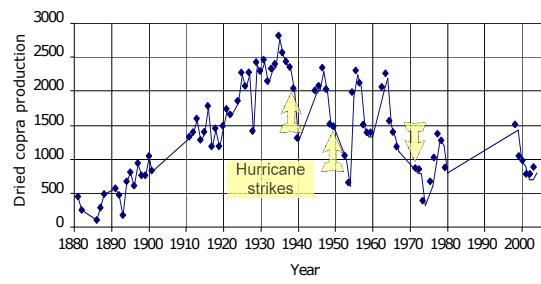

Fig. 9.

## **Appendix E – Peer Reviewed Papers**

*I. Submission draft: Energy Resource Paper*

*II. ICSES Conference Paper, accepted in 2007*

Authors: Andy Hamm, B.Sc., M.Sc., Dr. Susan Krumdieck, Dr. Mark Jermy

Presenter: Andy Hamm

Advanced Materials and Energy Systems Laboratory, Department of Mechanical Engineering  
University of Canterbury, Private Bag 4800, Christchurch, New Zealand  
Telephone: +64 3 364.2987 ext 7243  
E-Mails; ahh35@student.canterbury.ac.nz

## **Title**

Strategic Analysis of Continuity for Complex Energy and Environment Systems for Developing Regions

## **Abstract**

It is possible that in the near future, energy engineering will be called upon to help society adapt to permanently constrained fuel supplies, constrained green house gas emissions, and electricity supply systems running with minimal capacity margins. The goal of this research is to develop an analytical method for adaptive energy systems engineering within the context of resource constraints. The method involves assessing available energy resources, environmental and social issues, and economic activities. A spectrum of development options is identified for a given region and a *Reference Energy Demand* is calculated for each representative level. A spectrum of conceptual *Reference Energy System Models* is generated for each development level with a range of renewable energy penetration. The outcome is a matrix of energy system investment and resource utilization for the range of energy service level defined by the development level. These models are then used for comparative risk assessment. The result is an easily understood visual based investment and risk assessment for both development and adaptation to constrained resource availability. The above approach is being applied to a relatively simple case study on Rotuma, an isolated Pacific Island society. The case study results will show a clear development space for Rotuma where needs and services are in balance with investment, local resource availability and environmental constraints.

## **1 Introduction**

Most countries heavily rely on petroleum products as primary source of energy. However, global conventional oil production is expected to peak and then go into irreversible decline within the next two or three decades (Deffeyes, 2001), (Campbell, 2003), (Goodstein, 2004). Unless countries systematically prepare for declining oil supplies well ahead of time, there will be energy shortages of unprecedented scale (Hirsch, Bezdek, & Wendling, 2005). Energy shortages pose a severe risk to the continuity of society systems, herein referred to as *anthropogenic continuity*. But apart from imminent resource problems, energy extraction, conversion and use can also cause environmental problems; this poses an additional risk to anthropogenic continuity. These two risks are not well understood and are not or not adequately addressed in regional energy planning. Managing these risks is a daunting task because of the complexity of the problem and the uncertainties involved.



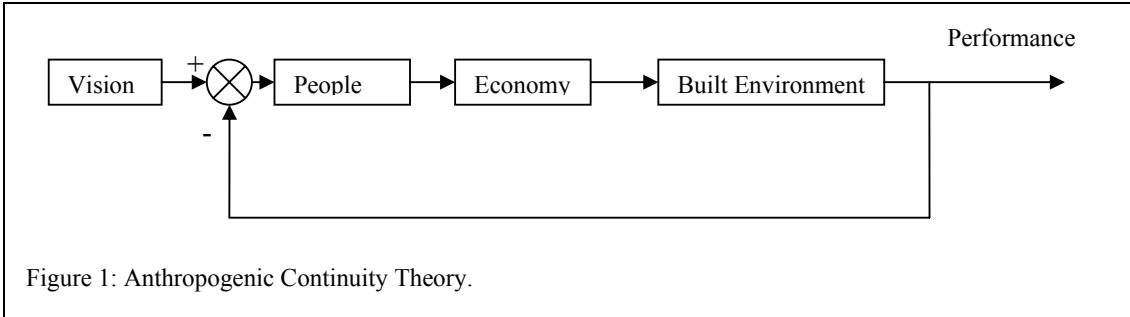

## 2 Materials and Methods

### 2.1 Introduction to the method

A theory has been proposed according to which people’s cumulative behavior, and this particularly with regards to their energy consumption in a given region, is primarily a function of the built environment. The built environment includes all infrastructures and all man-made entities. Figure 1 depicts the basic functionality of activities in any society as a controls diagram. The diagram is useful for understanding fundamental principles and limitations for day-to-day-life decision making on all levels. Generally, decisions are made on the basis of a vision, or of any concrete objective. In control engineering terminology, the vision represents the reference input. The controller is human. Any activity is enacted through economies in a wider sense. The activity is enacted within, and thus limited by the built environment. It is important to note that any particular objective can be accomplished in various ways. The role of the economy is rationality, the desire to accomplish an objective

with the optimum return of investment. The built environment determines the range of options. For example, Peter’s objective may be to procure dinner. The vision is Peter’s idea of where and how to get dinner. Peter’s preferences and economic considerations determine the course of action. The built environment dictates which options are, or are not available.

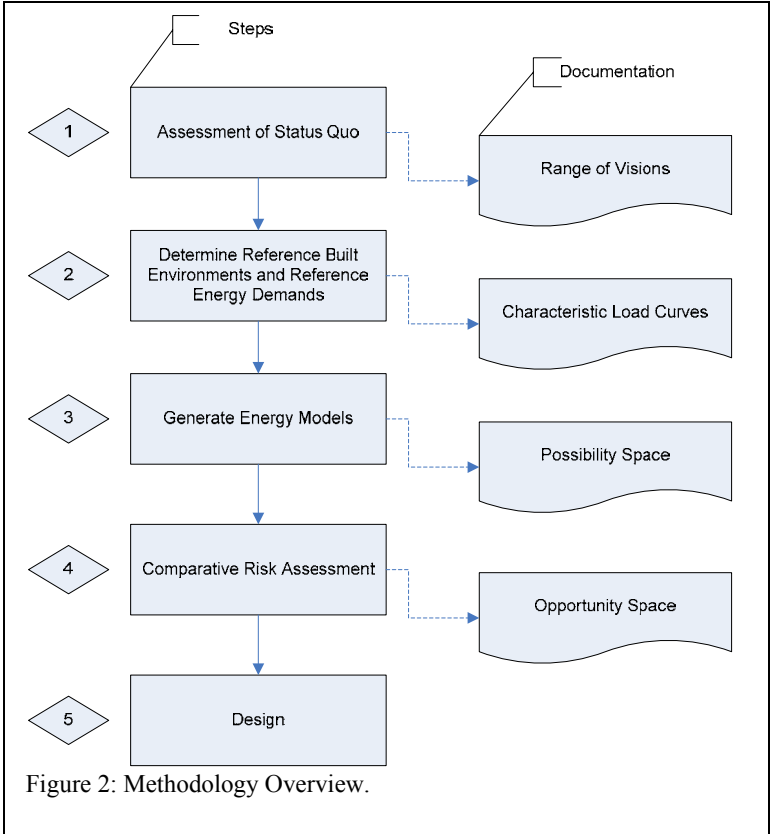

The role of the built environment is therefore that of an enabler for and a limiter of any activities. Most research on sustainability takes the present built environment for granted, assuming that fully developed Western

style built environments are both, irrevocable and most desirable. The herein presented method presumes that generally, a range of built environment levels can be equally desirable, and therefore a range of built environment levels is investigated. Thereby widening the scope of analysis opens the door for new solutions that have not previously been conceived.

## 2.2 General Description of the Method

An overview of the proposed method is given in Figure 2. The first step is the assessment of the status quo of the regional energy-environment-system. Produced data include energy flows, the economic situation, and people’s subjective development objectives, herein referred to as their *development visions*.

An every identified development vision is, in step 2, associated with a reference built environment which characterizes the particular development vision. And in turn, each type built environment requires a typical energy demand. Step 3 describes the development of a range of technically possible energy systems with different energy sources to supply the variety of energy demands. Combining a number of conceivable development levels with different

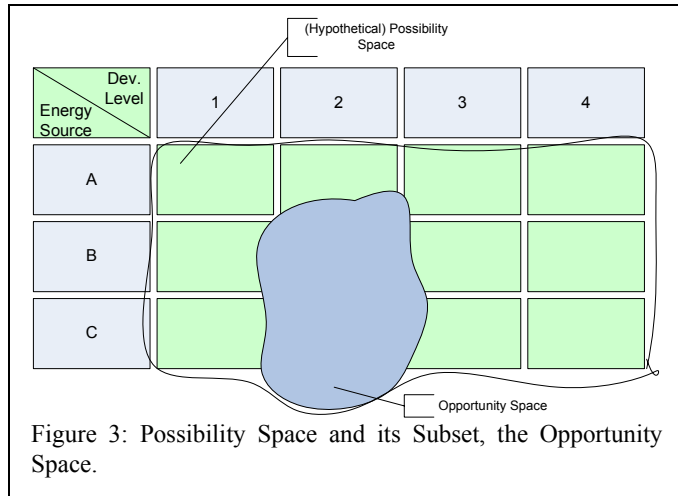

Figure 3: Possibility Space and its Subset, the Opportunity Space.

types energy resources results in a matrix of options, describing the *possibility space* (Figure 3). Comparative Risk Analysis follows in step 4, to evaluate inherent risks to the society. Considered risks are given rise to by two factors: environmental damage and service supply reliability. The above four steps generate as an outcome an opportunity space; that is a set of actually feasible regional energy systems as a subset of the possibility space, which is the range of the many technically feasible regional energy systems. Step 5 brings about the design of the actual regional energy system, founded on the opportunity space.

Having adumbrated the method above, the single steps are detailed in the subsequent sections.

## 2.3 Assessment of Status Quo

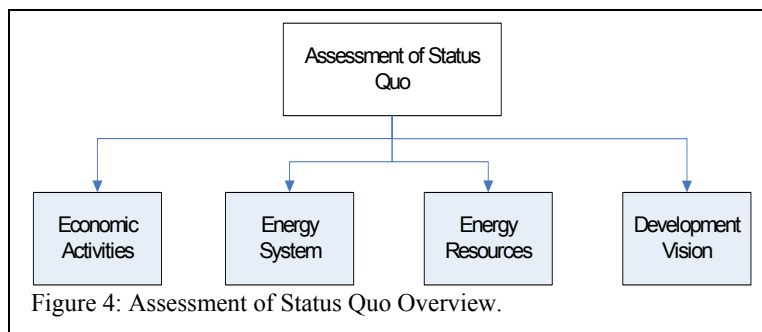

Figure 4: Assessment of Status Quo Overview.

Figure 4 shows the four different components of data collection required for subsequent analysis. Three of these components are part of standard regional energy planning procedure, and special only in detail and focus of the data collection.

**Economic activities** are assessed by how people spend their time, and also how much time is dedicated to economic activities. Essential outcomes are activity profiles and income distributions.

The **energy system** in place is analyzed on the supply side as well as on the demand side. Next to the main focus on surveying electricity, all other forms of energy use warrant a degree of attention; this is essential for an overall understanding of energy services and flows in the region. On the supply side, data is collected on the system layout, system condition, and system operation. Demand side analysis is done by means of an assessment of the energy services supplied, and the use and importance of these services to the people. Outcomes include appliance penetration data, energy expenditures, energy use distributions, and energy flow charts.

All significant local **energy resources** are assessed in terms of available quantities and accessibility. The data for all possible energy resources is plugged into subsequent energy models.

A novel part of an otherwise fairly standard ‘status quo assessment’ is a survey of **development visions**. This part adds a new dimension to traditional energy planning procedures. The rationale is twofold: people should have a say about where they would like to be in the future, but it is also recognized that finding feasible energy systems might require a larger range of options. A survey of development visions should identify a spectrum of visions of what different people would like their place to look like and be like in the future. The survey should pinpoint three or four representative visions, here referred to as development levels. These representative development levels are, in the next step, translated into characteristic build environments.

## 2.4 Determine Reference Built Environments and Energy Demands

A level of energy consumption is one of the decisive factors that characterize the level of development of a society. A level of development is unveiled by a particular lifestyle, and a particular lifestyle does occur because it is supported by the infrastructure, or in a wider sense, the built environment. This step of the method describes the transformation of people’s visions to something tangible, something that can be analyzed with engineering methods.

It is assumed that the electricity aspect of a built environment is a function of the development level<sup>1</sup> and the local climate. If possible, appliance use profiles are created from empirical data; that is appliance use profiles from regions with similar climates and the target development level. Otherwise it is to be estimated. Appliance use profiles are used to model an energy demand in the form of an electricity load curve. Figure 4 shows the process as described. There is a built-in loop, which means that the process is to be repeated for each one of the identified development levels.

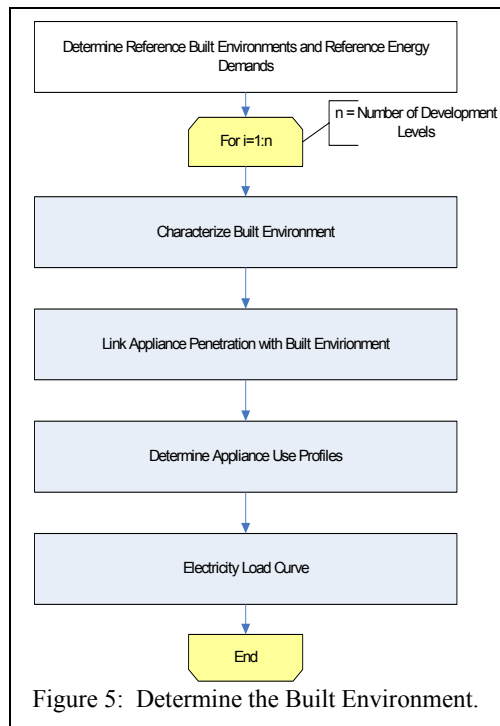

Figure 5: Determine the Built Environment.

<sup>1</sup> I have to define development level somewhere: it can be anything, really, but in the case of developing countries it is probably the degree of Westernization.

## 2.5 Energy Models

Once reference load curves have been determined for each of the identified development levels, energy models are developed with different energy supply options. What the energy supply options are is determined by the available energy resources. Only commercially proven technologies are herein considered. Combining m development options with n energy resource options results in a total number of n\*m basic energy system options. All n\*m option models are developed using standard energy modeling software. System sizing and requirements, investment, life cycle costs, and cost of energy are computed separately for each option.

## 2.6 Comparative Risk Assessment

Risk assessments always begin with setting out the context of the risk management problem at hand. In this case, the overall strategic goal is anthropogenic continuity. The unwanted opponent of anthropogenic continuity is *collapse* of a society. A tangible concept explaining the collapse of previous societies has been published by (Diamond, 2005). According to Diamond, there are five fundamental factors which are essential to the study of collapse: 1) environmental damage, 2) climate change, 3) hostile neighbors, 4) friendly trade partners, and 5) society's response to environmental problems. Two of these factors, 'climate change', and 'hostile neighbors' are beyond the scope of this engineering analysis. Although engineering solutions may contribute to climate change, it needs be appreciated that climate change policies within one region cannot do anything to avert climate change in this particular region. Local engineering does, however, significantly affect possible 'environmental damage' in a region. Petroleum supplies and shortages to and in a region are covered under the 'friendly trade partners' factor. (Diamond, 2005) found that his fifth factor, 'society's response to environmental damage' was the single one factor which played a role in the failure of all societies that failed. In an effort to learn from others' mistakes, this research is dedicated to contribute to improving our own 'society's response to environmental problems.

Two out of the five factors Diamond introduced are suitable and appropriate for risk analysis to anthropogenic continuity in the regional energy planning context: 1) Resource availability to supply candidate energy systems ('friendly trade partners') and 2) Environmental problems.

### The Risk of Energy Shortages

Figure 6 overviews the evaluation of the risk to us caused by declining conventional oil production. This probability for this risk is determined on the basis of petroleum production forecasts. This is difficult to analyze, because of the inherent uncertainties in assessing petroleum availability. At the current standard of knowledge in petroleum geology, it can be

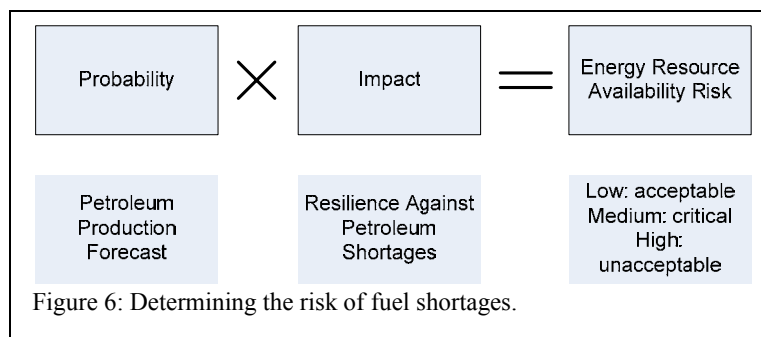

taken for a fact that global petroleum production will peak. Due to unreliable reserve estimates and production data it is, however, unclear when the peak will occur. Also unclear is, what the supply situation in a specific country will be, relative to

global fuel availability. For member countries of the International Energy Agency (IEA), the

IEA will ration energy supplies in a shortage situation, for non-members the supply situation is less predictable.

We propose to keep analysis independent of the exact year of peak oil occurrence. In order to facilitate meaningful analysis, it is assumed that the development options derived in the previous sections are fully developed and fully functional at the year of peak oil, whatever the exact year may be. At the lack of more detailed data, it is assumed that fuel supply to a specific country will follow the same trend as global fuel supply. Post-peak global fuel supply is here modeled according to (Hirsch, Bezdek, & Wendling, 2005). Hirsch modeled three different scenarios of mitigation to the petroleum supply risk, assuming 20 years, 10 years, and 0 years of preparation time for strategic risk management program. It is here assumed that there will be no preparation time, and that mitigation of the petroleum shortage problem will commence only after peak oil happens. This is a valid assumption in case peak oil happens soon, i.e. in less than ten years from now. (Dantas, Krumdieck, & Page, 2006) proposed two methods for calculating the probability of peak oil occurrence in any given year. A conservative

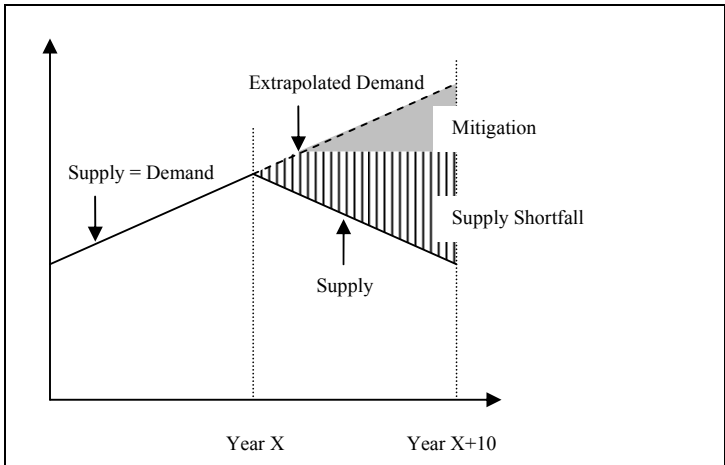

Figure 7: Modeling Fuel Supplies, after (Hirsch, Bezdek, & Wendling, 2005)

approach yielded a likelihood for peak oil occurrence before 10 years from now, i.e. before 2016, of 40%. But what is believed to be a more realistic approach suggests that the likelihood of oil peaking within 10 years from now is closer to 80%. The global energy supply scenario after (Hirsch, Bezdek, & Wendling, 2005) is shown in Figure 7. Year X refers to the unknown years of peak oil. The supply for the 20 years time span considered is approximated by an annual 2% rise in petroleum production up to year X, and a production decline of an equal 2% per annum thereafter. The mitigation wedge in the figure results from a mix of energy savings through efficiency, and substitute fuels to replace petroleum products.

approach yielded a likelihood for peak oil occurrence before 10 years from now, i.e. before 2016, of 40%. But what is believed to be a more realistic approach suggests that the likelihood of oil peaking within 10 years from now is closer to 80%. The global energy supply scenario after (Hirsch, Bezdek, & Wendling, 2005) is shown in Figure 7. Year X refers to the unknown years of peak oil. The supply for the 20 years time span considered is approximated by an annual 2% rise in petroleum production up to year X, and a production decline of an equal 2% per annum thereafter. The mitigation wedge in the figure results from a mix of energy savings through efficiency, and substitute fuels to replace petroleum products.

### Environmental Damage

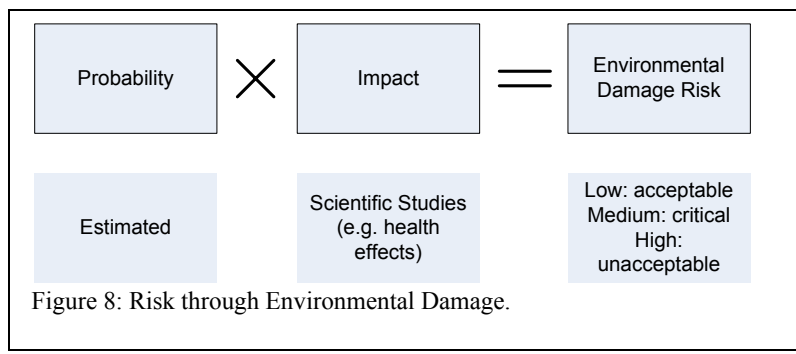

Figure 8: Risk through Environmental Damage.

Risk analysis for environmental damage is assessed as indicated in Figure 8. Impacts are on the basis of direct as well as indirect damage. Direct damage shall be referred to as damage or degradation to be nominally expected during the lifetime of an

energy plant. Indirect damage shall be damage caused not by the energy system but by

various other consequences from a strategic development level. The issues involved in assessing the risk to environmental damage are highly complex. In order to preserve transparency and comparability, the analysis is, in this research, held at relatively high level. Where reasonable, risks are assessed quantitatively. Otherwise qualitative analysis is used.

### 3 Case Study

#### 3.1 General and results

The method above is being applied to Rotuma Island, a small Pacific Island within Fijian territory. Rotuma has been chosen for several reasons: with a land area of 40km<sup>2</sup> and a 2500 permanent population it is small and relatively easy to overview. The closest neighboring island is more than 500km away; Rotuma can therefore be analyzed as a closed system. Rotuma has 32 main villages located around the perimeter of the island. The island is approximately 15km long and 4km wide. The climate is tropical with high rainfall and the soil is unusually fertile. Parts of the island are too rocky or too steep for cultivation; thus about 30% of the island is covered in native bush (Clarke & Thaman, 1993). Despite of relatively strong Western influence, most people are fully ingrained in their traditional way of live of subsistence farming. Traditional transportation by canoes has been replaced by bus, trucks and motorbikes on the main road around the perimeter of the island. The link to the closest neighbor, Fiji, is by a monthly boat service and almost weekly flights by small aircraft. The majority of people live in simple concrete structures with corrugated iron roofs (Fiji-Bureau-of-Statistics, 1996).

Field research has been conducted on the island in 2006; activities on the island included detailed energy supply system, energy needs, and energy resources surveys, as well as a survey of people's personal development objectives. Figure 9 gives an overview of appliance ownership on the island. The energy system is based on village level Diesel generation.

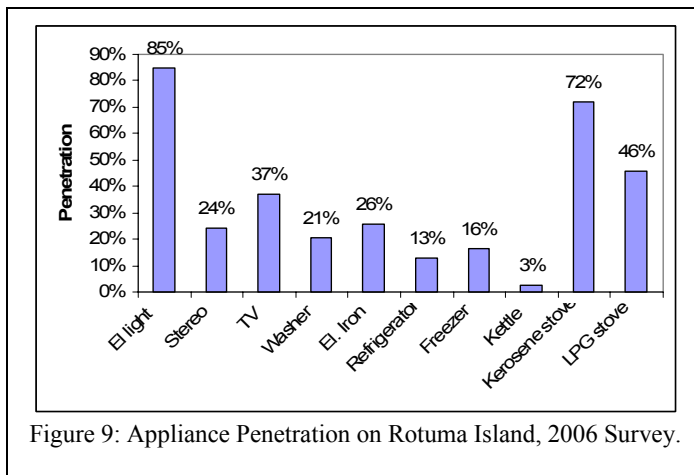

Figure 9: Appliance Penetration on Rotuma Island, 2006 Survey.

Electricity is typically available for about 4 hours every evening. The Diesel supply to the island is unreliable and expensive. Indigenous energy resources have been surveyed in some detail. Three options are technically possible: Coconut oil, wind, and solar power. Coconuts are the main export from the island. More than enough copra is available to replace the present Diesel demand with bio-diesel from coconut oil. Average daily

insolation varies from 3.5kWh/day in winter, to 4.5kWh/day in summer. Figure 10 gives an overview of the wind power potential. The wind map has been modeled using topographical data and wind data from global weather models as well as data recorded on the island. While annual mean wind speeds suggest that wind power might be feasible, the wind is relatively unreliable. Significant power winds are the Southeast trades. The trade winds can stop for several weeks during periods of intertropical convergence.



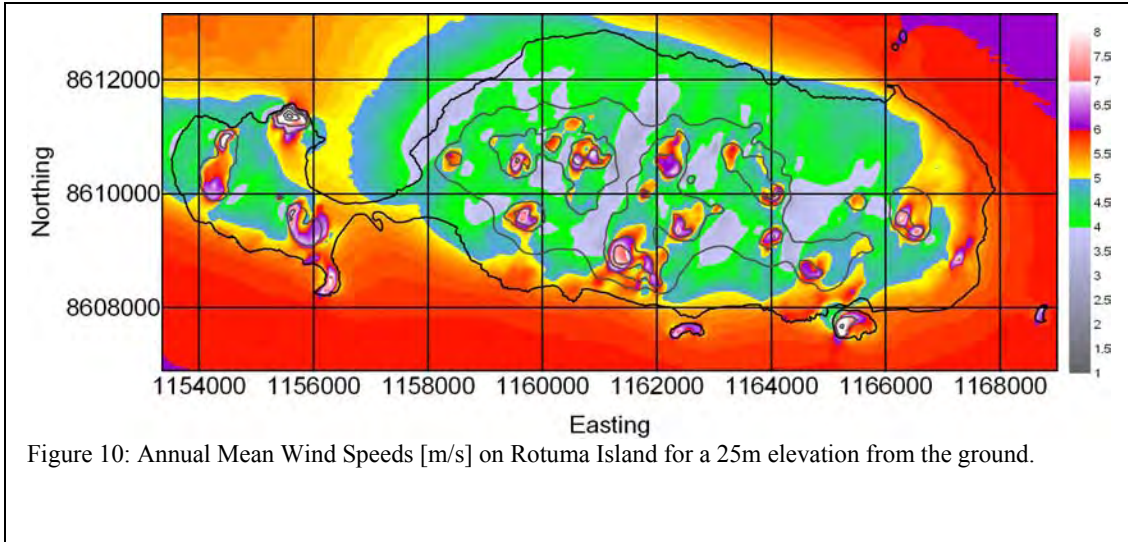

Figure 10: Annual Mean Wind Speeds [m/s] on Rotuma Island for a 25m elevation from the ground.

As mentioned above, apart from the more technical surveys above, an attempt was made at surveying the development objectives of the people in Rotuma. Individual preferences vary widely. Some people explained how the modernized way of life, e.g., especially paying the monthly electricity bills did actually make their lives harder; these people expressed their interest in reverting back to the traditional life without electricity and so forth. The other extreme were people who enjoy Western amenities, and would like to get as much of it as possible. But there were also people who were content with the present level of development, not wanting any change, or only very selected change. In order to cover the spectrum of differing objectives, people’s visions for the future were categorized into four levels: (1) Back to Traditional Life, (2) Some improvements, but no considerable change, (3) Moderate development, and (4) full development to a level comparable to Suva (this is the capital of Fiji).

### 3.2 Rotuma Potential

Following the method above, several energy models were created for different combinations of development levels with energy systems based on different resource inputs. The resource options are derived from the resource survey. The following energy supply options are considered: (1) Fossil fuel

Dev. Level Energy Source	Back to Traditional Life	No Considerable Change	Moderate Development	Full Development
Fossil Fuel	N/A	Village Diesel Generators	Central Diesel Generators	Central Diesel Generators
Copra Biodiesel	N/A	Village Diesel Generators	Central Diesel Generators	Central Diesel Generators
Solar PV	N/A	Village PV Plant, Battery Storage	Central PV Plant, Battery Storage	Central PV Plant, Battery Storage
Hybrid Solar PV & Fossil	N/A	Village Diesel - PV-Battery Plant	Central PV-Diesel-Battery Plant	Central Diesel-PV-Battery Plant
Wind	N/A	Village Wind Turbines & Battery Storage	Central Wind Plant & Pumped Storage	Central Wind Plant and Pumped Storage
Hybrid Wind & Fossil	N/A	Village Wind Plants & Diesel Generators	Central Wind Plant & Diesel Generators	Central Wind Plant & Diesel Generators

Figure 11: Rotuma Energy System Possibility Space.

(Diesel), (2) Copra (bio diesel), (3) Solar (PV), (4) Mix Solar&Fossil, (5) Wind, (6) Mix Wind&Fossil. Combining the four development options of the previous section with the six supply options above, results in a total of 24 energy system options; or in reality 18 options, because the ‘Back to Traditional Life’ option implies no electricity usage. The range of

options, which we refer to as possibility space, is shown in matrix form in Figure 11. Every element in the possibility space stands for an energy model. Each energy system is modeled using real data collected on the island. The modeling platform is Homer with auxiliary modeling in Matlab. The demand is modeled through load curves, one for each development level. The load curve for the 'No Considerable Change' option is based on real load curves recorded on the island. Load curves for the other development levels are modeled on the basis of hypothetical appliance penetration and use data. Modeling the energy systems has not yet been completed at the time of writing. Comparative risk assessment following the method described is in progress, but results are not yet available.

## **4 Discussion**

The work treated in this paper reflects an attempt to define sustainability in very tangible terms. Sustainability is treated in the light of two significant risks faced by all peoples around the world: The risk of resource supply shortages caused by the imminent peaking of conventional oil production and another risk given rise to by environmental problems. The term sustainability is used in very different ways by different researchers. In this research, sustainability is defined as Anthropogenic Continuity. Anthropogenic Continuity does not refer to a static state of a society. Anthropogenic systems are never static and are generally in a continuous process of change and adaptation. But it is also possible that this continuity of regional anthropogenic systems is, often painfully, interrupted by various forms of crises. It is therefore the utmost concern behind this research, to mitigate the risks to the Continuity of our Anthropogenic Systems. It is fully recognized that the mitigation of this risk is likely to involve much more than replacing fossil fuels with renewable energies; hence the approach to expand the scope of analysis to include various levels of development. The employment of risk analysis ultimately allows for articulate communication of analysis results. Risk is a language spoken throughout professional disciplines. Communication of the results leads the audience from the easily understood possibility space, through risk analysis, to the opportunity space. The opportunity space includes only those energy system options which inherently pose manageable levels of risk to the Continuity of the Regional Anthropogenic System.

## **5 Conclusions**

This paper presented a workable method to manage the new energy resource and environmental constraints facing our societies. This method has been tailored to suit developing countries, but the general approach is applicable to any society. The issues involved are complex, and this method is only one of many conceivable ways of addressing the risks to Anthropogenic Continuity. Much more work is required, and the authors hope that this paper encourages more research into risk management for the risks to Anthropogenic Continuity.



## References

- Campbell, C. J. (2003). Industry urged to watch for regular oil production peaks, depletion signals. *OGJ*.
- Clarke, W. C., & Thaman, R. R. (1993). *Agroforestry in the Pacific Islands: Systems for Sustainability*. Tokyo: United Nations University Press.
- Dantas, A., Krumdieck, S., & Page, S. (2006). *Energy Risk to Activity Systems as a Function of Urban Form*. Wellington, New Zealand: Land Transport New Zealand.
- Deffeyes, K. S. (2001). *Hubbert's peak : the impending world oil shortage*. Princeton, N.J.: Princeton University Press.
- Diamond, J. M. (2005). *Collapse : how societies choose to fail or succeed*. New York: Viking.
- Fiji-Bureau-of-Statistics. (1996). *Census Report*. Suva, Fiji.
- Goodstein, D. (2004). *Out of gas - the end of the age of oil*: W.W.Norton.
- Hirsch, R., L., Bezdek, R., & Wendling, R. (2005). *Peaking of World Oil Production: Impacts, Mitigation, & Risk Management*: U.S. Department of Energy, National Energy Technology Laboratory.